

# OWNER'S GUIDE & INSTALLATION INSTRUCTIONS

## Ultrasonic Speed Sensor with Valve and Temperature

Model CS4500-610

U.S. Patents 5,186,050; 6,426,918

11/02

17-263-01 rev. 01

**IMPORTANT:** Please read these instructions completely before proceeding with the installation. These instructions supersede any other instructions in your instrument manual if they differ.

Record the information found on the cable tag for future reference.

Part No. \_\_\_\_\_ Date \_\_\_\_\_ Frequency \_\_\_\_\_ kHz

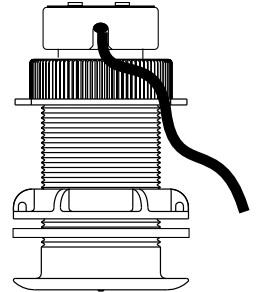
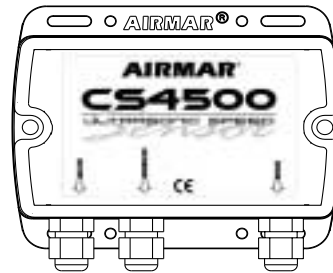

## How the Ultrasonic Speed Sensor Works

The speed sensor uses ultrasonic pulses to collect echoes from small particles in the water as they pass under two transducers embedded in the insert (see Figure 1). These transducers monitor the particles in their respective beams. As the boat travels through the water, both transducers "view" the same stream of particles. Because it takes time for particles to travel between the two transducers, the aft transducer detects the particles later than does the fore transducer. By measuring this time lapse, the instrument calculates the boat speed.

The ultrasonic speed sensor requires particles in the water to obtain echoes. If the boat is airborne even for a short time or in highly aerated water, the sensor will measure an incorrect speed.

**IMPORTANT:** The ultrasonic speed sensor must be in good contact with the water at all times for the sensor to function properly.

### CAUTION: NEVER USE SOLVENTS!

Cleaners, fuel, paint, sealants, and other products may contain strong solvents, such as acetone, which can attack many plastics greatly reducing their strength.

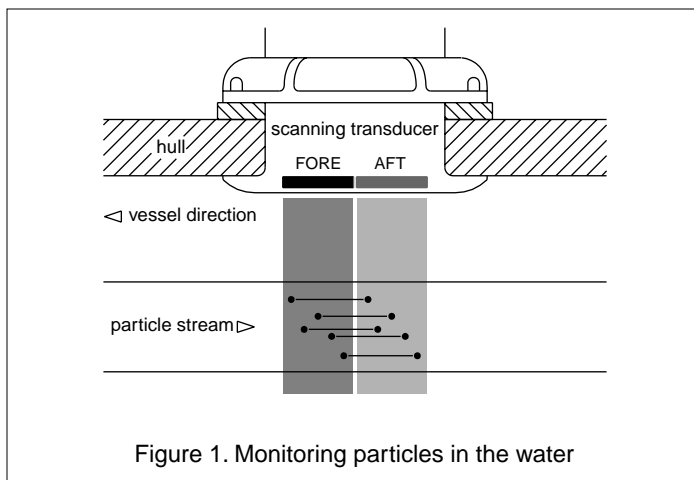

Figure 1. Monitoring particles in the water

## Applications

- Not recommended for boats designed to pull air under the hull.
- **Plastic** housing recommended for fiberglass or metal hulls only. *Never* install a plastic sensor in a wood hull since swelling of the wood may overstress the plastic causing a fracture.
- **Bronze** housing recommended for fiberglass or wood hulls only. *Never* install a bronze housing in a metal hull because electrolytic corrosion will occur.
- *Never* install a metal housing in a vessel with a positive ground system.
- Ultrasonic insert *must* be installed in a housing with a valve. **Raymarine ST-40**—The ultrasonic insert is too long for the existing housing. Install the new housing.

## Tools and Materials

- Water-based antifouling paint (**mandatory in salt water**)
- Safety goggles
- Dust mask
- Electric drill with 10mm or larger chuck capacity
- Drill bit 3mm or 1/8"
- Hole saw 51mm or 2"
- Sandpaper
- Mild household detergent or weak solvent (such as alcohol)
- File (installation in a metal hull)
- Marine sealant
- Additional washer [for aluminum hull less than 6mm (1/4") thick]
- Slip-joint pliers (installing a metal housing)
- Installation in a cored fiberglass hull (see page 3):
  - Hole saw for hull interior 60mm or 2-3/8"
  - Fiberglass cloth and resin
  - or Cylinder, wax, tape, and casting epoxy

## Antifouling Paint

Marine growth can accumulate rapidly on the ultrasonic sensor's surface reducing performance within weeks. Surfaces exposed to salt water *must* be coated with antifouling paint. Use **water-based** antifouling paint only. *Never* use ketone-based paint, since ketones can attack many plastics possibly damaging the sensor.

It is easiest to apply antifouling paint before installing the sensor, but allow drying time. Reapply paint every 6 months or at the beginning of each boating season. Paint the following surfaces (see Figure 2):

- Outside wall of the ultrasonic insert below lowest O-ring
- Active face of the ultrasonic insert
- Exterior lip of housing
- Bore of housing up 30mm (1-1/4")
- Blanking plug below lowest O-ring including exposed end

## Mounting Location

Turbulence-free water *must* flow under the ultrasonic sensor at all speeds. Choose an accessible spot with a minimum of 200mm (8") of headroom inside the vessel to allow for the height of the housing, tightening the nuts, and removing the insert.

- **Fin keel sailboats**—Mount the sensor on or close to the centerline and forward of the fin keel 150–300mm (1/2–1').
- **Full keel sailboats**—Locate the sensor amidships and away from the keel at the point of minimum deadrise.
- **Displacement hull powerboats**—Locate the sensor amidships near the centerline.
- **Planing hull powerboat**—Mount the sensor well aft to ensure it will be in contact with the water at high speeds.

**Caution:** Do not mount the sensor in an area of turbulence or bubbles: near water intake or discharge openings; behind strakes, fittings, or hull irregularities; or behind eroding paint (an indication of turbulence).

**Caution:** Never mount the sensor directly ahead of a depth transducer, since turbulence generated by the housing will adversely affect the depth transducer's performance, especially at high speeds.

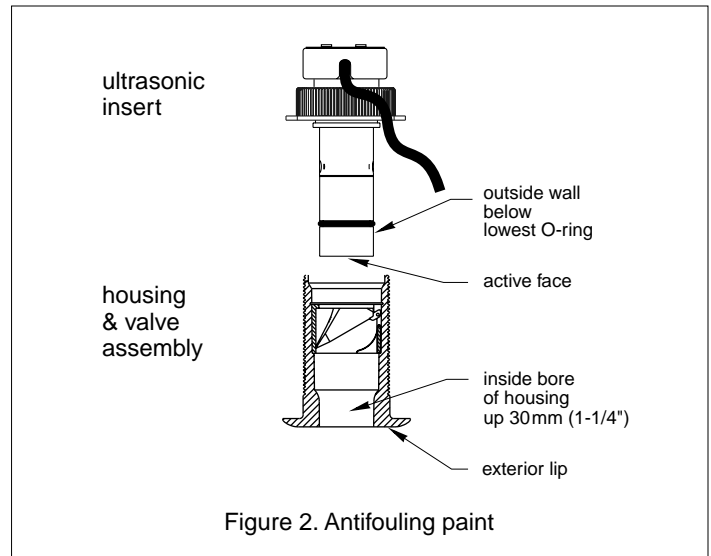

Figure 2. Antifouling paint

## Installation

**Cored fiberglass hull**—Follow separate instructions on page 3.

### Hole Drilling

**Warning:** Always wear safety goggles and a dust mask.

1. Drill a 3mm or 1/8" pilot hole from inside the hull. If there is a rib, strut, or other hull irregularity near the selected mounting location, drill from the outside.
  2. Using the 51 mm or 2" hole saw, cut the hole from outside the hull.
  3. Sand and clean the area around the hole, inside and outside, to ensure that the sealant will adhere properly to the hull. If there is any petroleum residue inside the hull, remove it with either mild household detergent or a weak solvent (alcohol) before sanding.
- Metal hull**—Remove all burrs with a file and sandpaper.

### Bedding

Apply a 2mm (1/16") thick layer of sealant around the lip of the housing that contacts the hull and up the sidewalls of the housing. The sealant *must* extend 6mm (1/4") higher than the combined thickness of the hull, washer(s), and hull nut (see Figure 3). This will ensure there is sealant in the threads to seal the hull and to hold the hull nut securely in place.

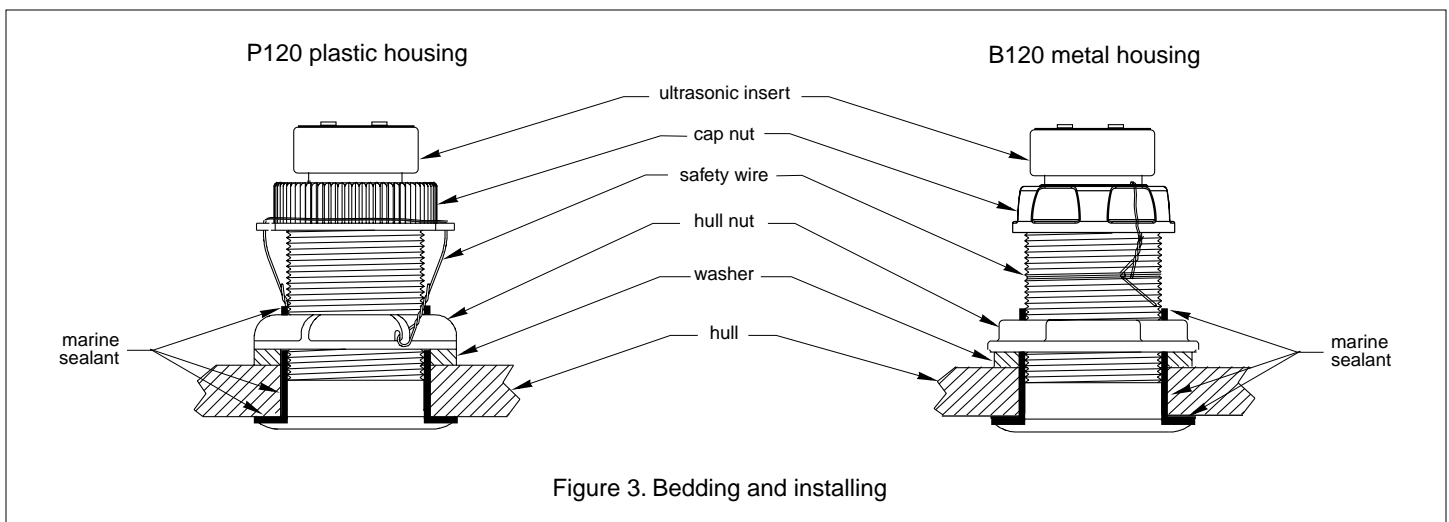

Figure 3. Bedding and installing

## Installing

**Caution:** *Never pull, carry, or hold the ultrasonic insert by the cable as this may sever internal connections.*

1. From outside the hull, push the housing into the mounting hole using a twisting motion to squeeze out excess sealant (see Figure 3). **Align the arrow on the lip of the housing pointing forward toward the bow.** If the sensor is not installed on the centerline, angle the housing slightly toward the centerline to align it with the water flow.
2. From inside the hull, slide the washer onto the housing.  
**Aluminum hull less than 6mm (1/4") thick**—Use an additional rubber, fiberglass, or plastic washer. *Never* use bronze since electrolytic corrosion will occur. *Never* use wood, since it will swell possibly fracturing the plastic housing.
3. Screw the hull nut in place *being sure* the notch on the upper rim of the housing and the corresponding arrow on the lip are still positioned forward toward the bow (see Figures 3 and 5). (If your plastic housing has wrenching flats, do not clamp tightly, possibly causing the housing to fracture.)  
**Plastic hull nut**—**Hand-tighten** only. *Do not* over-tighten.  
**Metal hull nut**—Tighten with slip-joint pliers.  
**Wood hull**—Allow the wood to swell before tightening the hull nut securely.
4. Remove any excess sealant on the outside of the hull to ensure smooth water flow over the ultrasonic insert.

**Warning: The O-rings must be intact and well lubricated to make a watertight seal.**

5. After the sealant cures, inspect the O-rings on the ultrasonic insert (replace if necessary) and lubricate them with the silicone lubricant supplied.

**Important:** *For the sensor to work properly, the bottom of the insert must be flush with the bottom of the housing.*

6. Slide the ultrasonic insert into the housing with the arrow on the top pointing forward toward the bow. Seat it into place with a pushing twisting motion until the key fits into the notch. The arrow on the tip of the insert, the notch in the housing, and the arrow on the lip will be aligned. *Be careful* not to rotate the housing and disturb the sealant. Screw the cap nut in place and **hand-tighten** only. *Do not* over-tighten (see Figure 3).

**Warning:** *Always attach the safety wire to prevent the insert from backing out in the unlikely event that the cap nut fails or is screwed on incorrectly.*

7. Attach the safety wire.

**Plastic housing**—Attach the safety wire to one eye in the hull nut. Lead the wire in a counterclockwise direction and thread it through one eye in the cap nut, along the side of the cap nut, through the second eye in the cap nut, and the second eye in the hull nut. Twist the wire securely to itself.

**Metal housing**—Wrap one end of the safety wire tightly around the housing and twist it together with the long end. Lead the wire straight up and through the eye in the cap nut. Loop the wire back down and twist it securely to itself.

8. To wire the ultrasonic sensor, follow the instructions, "Wiring" on page 5.

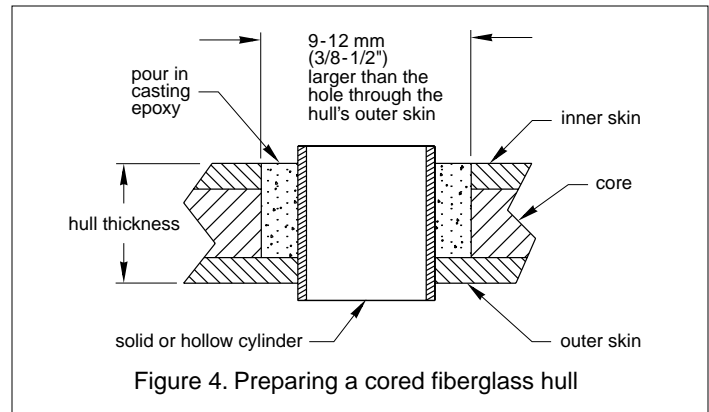

## Checking for Leaks

**Warning:** *Never install a thru-hull sensor and leave the boat in the water unchecked for several days.*

When the boat is placed in the water, **immediately** check around the thru-hull sensor for leaks. Note that very small leaks may not be readily observed. It is best not to leave the boat in the water for more than 3 hours before checking it again. If there is a small leak, there may be considerable bilge water accumulation after 24 hours. If a leak is observed, repeat "Bedding" and "Installing" **immediately**.

## Installation in a Cored Fiberglass Hull

The core (wood or foam) *must* be cut and sealed carefully. The core *must* be protected from water seepage and the hull *must* be reinforced to prevent it from crushing under the hull nut allowing the housing to become loose.

**Warning:** *Always wear safety goggles and a dust mask.*

1. Drill a 3mm or 1/8" pilot hole from inside the hull. If there is a rib, strut, or other hull irregularity near the selected mounting location, drill from the outside. (If the hole is drilled in the wrong location, drill a second hole in a better location. Apply masking tape to the outside of the hull over the incorrect hole and fill it with epoxy.)
2. Using the 51 mm or 2" hole saw, cut the hole from outside the hull through the *outer* skin only (see Figure 5).
3. From inside the hull, use the 60mm or 2-3/8" hole saw to cut through the *inner* skin and most of the core. The core material can be very soft. Apply only light pressure to the hole saw after cutting through the inner skin to avoid accidentally cutting the *outer* skin.
4. Remove the plug of core material so the *inside* of the outer skin and the inner core of the hull are fully exposed. Sand and clean the inner skin, core, and the outer skin around the hole.  
**Caution:** *Completely seal the hull to prevent water seepage into the core.*
5. If you are skilled with fiberglass, saturate a layer of fiberglass cloth with a suitable resin and lay it inside the hole to seal and strengthen the core. Add layers until the hole is the correct diameter.  
Alternatively, a hollow or solid cylinder of the correct diameter can be coated with wax and taped in place. Fill the gap between the cylinder and hull with casting epoxy. After the epoxy has set, remove the cylinder.
6. Sand and clean the area around the hole, inside and outside, to ensure that the sealant will adhere properly to the hull. If there is any petroleum residue inside the hull, remove it with either mild household detergent or a weak solvent (alcohol) before sanding.
7. Proceed with "Bedding" and "Installing" on page 2.

# Operation, Maintenance, and Repair

## How the Valve Works

The sensor incorporates a self-closing valve which minimizes the flow of water into the vessel when the ultrasonic insert is removed. The curved flap valve is activated by both a spring and water pressure. Water pushes the flap valve upward to block the opening, so there is no gush of water into the boat.

### **WARNING: THE VALVE IS NOT A WATERTIGHT SEAL!**

Always install the ultrasonic insert or the blanking plug secured with the safety wire for a watertight seal.

## Using the Blanking Plug

To protect the ultrasonic insert, use the blanking plug when:

- The boat will be kept in salt water for more than a week.
- The boat will be removed from the water.
- Aquatic growth build-up is suspected due to inaccurate readings from the instrument.

### **Warning: The O-rings must be intact and well lubricated to make a watertight seal.**

1. Inspect the O-rings (replace if necessary) and lubricate them with the silicone lubricant supplied or petroleum jelly (Vaseline®) (see Figure 5).
2. Assemble the blanking plug. Place the cap nut on top of the plug and attach the pull ring to capture the cap nut.
3. Remove the ultrasonic insert from the housing by removing the safety wire from the cap nut (see Figure 3).
4. Unscrew the cap nut to jack the insert out of the housing. This will remove the cap nut and insert as a single unit.

**Warning:** Always attach the safety wire to prevent the insert from backing out in the unlikely event that the cap nut fails or is screwed on incorrectly.

5. Slide the blanking plug into the housing with the arrow pointing forward toward the bow (see Figure 5). Seat it into place with a twisting motion until the key fits into the notch. Screw the cap nut in place and **hand-tighten** only. Do not over-tighten. Reattach the safety wire (see Figure 3).

## Servicing the Ultrasonic Insert

**Caution:** The active face of the ultrasonic insert is very fragile and easily damaged. Do not scratch, gouge, or sand it with coarse sandpaper.

Aquatic growth will seriously affect the ultrasonic insert's performance. Clean the active face with a dull putty knife *being careful* to avoid scratching the surface (see Figure 5). If fouling is severe, lightly wet sand the surface with fine grade (#320) wet/dry paper.

O-rings *must* be free of abrasions and cuts to ensure a watertight seal. Install the **large** O-ring near the cap nut, the **medium** O-ring below it, and the **small** O-ring near the active face. The three remaining O-rings are placed in similar positions on the blanking plug (see Figure 5).

## Servicing the Valve Assembly

Should the valve fail, remove it for servicing. A replacement O-ring and Valve Kit 33-450-01 is available.

1. On the blanking plug, inspect (replace if necessary) and lubricate the O-rings with silicone lubricant or petroleum jelly (Vaseline®).

4

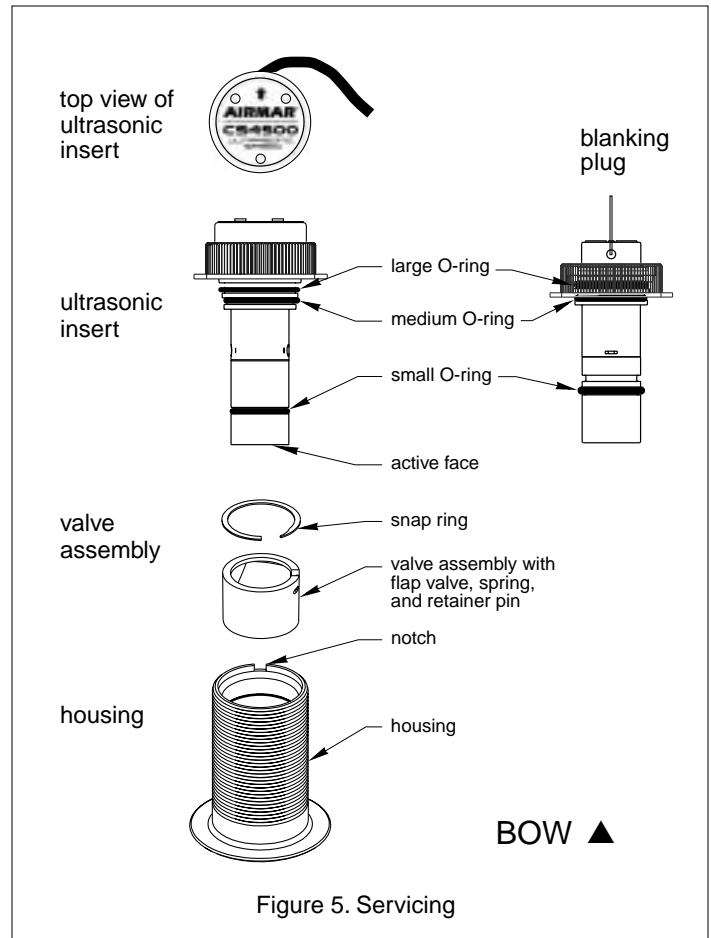

Figure 5. Servicing

2. Remove the ultrasonic insert from the housing (see Figure 3).
3. Remove the snap ring from the valve assembly using a screwdriver to pry the end of the ring free (see Figure 5).
4. Slide the valve assembly upward and out of the housing slowly. Note: The flap valve retainer pin is a loose slip-fit and may slide out when the assembly is removed.
5. Slide the blanking plug (or ultrasonic insert) into the housing with the arrow on the top pointing forward toward the bow. Seat the plug into place with a twisting motion until the key fits into the notch. Screw the cap nut in place and **hand-tighten** only. Do not over-tighten. Reattach the safety wire (see Figure 3).
6. Clean, repair, or replace the valve assembly so the flap valve moves freely and seats against the valve housing (see Figure 5).
7. Remove the blanking plug. Slide the valve assembly into the housing with the flap valve pointing downward. Insert the snap ring *being certain* that it **locks into the groove** in the housing wall.  
**Warning:** Always attach the safety wire to prevent the insert from backing out in the unlikely event that the cap nut fails or is screwed on incorrectly.
8. Slide the ultrasonic insert into the housing with the arrow on the top pointing forward toward the bow. Screw the cap nut until there is resistance. Seat the ultrasonic insert into place by rotating it until the key clicks into the notch. Continue to screw the cap nut into place **hand-tightening** only. Do not over-tighten. Re-attach the safety wire (see Figure 3).

# Wiring

## Tools and Materials

- Pencil
- Drill
- Drill bit: 3mm or 1/8"
- Cutting pliers
- Phillips screwdriver
- Wire strippers
- Electrical tape
- Blade screwdrivers

## Locating the Junction Box and Cable Routing

**Caution:** Minimize electrical interference by separating the sensor cables from other electrical wiring and the engine.

**Caution:** Be careful not to tear the cable jackets when passing them through the bulkhead(s) and other parts of the boat.

1. Select a convenient, *dry*, mounting location for the waterproof junction box, about 1–2m (3' – 5') from the instrument (see Figure 6).
2. Route the sensor cable to the proposed location of the junction box. *Do not* fasten the cable in place at this time.
3. Hold the junction box at the selected location and mark the position of the four screw holes with a pencil.  
**Note:** If the junction box will be mounted on a vertical surface, face the compression bushings downward to avoid water seeping into the box.
4. At the marked locations, drill a 3mm or 1/8" hole to a depth of 10mm (3/8"). *Do not* screw the junction box in place at this time.
5. Route the instrument cable to the junction box. Cut the cable 50cm (2') beyond the junction box to allow for wiring ease. *Do not* fasten the cable in place at this time.
6. Route the power cable from the battery to the junction box. Allowing 25cm (10") at each end for wiring ease, cut the cable to length. *Do not* fasten the cable in place at this time.

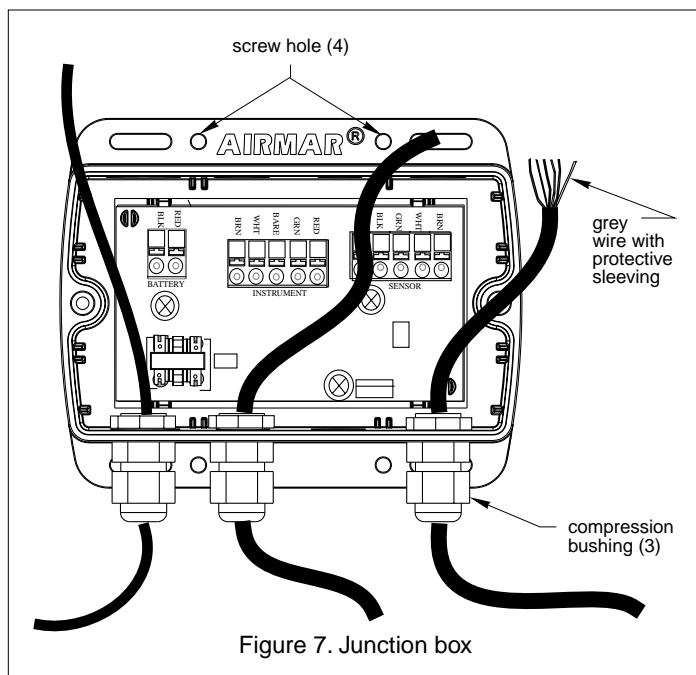

Figure 7. Junction box

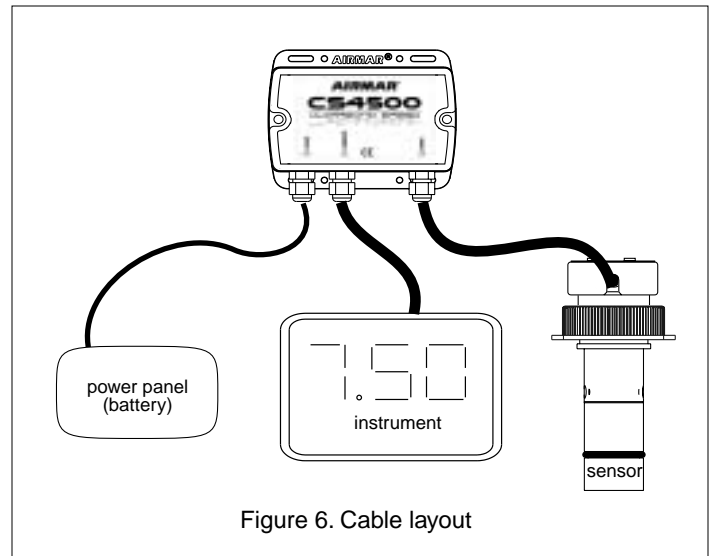

Figure 6. Cable layout

## Preparing the Cables

**WARNING:** The power must be "off" before proceeding.

1. Remove the junction box cover (see Figure 7).
2. Push approximately 200mm (8") of the power cable through the left compression bushing, *being careful* not to damage the circuit board.
3. Push approximately 200mm (8") of the instrument cable through the center compression bushing, *being careful* not to damage the circuit board.
4. Push approximately 200mm (8") of the sensor cable through the right compression bushing. *Be careful* not to damage the circuit board and the stripped wires.  
  
*Note: The grey wire is covered with protective sleeving and this must remain in place.*
5. Strip 60mm (2-1/2") of the outer jacket and foil shielding from the cut ends of the power and instrument cables (see Figure 8).
6. Strip 11mm (3/8") of conductor insulation from the end of each insulated wire in the power and instrument cables.
7. Protect the cable's foil shielding from causing a short inside the junction box. Wrap electrical tape around the jacket where the wires emerge from the cable. The tape *must* overlap the wires a minimum of 6mm (1/4").

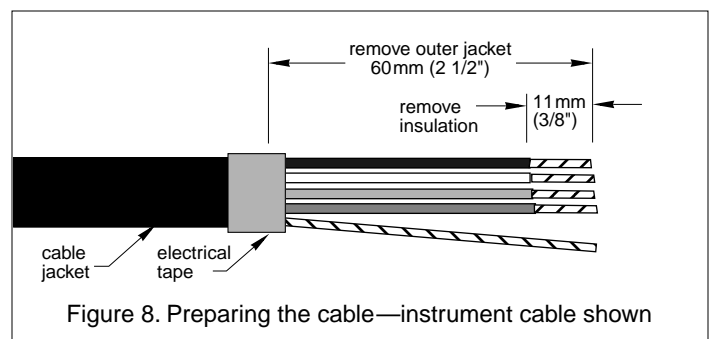

Figure 8. Preparing the cable—instrument cable shown

## Wiring the Junction Box

1. From outside the junction box, *carefully* pull each of the cables in turn until only 13mm (1/2") of the cable jacket remains inside the box (see Figure 9).
2. Starting with the battery cable, wire each cable in turn to the corresponding terminal block. Follow the color code on the PC board. Insert the stripped end of a wire in the hole in the corresponding terminal. Simultaneously depress the adjacent button using a small blade screwdriver. Release the button to lock the wire in place. *Be sure the stripped end of the wire is inserted up to the insulation only. Do not* include any insulation inside the terminal. Gently tug on the wire to ensure it is locked in place. Repeat this process until all wires are connected.

**Caution: Sensor cable—Do not attempt to connect the bare wire and grey wire. The bare wire has been cut off flush with the cable jacket, and the grey wire has been covered with protective sleeving. Do not allow these wires to short anything in the junction box.**

3. Hand-tighten the nut on each compression bushing to make a waterproof seal.
4. Arrange the wires neatly inside the junction box *being sure* that no bare wires are touching.
5. Attach the junction box cover with the screws provided for a waterproof seal.
6. Using the screws provided, attach the junction box to the selected mounting surface at the holes previously drilled.

## Wiring the Instrument

To connect the instrument cable to the display, follow the instructions in your instrument owner's manual for connecting a speed sensor. See the color code below.

Red	B+ (5 to 15V)
Green (GRN)	signal
Bare	ground
White (WHT)	temperature
Brown (BRN)	temperature

## Wiring the Power Panel (Battery)

**Warning:** The power panel must have a 1/2 amp fast blow fuse or breaker.

Cut off the bare wire flush with the cable jacket. To connect the power cable to the power panel, see the color code below.

Red	+10 to 15 VDC
Black (BLK)	- VDC

## Troubleshooting

### No Speed Reading

- Is the ultrasonic insert installed in the housing and connected to the junction box?
- Is the ultrasonic insert oriented with the arrow on the top pointing forward toward the bow? If the insert cannot be seated in the housing with the arrow pointing forward, check that the arrow on the lip of the housing is pointing forward toward the bow. If this is not the case, the housing needs to be reinstalled with the proper orientation.
- Is power being supplied to the junction box? The power *must* be 10-15VDC. At lower voltages performance is degraded and the unit will shut down. If there is no voltage, check the wiring.

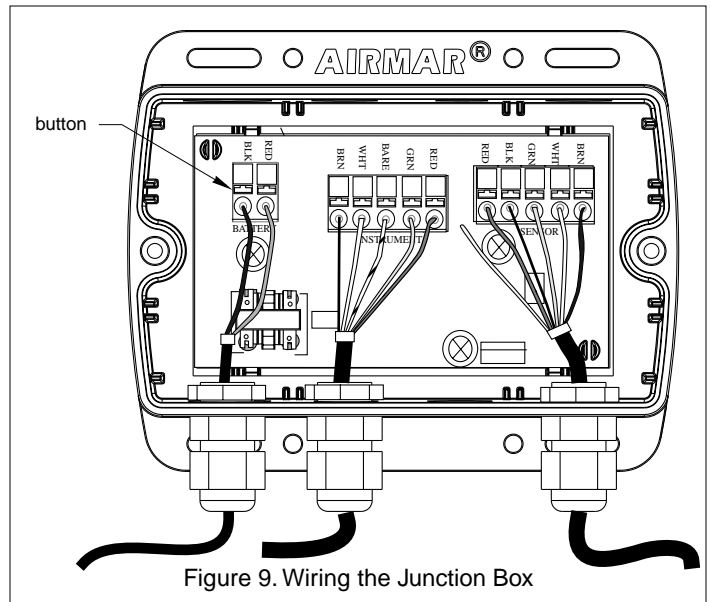

Figure 9. Wiring the Junction Box

- Are the wire connections at the terminals in the junction box tight and properly stripped of insulation?
- Does the color of each wire match the color label on the PC board?

### Inaccurate Speed Readings

- If the ultrasonic speed sensor is "on" when the boat is stationary, you may see a speed readout of a fraction of a knot because of water movement under the hull.
- If the speed reading is consistently the same percentage higher or lower than the true speed, the speed function within the instrument needs to be recalibrated. Follow the instructions in your instrument owner's manual.
- If speed readings are inaccurate above about 10knots:
  - The sensor is installed in turbulent water. The cause may be water intake or discharge openings, strakes, fittings, hull irregularities upstream of the sensor, or the shape of the hull in that area. The sensor must be re-installed in another location.
  - The ultrasonic insert is covered with aquatic growth. See "Servicing the Ultrasonic Insert" on page 4.
  - Aerated water is flowing across the sensor because the boat is designed to pull air under the hull. The sensor will not work on this type of boat.

## Replacement Parts

If you have purchased a plastic housing and have a wood hull or desire greater strength, purchase a bronze housing. Obtain the following parts from your marine dealer or instrument manufacturer.

Blanking Plug	Cap Nut	Hull Nut	Housing, Washer & Hull Nut	O-ring & Valve Kit
20-600	04-234-1 (plastic) 02-131-01 (bronze)	04-004 (plastic) 02-030 (bronze)	33-340-02 (plastic) 33-340-01 (bronze)	33-450-01

### Sensor Replacement

The information needed to order a replacement Airmar sensor is printed on the cable tag. *Do not* remove this tag. When ordering, specify the part number and date.