

# OWNER'S GUIDE &

# INSTALLATION INSTRUCTIONS

Transom-Mount *with Integrated Release Bracket*

## Depth Transducer or TRIDUCER® Multisensor

Models: **P66, P66S Smart™ Sensor**

Patents apply to TRIDUCER® models. U.S. Patent No. 7,369,458  
UK Patent No. 2 414 077.

08/23/17

17-247-03 rev. 06

Record the information found on the cable tag for future reference.

Part No. \_\_\_\_\_ Date \_\_\_\_\_ Frequency \_\_\_\_\_ kHz

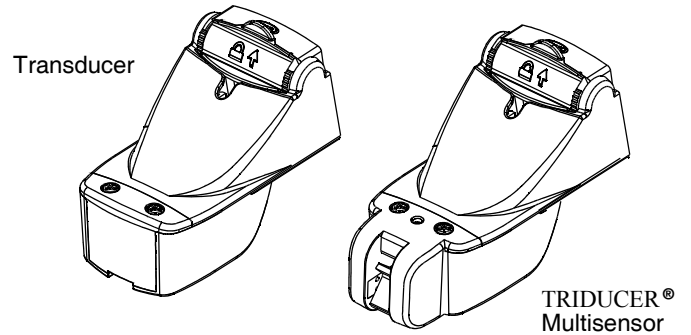

**Follow the precautions below for optimal product performance and to reduce the risk of property damage, personal injury, and/or death.**

**WARNING:** Always wear safety glasses, a dust mask, and ear protection when installing.

**WARNING:** When the boat is placed in the water, immediately check for leaks around the screws and any other holes drilled in the hull.

**CAUTION:** Do not attach the sensor to the bracket before fastening the bracket to the hull. It is VERY difficult to separate them if the bracket is unattached.

**CAUTION:** Never pull, carry, or hold the transducer by the cable as this may sever internal connections.

**CAUTION:** Never strike the multisensor with anything except the palm of the hand. Never strike the paddlewheel.

**CAUTION:** Never use solvents. Cleaner, fuel, sealant, paint, and other products may contain solvents that can damage plastic parts, especially the transducer's face.

**IMPORTANT:** Please read the instructions completely before proceeding with the installation. These instructions supersede any other instructions in your instrument manual if they differ.

## Applications

- Not recommended for boats with large inboard engine(s)
- Not recommended for stepped hull
- Good operation up to 44kn (50MPH)
- Vertically orients sound beam on hull with deadrise angle up to 30°
- Adjusts to transom angles from 2°–22°
- Bracket protects sensor from frontal impact only

## Tools & Materials

Safety glasses

Dust mask

Ear Protection

Scissors

Masking tape

Electric drill

Drill bits and hole saws:

Bracket holes 4mm, #23, or 9/64"

Transom hole (optional) 21mm or 13/16"

Cable clamp holes 3mm or 1/8"

Angle finder

Marine sealant (suitable for below waterline)

Screwdrivers

Straight edge

Pencil

Grommet(s) (some installations)

Cable ties

Water-based anti-fouling paint (**mandatory in salt water**)

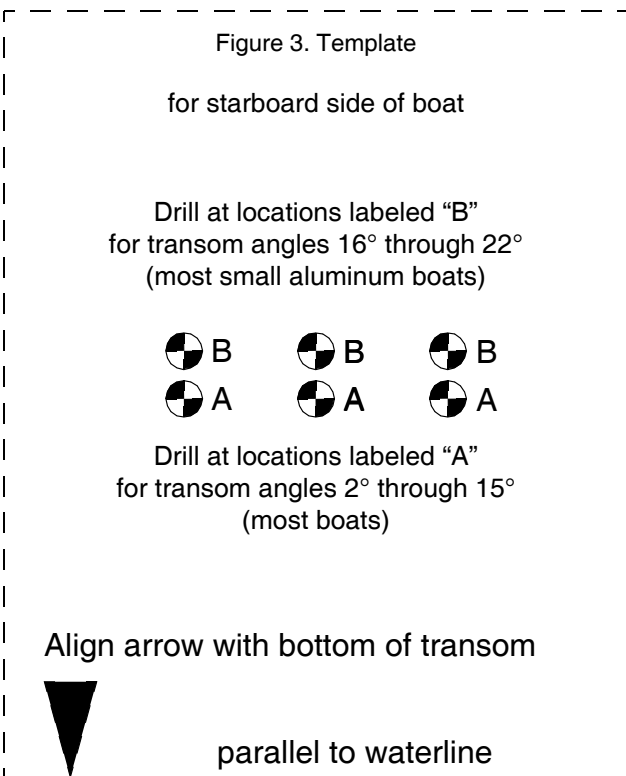
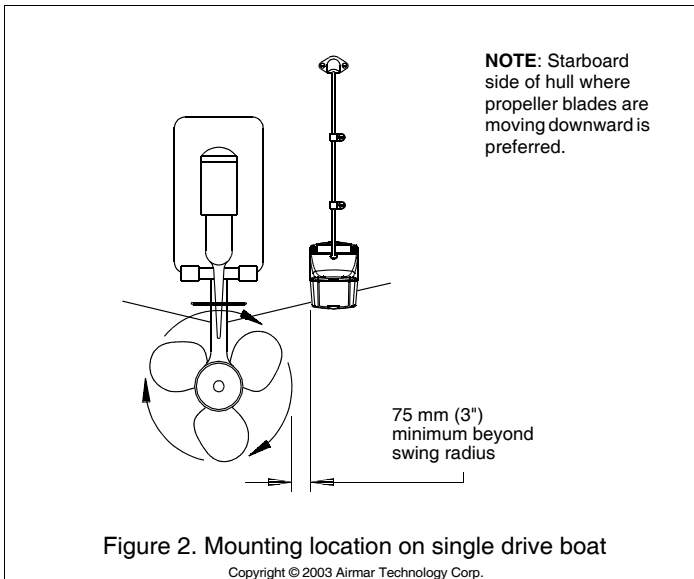
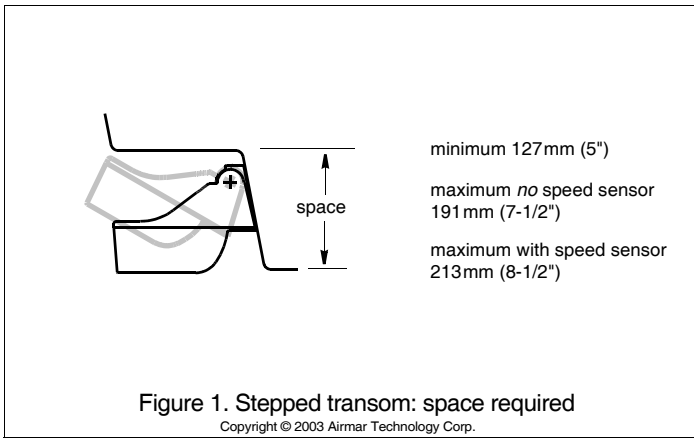

## Mounting Location

**CAUTION:** Do not mount in line with or near water intake or discharge openings or behind strakes, fittings, or hull irregularities that will disturb the water flow.

**CAUTION:** Do not mount the sensor in a location where the boat may be supported during trailering, launching, hauling, or storage.

- For the best performance, the sensor must be in contact with smooth water. To identify an area of 'clean' (non-turbulent) water, observe the water flow off the transom while the boat is underway.
- Allow space above the bracket for it to release and rotate the sensor upward (Figure 1).
- Mounting the sensor on the starboard side of the hull where the propeller blades are moving downward is preferred.
- Mount the sensor as close to the centerline (keel) of the boat as possible to ensure the transducer's face remains in the water when the boat is turning.
  - **Single drive boat**—Mount at least 75 mm (3") beyond the swing radius of the propeller (Figure 2).
  - **Twin drive boat**—Mount the sensor between the drives.

## Pretest Speed & Temperature Functions

Connect the multisensor to the instrument and spin the paddlewheel. Check for a speed reading and the approximate air temperature. If there is no reading(s) or it is inaccurate, check the connections and repeat the test. If there is still no reading(s) or it is inaccurate, return the product to your place of purchase.

## Installation

**CAUTION:** Install the bracket before attaching the sensor.

### Hole Drilling

**CAUTION:** To prevent drilling too deeply, wrap masking tape around the bit 22mm (7/8") from the point.

**NOTE: Fiberglass hull**—Minimize surface cracking by running the drill in reverse until the gelcoat is penetrated.

1. Cut out the template (Figure 3).
2. At the selected location on the starboard side of the hull, position the template, so the arrow at the bottom is aligned with the bottom edge of the transom (Figure 4). *Being sure the template is parallel to the waterline, tape it in place.*
3. Using a 4mm, #23, or 9/64" bit, drill three holes 22mm (7/8") deep at the marked locations.

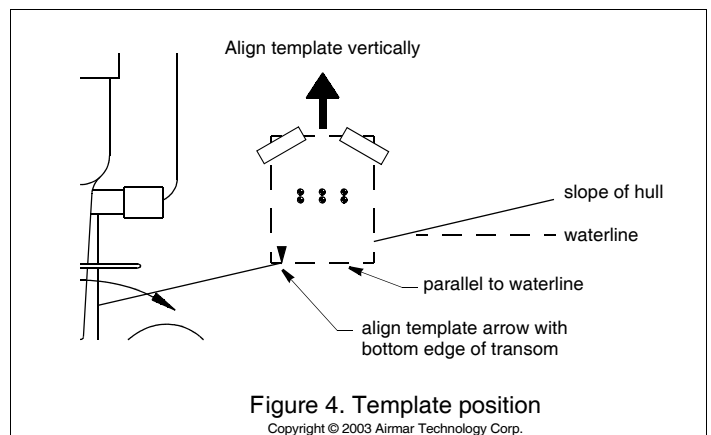

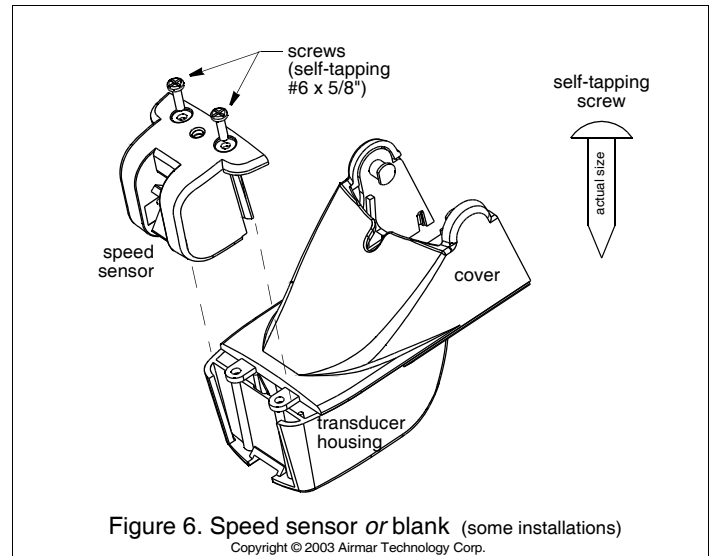
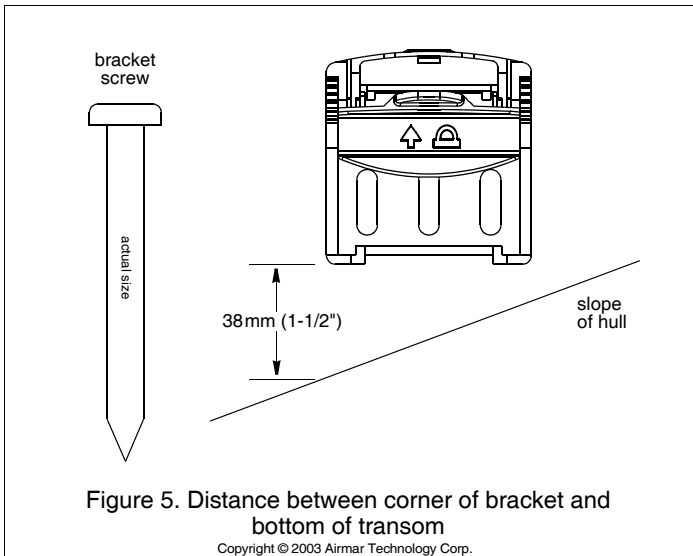

### Compensating for the Transom Angle: Shim

**CAUTION: For boats capable of speeds above 20kn (28MPH)—** The trailing edge of the sensor must be deeper in the water than the leading edge. This will ensure that the paddlewheel is in contact with the water at high speeds.

For the best performance, the transducer beam must be aimed straight at the bottom. Since the transom of most boats is angled, the bracket must compensate for it. Measure the transom angle of the boat with an angle finder.

- **Standard transom (13° transom angle)**—The bracket is designed for a standard 13° transom angle. The shim is NOT needed for this installation. Go to "Mounting the Bracket."
- **Stepped transom and jet boats (3° transom angle)**—Use the shim with the taper *down*.
- **Small aluminum and fiberglass boats (20° transom angle)**—Use the shim with the taper *up*.
- **If you are unsure about using the shim**—Experiment with the shim. Follow the instructions: "Mounting the Bracket", "Attaching the Sensor to the Bracket", and "Checking the Angle and Projection."

### Mounting the Bracket

1. Apply marine sealant to the threads of the three, #10 x 1-3/4", self-tapping screws to prevent water seepage into the transom (Figure 5). Screw the bracket (and shim if needed) to the hull. *Do not tighten the screws at this time.*
2. Using the vertical adjustment space on the bracket slots, slide the bracket up or down until the distance between the bottom left corner and the bottom of the transom equals 38mm (1-1/2"). Tighten the screws.

### Stepped Transom Only

If there is insufficient space under the step for the sensor to fully release, remove the cover before proceeding (Figure 1, maximum space). This is necessary to access the bracket screws at a later time.

1. Remove the two screws that hold the speed sensor onto the transducer housing (Figure 6).
2. The paddlewheel assembly is a loose slip fit. Carefully, slide the speed sensor upward while keeping the paddlewheel assembly inside (Figure 7).
3. Insert a blade screwdriver between the cover and the transducer housing (Figure 8). Pry each side apart, in turn.
4. Lift the cover up and off.

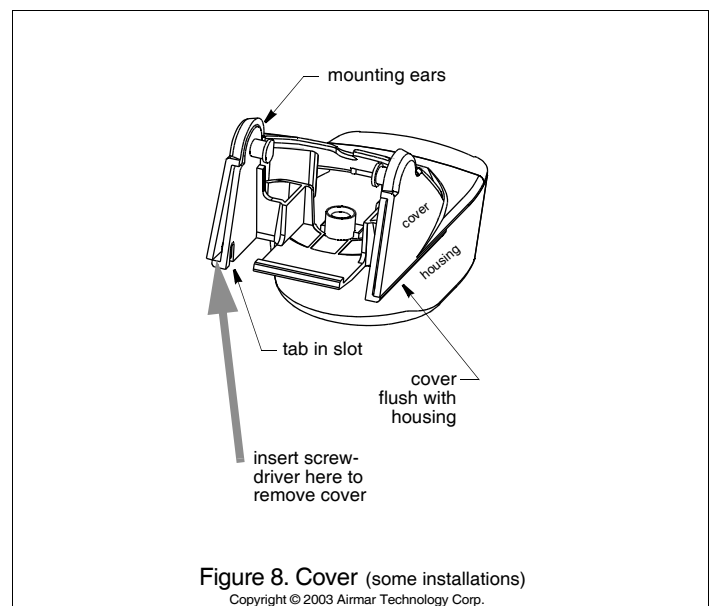
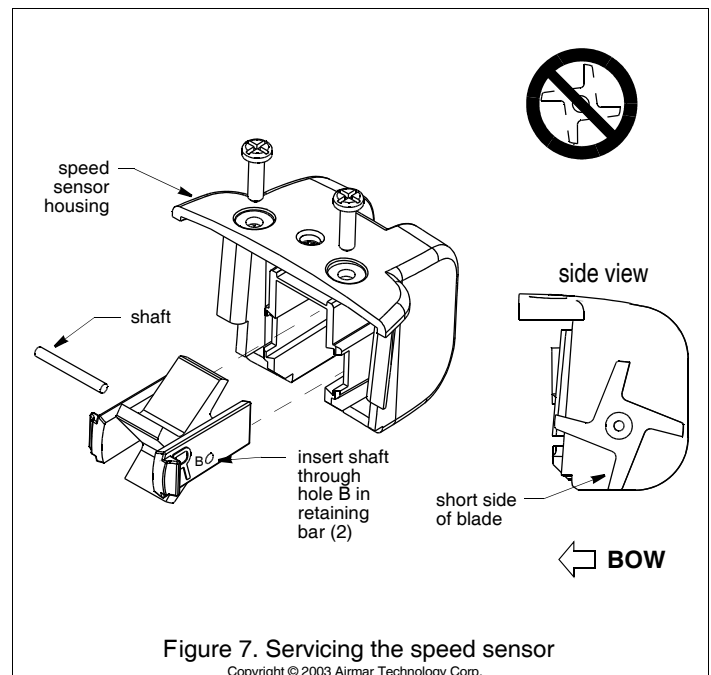

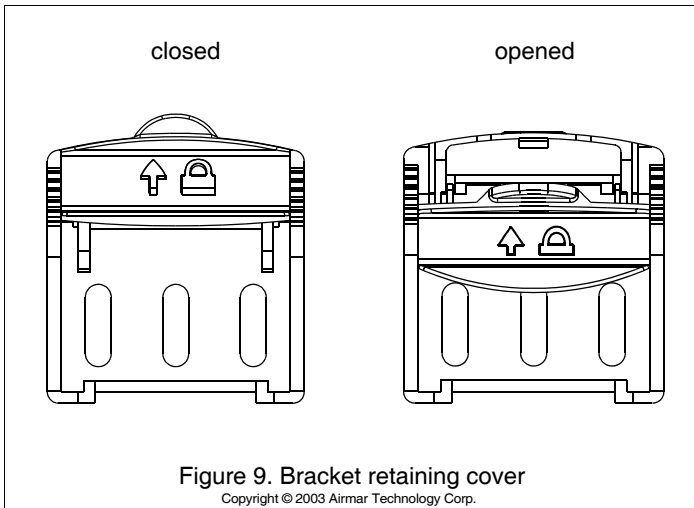

### Attaching the Sensor to the Bracket

**CAUTION:** The retaining cover must be closed and latched to prevent the sensor from coming off the bracket when the boat is underway.

1. If the retaining cover is closed, open it by depressing the latch and rotating the cover downward (Figure 9).
2. Insert the sensor's pivot posts into the slots in the top of the bracket (Figure 10). Push down until the posts click into place.
3. Rotate the sensor downward until it snaps onto the bracket.
4. Close the retaining cover by rotating it upward until it latches.

### Checking the Sensor Angle & Projection

**CAUTION:** Do not position the leading edge of the sensor lower than the trailing edge because aeration will occur.

**CAUTION:** Do not position the sensor deeper into the water than necessary to avoid increasing drag, spray, and water noise and reducing boat speed.

1. Using a straight edge, sight the underside of the sensor relative to the underside of the hull (Figure 11). The trailing edge of the sensor should be 1–3mm (1/16–1/8") below the leading edge of the sensor or parallel to the bottom of the hull.
2. Check that the bottom left corner of the sensor projections 3mm (1/8") below the bottom of the hull (Figure 12).
3. If the sensor needs adjustment, release it upward (see "Releasing the Sensor" below). Adjust the bracket. Tighten the screws.

### Releasing the Sensor

Do one of the following (Figure 13):

- *Using the palm of your hand*, give a sharp upward blow to the underside of the transducer housing. Do not hit the speed sensor.
- Insert a blade screwdriver between the transducer housing and the bottom of the bracket (either side). Push up on the screwdriver while lifting up on the sensor.

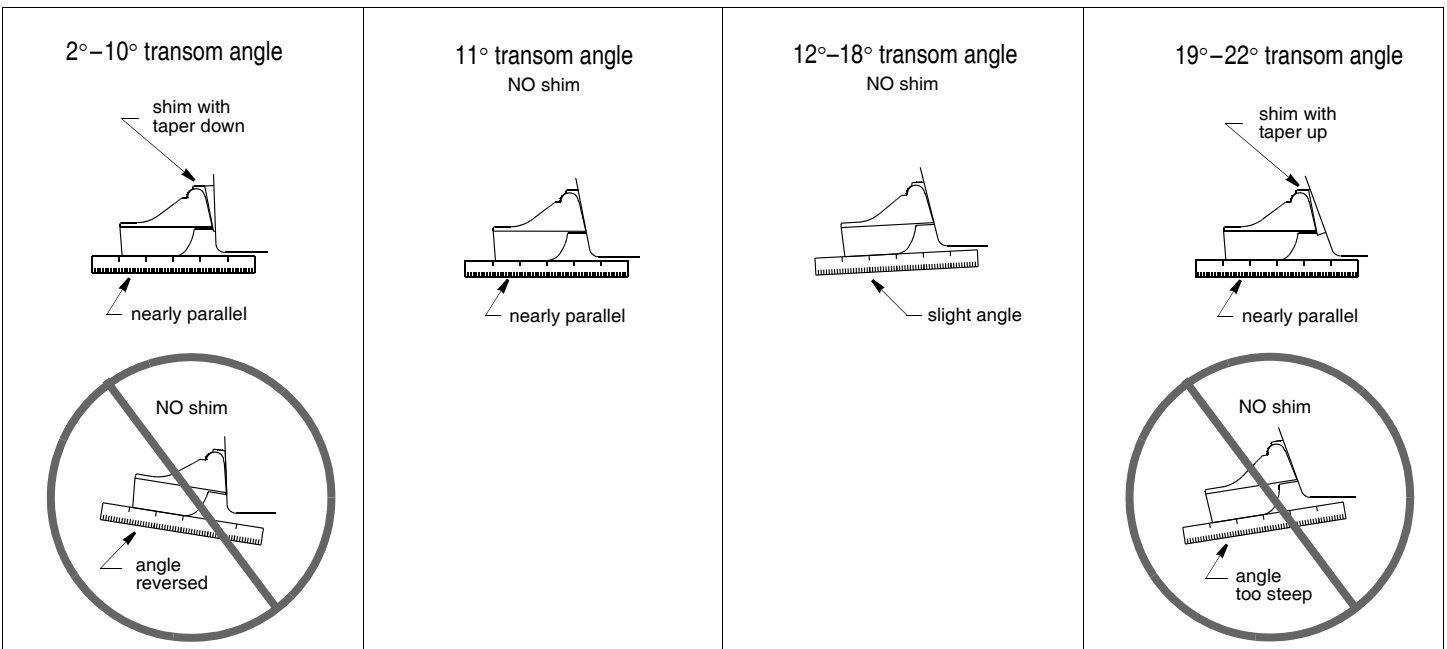
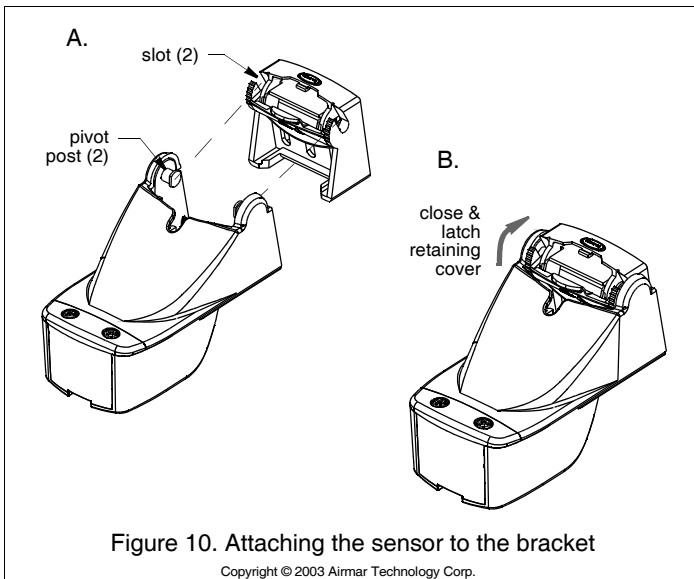

## Attaching the Speed Sensor or the Cover & Blank

(some installations)

1. Spread the sides of the cover horizontally (Figure 8).
2. Slide the cover up and over the mounting ears.
3. Push the cover down until it sits flush on the transducer.
4. Squeeze the sides of the cover until the tabs snap into the slots.
5. Insert the side rails of the speed sensor or blank into the channels on the back of the transducer housing (Figure 6). Slide it downward. Fasten the speed sensor *or* blank in place with the two, #6 x 5/8", self-tapping screws.

## Testing on the Water

1. Become familiar with your echosounder's performance at a speed of 4kn (5MPH).
2. Gradually increase the boat speed and observe the gradual decline in performance due to turbulent water flowing under the transducer's face.
3. If the decline in performance is sudden (not gradual), identify the boat speed at which the onset occurred. Return the boat to this speed, then gradually increase speed while making moderate turns in both directions.
4. If the performance improves while turning to the side on which the sensor is installed, the transducer's position probably needs adjustment. It is probably in aerated water.

**To improve performance, try the following one at a time in the order given.**

- a. Increase the sensor's angle, so the back of the sensor is deeper in the water (see Figure 11, 12° - 18° and review "Checking the Sensor Angle & Projection").
- b. Move the sensor deeper into the water in increments of 3mm (1/8") (Figure 12).
- c. Move the sensor closer to the centerline of the boat. Fill unused screw holes with marine sealant.

**NOTE: High-speed operation [above 35kn (40MPH)] may require less projection in the water to improve performance and reduce the chance that water pressure will cause the bracket to release.**

5. **Calibration**—To match the speed shown on the display to the actual speed of the boat, you may need to calibrate the instrument. Refer to your instrument owner's manual.

## Cable Routing & Connecting

**CAUTION:** If the sensor came with a connector, do not remove it to ease cable routing. If the cable must be cut and spliced, use Airmar's splash-proof Junction Box No. 33-035 and follow the instructions provided. Removing the waterproof connector or cutting the cable, except when using a water-tight junction box, will void the sensor warranty.

Route the sensor cable over the transom, through a drain hole, or through a new hole drilled in the transom **above the waterline**.

1. If a hole must be drilled through the transom, choose a location **well above the waterline** (Figure 12). Check for obstructions such as trim tabs, pumps, or wiring inside the hull. Mark the location with a pencil. Drill a hole using the appropriate size bit to accommodate the connector.
2. Route the cable over or through the transom.
3. On the outside of the hull, secure the cable against the transom using the cable clamps. Position one cable clamp 50mm (2") above the bracket and mark the mounting hole with a pencil.

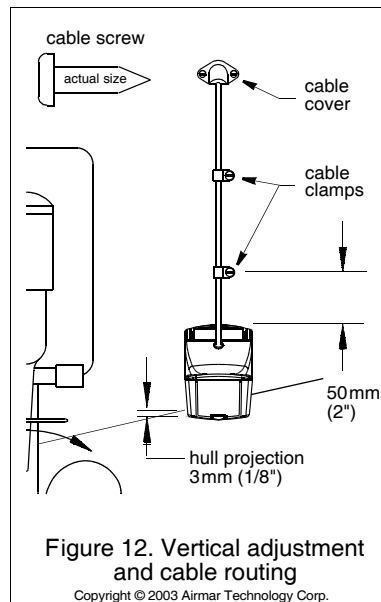

Figure 12. Vertical adjustment and cable routing

Copyright © 2003 Airmar Technology Corp.

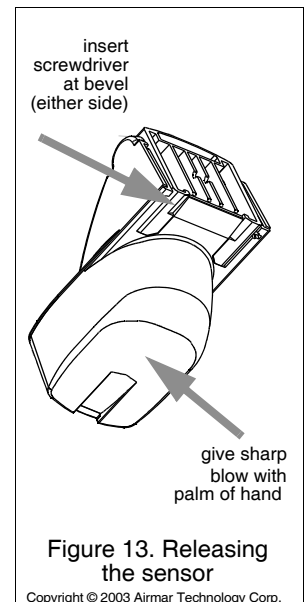

Figure 13. Releasing the sensor

Copyright © 2003 Airmar Technology Corp.

4. Position the second cable clamp halfway between the first clamp and the cable hole. Mark this mounting hole.
5. If a hole has been drilled in the transom, open the appropriate slot in the cable cover. Position the cover over the cable where it enters the hull. Mark the two mounting holes.
6. At each of the marked locations, use a 3mm or 1/8" bit to drill a hole 10mm (3/8") deep.
7. Apply marine sealant to the threads of the #6 x 1/2" self-tapping screws to prevent water from seeping into the transom. If you have drilled a hole through the transom, apply marine sealant to the space around the cable where it passes through the transom.
8. Position the two cable clamps and fasten them in place. If used, push the cable cover over the cable and screw it in place.
9. Route the cable to the instrument being careful not to tear the cable jacket when passing it through the bulkhead(s) and other parts of the boat. Use grommets where appropriate. To reduce electrical interference, separate the sensor cable from other electrical wiring and the engine(s). Coil any excess cable and secure it in place with cable ties to prevent damage.
10. Refer to your echosounder owner's manual to connect the sensor to the instrument.

## Checking for Leaks

When the boat is placed in the water, **immediately** check for leaks around the screws and any holes drilled in the hull. Note that very small leaks may not be readily observed. Do not leave the boat in the water unchecked for more than three hours.

## Anti-fouling Paint

Surfaces exposed to salt water that do not interlock, must be coated with anti-fouling paint. *Use water-based anti-fouling paint only.* Never use ketone based paint, since ketones can attack many types of plastic possibly causing damage to the transducer. Repaint every 6 months or at the beginning of each boating season.

## Maintenance, Repair & Parts

### Cleaning

Aquatic growth can accumulate rapidly on the sensor's surface reducing performance within weeks. Clean the transducer's face with a Scotch-Brite® scour pad and mild household detergent taking care to avoid making scratches. If the fouling is severe, lightly wet sand with fine grade wet/dry paper.

### Servicing the Speed Sensor

**CAUTION:** The paddlewheel must be oriented correctly to measure boat speed.

If the paddlewheel becomes fouled or inoperable, remove it for cleaning. Remove the two screws from the speed sensor (Figure 14). Slide it upward to remove it from the transducer housing. Grasp the two retaining bars and pull to access the shaft.

After cleaning, slide the paddlewheel onto the shaft. *Orient the short side of the paddlewheel blade as shown on the side view. It must be oriented correctly to measure the boat's speed.* Fit the shaft into the holes marked "B" in the retaining bars. *Note: There is a left retaining bar marked with an L and a right retaining bar marked with an R.* Slide the assembly into the speed sensor housing. *Note: The interior of the housing is marked with a corresponding L and R.* Re-attach the speed sensor.

### Replacement Sensor & Parts

The information needed to order a replacement sensor is printed on the cable tag. Do not remove this tag. When ordering, specify the part number, date, and frequency in kHz. For convenient reference, record this information on the top of page one.

Replace broken or worn parts immediately. The water-lubricated paddlewheel bearings have a life of up to 5 years on low-speed boats [less than 10kn (11MPH)] and 2 years on high-speed vessels. Some depth/temperature units can be upgraded by adding a speed sensor.

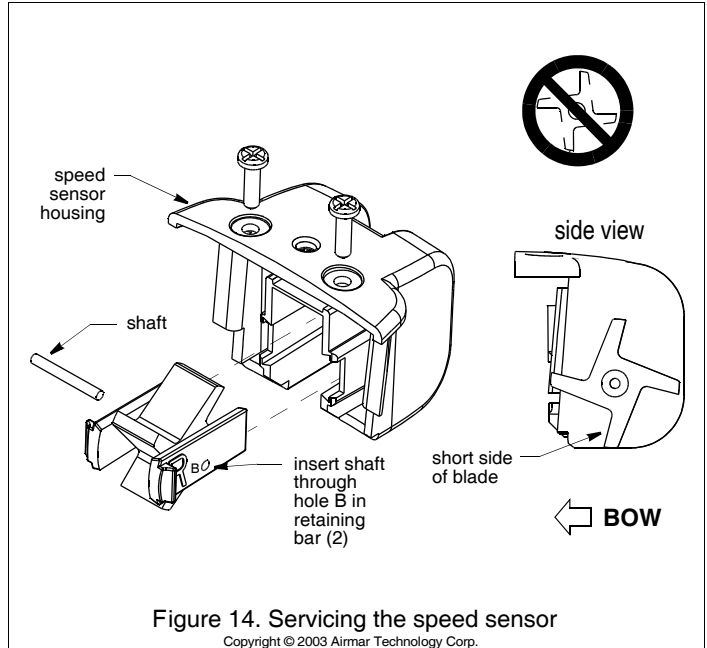

<u>Part</u>	<u>Part Number</u>
Paddlewheel Kit	33-473-01
Bracket and Wedge Kit	33-479-01
Speed Sensor Kit	33-346-03

Obtain parts from your instrument manufacturer or marine dealer.

#### Gemeco

#### USA

Tel: 803-693-0777  
email: sales@gemeco.com

#### Airmar EMEA

#### Europe, Middle East, Africa

Tel: +33.(0)2.23.52.06.48  
email: sales@airmar-emea.com

Smart™ Sensors only



35 Meadowbrook Drive, Milford, New Hampshire 03055-4613, USA  
•www.airmar.com

Copyright © 2000 - 2017 Airmar Technology Corp. All rights reserved.