

# R209

# 2 to 3 kW

Dual-Frequency

## Preliminary



## Deep-water detection at its best.

### Meet the Biggest and Baddest!

Want to increase your catch? Want to detect ground fish holding tight to the bottom in deep-water? Want to mark bait fish as closely-spaced, individual fish? Then Airmar's R209 is the answer.

### Frequency Agility

Airmar's Broadband R209 can operate at ANY frequency between 33 kHz to 60 kHz and 130 kHz to 210 kHz. Adjusting the frequency allows you to change the R209's beamwidth and depth capabilities. For example if you are bottom fishing in 61 m (200') of water, the narrow high-frequency beam will display extreme bottom detail and fish holding tight to structure. If you are tuna or marlin fishing in deep blue water, the wider, low-frequency beam will not only give deep-water bottom detail, but more importantly show you more of what is around your vessel—including bait which may attract game fish. With the R209, you choose the frequency for your fishing.

- The top performer in Airmar's professional line of fishfinder transducers
- Only transducer on the market that can operate at both 38 or 50 kHz
- Recommended for commercial and sport fishing boats above 12 m (40')
- Fast-response water-temperature sensor
- Unique design lets the transducer connector pass through the stuffing tube
- Includes fairing and stainless steel stuffing tube
- Xducer ID™ feature

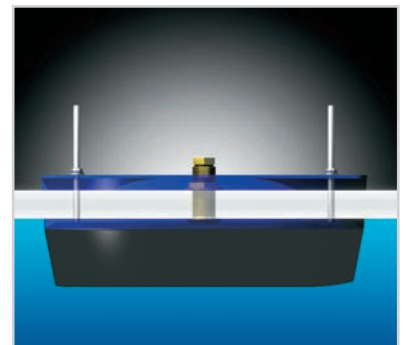



# R209

# 2 to 3 kW

Dual-Frequency

## Technical Information

### Specifications

Frequencies	Number of Elements and Configuration	Rated RMS Power (W)	TVR	RVR
33-60 kHz-A		3 kW	171dB	-177dB
130-210 kHz-BRLq		2 kW	172dB	-184dB

Weight: ..... 20.8 kg (46 lb)

Hull Deadrise Angle: ..... 0° to 25°

	33-60 kHz	130-210 kHz
FOM*	-7	-12
Q	2	2

\*does not calculate losses through the hull.

### Figure of Merit

The graph shows that the R209 can run optimally at a wide range of frequencies.

As Airmar constantly improves its products, all specifications are subject to change without notice. All Airmar products are designed to provide high levels of accuracy and reliability; however, they should only be used as aids to navigation and not as a replacement for traditional navigation aids and techniques.

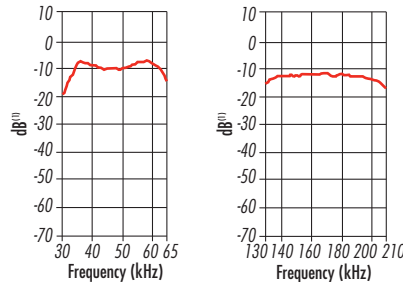

### R209 Dimensions

R209 transducer

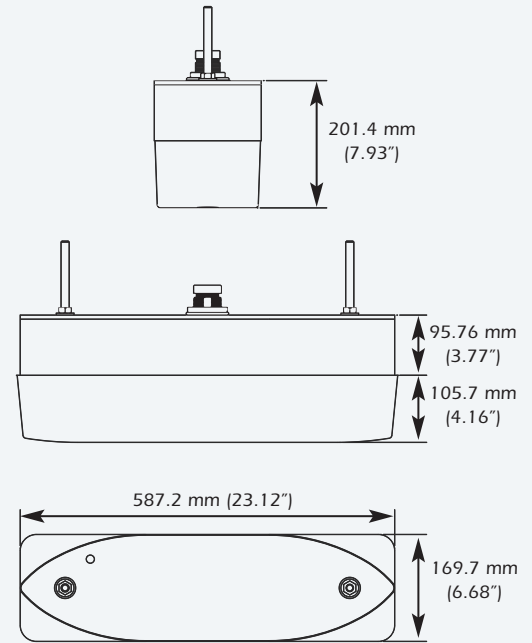

### Directivity Patterns

