

IP 56

IMO
BSH



12 V
24 V

BAY 15d



10 / 25 W

Navigation lights aqua signal 50

Application: All vessels < 20 m in length. Lights marked with index ⚓ may also be used on inland waterways without limitation of ship's length. Applicable on national waterways up to the border of the high seas

Approvals: International according to IMO 1972, in Germany through BSH, other countries in particular see list of approvals. For inland waterways approval under ⚓ D

Min. visibilities: 2 n.m., masthead 3 n.m., masthead strong 5 n.m.

Protection class: IP 56

Housing: Stainless steel, nonmagnetic, seawater resistant

Optics: Rigid acrylic lens

Electric: Bulb holder with 2 - pole screw type terminals

Cable insert: PG 9 from below. Navigation lights for hoisting with additional cable clamp

Lamp (included): Easy to change, special vertical filament tungsten bulb with socket BAY 15 d

Mounting: Running lights: in short bracket. Allround lights with halyard hooks: through hoisting. Allround lights for fixed mounting: 3 screws Ø 4 mm. Further mounting aids see drawing

Navigationslaternen aqua signal 50

Einsatzbereich: Wasserfahrzeuge < 20 m Länge. Alle in der Tabelle mit ⚓ gekennzeichneten Laternen dürfen auf europäischen Binnenschiffen gefahren werden. Die Längenbegrenzung ist dann aufgehoben. Zur Verwendung auf Seeschiffahrtsstraßen bis zur Grenze der Seefahrt

Zulassung: International entsprechend IMO 1972. In Deutschland durch das BSH, andere Länder siehe Zulassungstabelle. Für die europäische Binnenschifffahrt unter ⚓ D zugelassen

Mindesttragweite: 2 sm, Toplaterne 3 sm, Toplaterne weiß stark 5 sm

Schutzklasse: IP 56

Gehäuse: Edelstahl. Amagnetisch, seewasserfest

Optik: Schlag- und stoßfeste Acrylglaslinse

Elektrik: Fassung mit Schraubanschluß 2polig

Kabeleinführung: PG 9 von unten. Laternen zum Vorheißern mit zusätzlicher Kabelzugentlastung

Leuchtmittel (gehört zum Lieferumfang): Leicht auswechselbare Spezialglühlampe mit Sockel BAY 15 d

Montage: Mit Steckhalter. Signallaternen mit 3 Schrauben Ø 4 mm. Signallaternen mit Ober- und Unterbügel durch Vorheißern. Anbauzubehör siehe Zeichnung



Type / Typ	Part No. / Bestell-Nr.		kg	
	12 V	24 V		
1 x 25 W	Starboard / Steuerbord	⚓ 3036102 3036103	0,44	
	Port / Backbord	⚓ 3035202 3035203	0,44	
	Bicolor side / doppelfarbige Seiten	⚓ 3033302 3033303	0,40	
	Masthead / Topp	⚓ 3030002 3030003	0,40	
	Masthead white STRONG / Topp weiß STARK	⚓ 3087002 3087003	0,40	
1 x 10 W	Stern / Heck	⚓ 3034002 3034003	0,45	
	Stern yellow / Heck gelb	⚓ 3091402 3091403	0,45	
1 x 10 W	Allround for hoisting /	white / weiß	⚓ 3037002 3037003	0,38
1 x 25 W	Signal zum Vorheißern	white bright / weiß hell	⚓ 3083002 3083003	
1 x 10 W		white ordinary / weiß gew.	⚓ 3086002 3086003	
1 x 25 W		red / rot	⚓ 3038202 3038203	
		green / grün	⚓ 3039102 3039103	
		yellow / gelb	⚓ 3058402 3058403	
	1 x 10 W	Allround with pedestal /	white / weiß	⚓ 3037012 3037013
1 x 25 W	Signal für Festanbau	white bright / weiß hell	⚓ 3083012 3083013	
1 x 10 W		white ordinary / weiß gew.	⚓ 3086012 3086013	
1 x 25 W		red / rot	⚓ 3038212 3038213	
		green / grün	⚓ 3039112 3039113	
		yellow / gelb	⚓ 3058412 3058413	

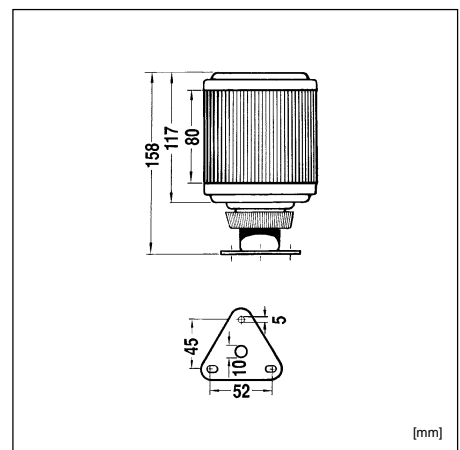
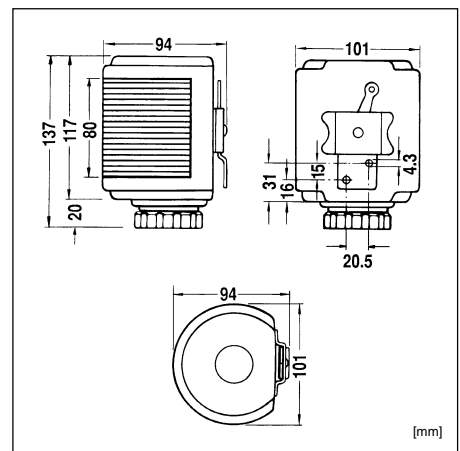

Busse-Yachtshop.de
Burkamp 6
24220 Flintbek bei Kiel



Tel: 04347 9082 34
Fax: 04347 9082 35
info@busse-yachtshop.de

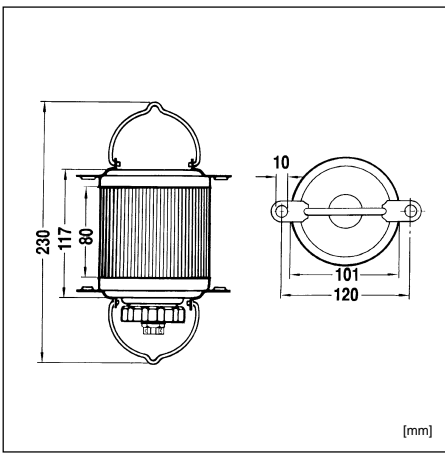

Spare Parts / *Extras – Ersatzteile / *Zubehör

Allround/Signal
white/weiß **83037010**
red/rot **83038002**
yellow/gelb **83058002**
green/grün **83039002**
white bright/weiß hell
83083017
white ordinary/weiß gewöhnlich
83086002

12V/25W
90400002
24V/25W
90400003
12V/10W
90400005
24V/10W
90400006

83037009

95800099

83037002
83057003
with cable clamp/mit Kabelklemme

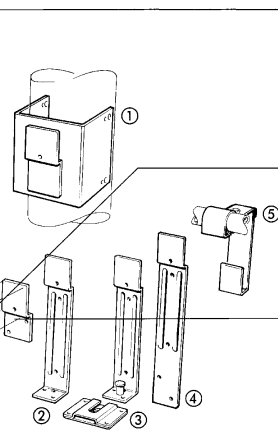
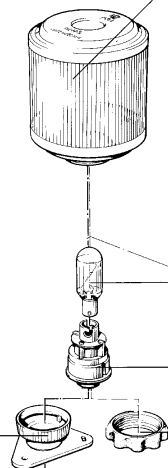
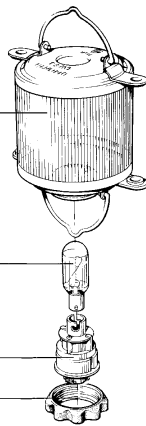

Allround/Signal
white/weiß **83037011**
red/rot **83038001**
green/grün **83039001**
yellow/gelb **83058001**
white bright/weiß hell
83083008
white ordinary/weiß gewöhnlich
83086001

Starboard/Steuerbord
83035002
Port/Backbord **83036002**
Masthead/Topp **83030003**
bicolour/doppelfarbig
83033002
Stern/Heck **83034002**
Masthead white STRONG/
Topp weiß STARK
83087001
Stern yellow/Heck gelb **83091001**

63030009

12V/25W
90400002
24V/25W
90400003
12V/10W
90400005
24V/10W
90400006

83030006

95800099

- ① Mast bracket / Masthalter ***83501004**
- ② Bent bracket / Halter abgewinkelt, H 160 mm ***63030012**
- ③ Bent bracket / Halter mit Arretierungsblech, H 160 mm ***3908001**
- ④ Multi-purpose bracket / Halter, H 195 mm ***63030011**
- ⑤ "Easy to fit" pulpit bracket / Relingshalter ***3902001**
Cable adapter PG 13.5 for hoistable version /
Kabelverschraubung PG 13.5 für vorheizbare Laterne ***83080002**

* Extras not included / *Zubehör gehört nicht zum Lieferumfang

List of approvals for aqua signal navigation lights / Zulassungsliste für aqua signal Navigationslaternen

Country:	Länder:	GB	CDN	D	AUS	NL	F	SF	N	DK	S	IS	PL
Authority:	zugelassen durch:	DOT/MSA	DOT	BSH	AMSA	DGSM	MM/CCS	MKH	NMD	DMA	NMA	SR	PRS
aqua signal 20													
Masthead	Topp	7*	7		7*	8	8						7*
Side lights	Seiten	7*	7		7*	8	8						7*
Side lights/top mount	Seiten/Anbau	–	7		–	8	8						7*
Bicolour	doppelfb. Seiten	7*	7		7*	8	8						7*
Stern	Heck	7*	7		7*	8	8						7*
Allround white	Signal weiß	7*	7		7*	8	8						7*
aqua signal 25													
Masthead	Topp	2*	2*		2*	8	2*	2*	1*	2*	2*	1*	2*
Side lights	Seiten	2*	2*		2*	8	2*	2*	1*	2*	2*	1*	2*
Bicolour	doppelfb.Seiten	2*	2*		2*	8	2*	2*	1*	2*	2*	–	2*
Stern	Heck	2*	2*		2*	8	2*	2*	1*	2*	2*	1*	2*
Allround white	Signal weiß	2*	2*		2*	8	2*	2*	1*	2*	2*	1*	2*
Comb.Masth./Deck	Topp/Deckstrahler	2*	2*		2*	8	2*	2*	–	2*	2*	–	2*
aqua signal 40													
Masthead	Topp	3*	3*	3*	3*	3****	3*	3*	2*	3*	3*	2*	3*
Side lights	Seiten	3*	3*	3*	3*	3****	3*	3*	2*	3*	3*	2*	3*
Bicolour	doppelfb.Seiten	3*	3*	3*	3*	3****	3*	3*	2*	3*	3*	2*	3*
Stern	Heck	3*	3*	3*	3*	3****	3*	3*	2*	3*	3*	2*	3*
Stern yellow	Heck gelb	–	–	3*	–	3****	–	3*	–	–	3*	–	–
Tricolour	dreifb. Segler	3*	3*	3*	3*	3****	3*	3*	2*	3*	3*	–	3*
Tricolour/Anchor	dreifb. Segler/Signal	3*	3*	3*	3*	2****	3*	3*	2*	3*	3*	–	–
Allround lights	Signal	3*	3*	3*	3*	3****	3*	3*	2*	3*	3*	–	3*
Masth./Signal white	Topp/Signal weiß	3*	9	3*	9	3****	9	3*	9	3*	3*	–	–
aqua signal 41													
Masthead	Topp	3*	3*	3*	3*	3****	3*	3*	2*	3*	3*	3*	3*
Side lights	Seiten	3*	3*	3*	3*	3****	3*	3*	2*	3*	3*	3*	3*
Stern	Heck	3*	3*	3*	3*	3****	3*	3*	2*	3*	3*	3*	3*
Bicolour	doppelfb. Seiten	3*	3*	3*	3*	3****	3*	3*	2*	3*	3*	3*	3*
aqua signal 42													
Side lights	Seiten	3*	9	3*	9	3****	3*	3*	9	3*	3*	–	–
Stern	Heck	3*	9	3*	9	3****	3*	3*	9	3*	3*	–	–
aqua signal 50													
Masthead	Topp	3*	3*	3*	3*	3****	3*	3*	3*	3*	3*	3*	3*
Masth. 5nm (TW 50)	Topp 5 sm (TW 50)	4*	4*	–	4*	–	–	4*	–	–	–	–	–
Side lights	Seiten	3*	3*	3*	3*	3****	3*	3*	3*	3*	3*	3*	3*
Stern	Heck	3*	3*	3*	3*	3****	3*	3*	3*	3*	3*	3*	3*
Allround	Signal	3*	3*	3*	3*	3****	3*	3*	3*	3*	3*	3*	3*
aqua signal 55													
Masthead	Topp	5*	5*	5*	5*	5*	5*	5*	5*	5*	5*	5*	5*
Side lights	Seiten	5*	5*	5*	5*	5*	5*	5*	5*	5*	5*	5*	5*
Stern	Heck	5*	5*	5*	5*	5*	5*	5*	5*	5*	5*	5*	5*
Stern yellow	Heck gelb	5*	5*	5*	5*	5*	5*	5*	5*	5*	5*	5*	5*
Allround	Signal	5*	5*	5*	5*	5*	5*	5*	5*	5*	5*	5*	5*
aqua signal 70 (single optic / einlinsig)													
Masthead	Topp	6*	6*	6*	6*	6*	6*	6*	6*	6*	6*	6*	6*
Side lights	Seiten	6*	6*	6*	6*	6*	6*	6*	6*	6*	6*	6*	6*
Stern	Heck	6*	6*	6*	6*	6*	6*	6*	6*	6*	6*	6*	6*
Stern yellow	Heck gelb	6*	6*	6*	6*	6*	6*	6*	6*	6*	6*	6*	6*
Allround	Signal	6*	6*	6*	6*	6*	6*	6*	6*	6*	6*	6*	6*
Manoeuvring light	Manöver	6*	9	6*	9	6*	9	9	6*	6*	6*	9	6*
aqua signal 70 M / 70 D (double optic / doppellinsig)													
Masthead	Topp	6*	6*	6*	6*	6*	6*	6*	6*	6*	6*	6*	6*
Side lights	Seiten	6*	6*	6*	6*	6*	6*	6*	6*	6*	6*	6*	6*
Stern	Heck	6*	6*	6*	6*	6*	6*	6*	6*	6*	6*	6*	6*
Allround	Signal	6*	6*	6*	6*	6*	6*	6*	6*	6*	6*	6*	6*
aqua signal 55 class IV													
Sound signalling appliance	Schallsignalanlage	3*	3*	3*				3*	3*	3*	3*		

I	B	ZA	RUS	USA	GR	NZ	VRC	RC	RA
RINA	BZI	DOT	RS	USCG/BIA MOMB	MSA	CCS	CS	PNA	
7*	8	7*	8	7*	7*	7*	7	7	
7*	8	7*	8	7*	7*	7*	7	7	
–	8	7*	8	7*	7*	7*	7	7	
7*	8	7*	8	7*	7*	7*	7	7	
7*	8	7*	8	7*	7*	7*	7	7	
7*	8	7*	8	7*	7*	7*	7	7	
2*	8	8	8	2*	2*	2*	2	2	2*
2*	8	8	8	2*	2*	2*	2	2	2*
2*	8	8	8	2*	2*	2*	2	2	2*
2*	8	8	8	2*	2*	2*	2	2	2*
2*	8	8	8	2*	2*	2*	2	2	2*
2*	8	8	8	2*	2*	2*	2	2	2*
3*	3*	8	8	3*	3*	3*	3	3	3*
3*	3*	8	8	3*	3*	3*	3	3	3*
3*	3*	8	8	3*	3*	3*	3	3	3*
3*	3*	8	8	3*	3*	3*	3	3	3*
3*	–	8	8	3*	–	–	3	3	3*
3*	–	8	8	3*	3*	3*	3	3	3*
3*	3*	8	8	3*	3*	3*	3	3	3*
9	3*	8	8		3*	9	3	3	9
3****	8	8	8	3*	3*	3*	3	3	3*
3****	8	8	8	3*	3*	3*	3	3	3*
3****	8	8	8	3*	3*	3*	3	3	3*
3****	8	8	8	3*	3*	3*	3	3	3*
9	3*	8	8		3*	9	3	3	–
9	3*	8	8		3*	9	3	3	–
–	8		3*		3*	3	3	3*	
4*	8	–	3*		4*	4	4	4*	
–	8	–	3*		3*	3	3	3*	
3*	8	–	3*		3*	3	3	3*	
3*	8	–	3*		3*	3	3	3*	
4**	5*	5*	5***	5*	5*	5*	5**	5	5*
4**	5*	5*	5***	5*	5*	5*	5**	5	5*
4**	5*	5*	5***	5*	5*	5*	5**	5	5*
4**	5*	5*	5***	5*	5*	5*	5**	5	5*
4**	5*	5*	5***	5*	5*	5*	5**	5	5*
6**	6*	6*	6***	6*	6*	6*	6**	6	6*
6**	6*	6*	6***	6*	6*	6*	6**	6	6*
6**	6*	6*	6***	6*	6*	6*	6**	6	6*
6**	6*	6*	6***	6*	6*	6*	6**	6	6*
6**	6*	6*	6***	6*	6*	6*	6**	6	6*
9	6*	9	6***	–	6*	9	–	6	9
6**	6*	–	6***	6*	6*	6*	6**	6	6*
6**	6*	–	6***	6*	6*	6*	6**	6	6*
6**	6*	–	6***	6*	6*	6*	6**	6	6*
6**	6*	–	6***	6*	6*	6*	6**	6	6*
3*	3*				3*			3	



ATTENTION
Bulbs for Navigation Lights
The bulbs used in Navigation Lights are part of the approval/certification.
Bulbs which are non-approved null-invoid your insurance cover as your lights will not be in line with the regulations/certification.
We recommend to use approved material only since this is in the interest of your safety.

ACHTUNG
Glühlampen für Navigationslaternen
Die in Navigationslaternen verwendeten Glühlampen sind Teil der Zulassung.
Reserveglühlampen müssen ebenfalls zugelassen sein. Im Versicherungsfall riskieren Sie den Verlust Ihrer Versicherungsdeckung wenn sich herausstellt, daß Ihre Ausrüstung nicht den Vorschriften entspricht.
Wir empfehlen im Interesse Ihrer Sicherheit nur zugelassenes Material zu verwenden.

- 1 for all vessels of less than 7 m
- 2 for all vessels of less than 12 m
- 3 for all vessels of less than 20 m
- 4 for all vessels of less than 50 m
- 5 for power driven vessels > 20 - < 50 m
- 6 for power driven vessels of 20 m and above
- 7 for power driven vessels < 12 m
- 8 navigation lights for recreational boating need no national approval
- 9 approval pending

- * type approval, no individual certificates
- ** individual certificates (see remarks)
- *** one certificate per supply
- **** type approval for recreational, no individual certificate

Official individual certificates, issued by government authorities are available from Italy, Peoples Republic of China and Russia.
Where required works certificates or copies of approval documents may be issued.

- 1 für alle Wasserfahrzeuge kleiner als 7 m
- 2 für alle Wasserfahrzeuge kleiner als 12 m
- 3 für alle Wasserfahrzeuge kleiner als 20 m
- 4 für alle Wasserfahrzeuge kleiner als 50 m
- 5 für motorbetriebene Wasserfahrzeuge > 20 - < 50 m
- 6 für motorbetriebene Wasserfahrzeuge von 20 m und darüber
- 7 für motorbetriebene Wasserfahrzeuge < 12 m
- 8 Navigationslaternen der Sportschifffahrt, die keine nationale Zulassung benötigen
- 9 in Bearbeitung

- * Typenzulassung, keine Einzelzertifikate
- ** Einzelzertifikate (siehe Hinweis)
- *** 1 Zertifikat pro Lieferung
- **** Typenzulassung für die Sportschifffahrt, keine Einzelzertifikate

Offizielle Einzelzertifikate, ausgestellt von den dazu autorisierten Regierungsstellen, gibt es nur für die Länder, Italien, Volksrepublik China und Russland.
Die Kosten für diese Zertifikate sind Veränderungen unterworfen und wo erforderlich, können Werkszertifikate oder Kopien von Zulassungszeugnissen bestellt werden.