

# OWNER'S GUIDE &

# INSTALLATION INSTRUCTIONS

## Thru-Hull: Retractable *with* Valve Tilted Element™ Transducer Tilt Angles: 0°, 12°, 20°

Models: DT800V-0°, DT800V-12°, DT800V-20°

U.S. Patent 7,369,458. U.K. Patent 2 414 077

06/09/14  
17-431-01 rev. 07

**Follow the precautions below for optimal product performance and to reduce the risk of property damage, personal injury, and/or death.**

**WARNING:** Always wear safety goggles and a dust mask when installing.

**WARNING:** The **YELLOW** O-ring must be in place near the top of the insert to make a watertight seal.

**WARNING:** To retrofit the insert in a housing *without* a valve, the insert must have a **BLACK** O-ring near the top to make a watertight seal.

**WARNING:** The O-rings must be intact and well lubricated to make a watertight seal.

**WARNING:** The valve is not a watertight seal! Be sure the insert or blanking plug is fully inserted into the housing, and the cap nut is screwed on completely.

**WARNING:** Always attach the safety wire to prevent the insert or blanking plug from backing out in the unlikely event that the cap nut fails or is screwed on incorrectly.

**WARNING:** Immediately check for leaks when the boat is placed in the water. Do not leave the boat unchecked for more than three hours. Even a small leak may allow considerable water to accumulate.

**WARNING: Stainless steel housing in a metal hull—**Be sure the washer contacts the hull. Do not tighten the hull nut with the washer against the isolation bushing, as the housing will not be firmly installed.

**CAUTION: Plastic housing—**Never use a fairing with a plastic housing; the protruding sensor would be vulnerable to damage from impact.

**CAUTION: Metal housing—**Never install a metal housing in a vessel with a positive ground system.

**CAUTION:** Never pull, carry, or hold the transducer by its cable; this may sever internal connections.

**CAUTION:** The arrow on the top of the transducer must point toward the keel or centerline of the boat. This will align the angle of the element inside the transducer with the deadrise angle of your hull.

**CAUTION: Stainless steel housing in a metal hull—**The stainless steel housing must be isolated from a metal hull to prevent electrolytic corrosion. Use the isolation bushing supplied.

**CAUTION:** Never use solvents. Cleaner, fuel, sealant, paint, and other products may contain solvents that can damage plastic parts, especially the transducer's face.

**IMPORTANT:** Read the instructions completely before proceeding with the installation. These instructions supersede any other instructions in your instrument manual if they differ.

Record the information found on the cable tag for future reference.

Part No. \_\_\_\_\_ Date \_\_\_\_\_ Frequency \_\_\_\_\_ kHz

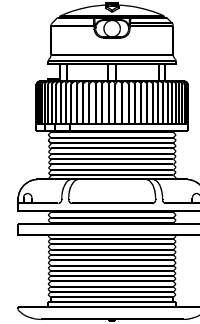

## Applications

- **Plastic** housing recommended for fiberglass or metal hull only. *Never install a plastic housing in a wood hull since swelling of the wood can fracture the plastic.*
- **Bronze** housing recommended for fiberglass or wood hull. *Never install a bronze housing in an aluminum hull because electrolytic corrosion will occur.*
- **Stainless steel** housing compatible with all hull materials. Recommended for aluminum hulls to prevent electrolytic corrosion *provided the stainless steel housing is isolated from the metal hull.*

## Match Tilt Angle of Transducer to Deadrise

Be sure your transducer model matches the deadrise angle of your boat at the mounting location. See the top of the transducer insert for the tilt angle (see Figure 1). To measure the deadrise angle of your hull at the selected mounting location, use an angle finder or a digital level (see Figure 2).

- 0° model for deadrise angles from 0° to 7°
- 12° model for deadrise angles from 8° to 15°
- 20° model for deadrise angles from 16° to 24°

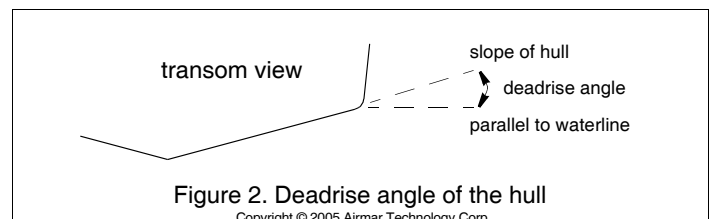
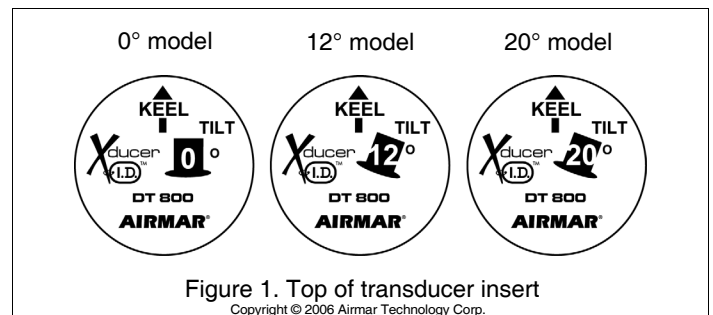

## Tools & Materials

Safety goggles  
 Dust mask  
 Electric drill with 10mm (3/8") or larger chuck capacity  
 Drill bit: 3mm or 1/8"  
 Hole saw: 51 mm or 2" (plastic or metal housing in non-metal hull)  
 57 mm or 2-1/4" (stainless steel housing in a metal hull)

Sandpaper  
 Mild household detergent or weak solvent (such as alcohol)  
 File (installation in a metal hull)  
 Marine sealant (suitable for below waterline)  
 Slip-joint pliers (installing a metal housing)  
 Grommet(s) (some installations)  
 Cable ties  
 Water-based anti-fouling paint (**mandatory in salt water**)  
 Installation in a cored fiberglass hull (see page 3):  
 Hole saw for hull interior: 60mm or 2-3/8"  
 Fiberglass cloth and resin  
 or Cylinder, wax, tape, and casting epoxy

## Mounting Location

**CAUTION:** Do not mount in line with or near water intake or discharge openings or behind strakes, fittings, or hull irregularities that may disturb the water flow.

**CAUTION:** Do not mount the sensor where the boat may be supported during trailering, launching, hauling, or storage to avoid damaging the transducer's face.

- The water flowing under the hull must be smooth with a minimum of bubbles and turbulence (especially at high speeds).
- The transducer must be continuously immersed in water.
- The transducer beam must be unobstructed by the keel or propeller shaft(s).
- Choose a location away from interference caused by power and radiation sources such as: the propeller(s) and shaft(s), other machinery, other echosounders, and other cables. The lower the noise level, the higher the echosounder gain setting that can be used.
- Choose an accessible spot inside the vessel with adequate headroom for the height of the housing, tightening the nuts, and removing the insert. Allow a minimum of 280mm (11").

### Boat Types (see Figure 3)

- **Displacement hull powerboats**—Locate amidships near the centerline. The starboard side of the hull where the propeller blades are moving downward is preferred.
- **Planing hull powerboats**—Mount well aft, on or near the centerline, and *well inboard of the first set of lifting strakes* to ensure that the transducer will be in contact with the water at high speeds. The starboard side of the hull where the propeller blades are moving downward is preferred.
- **Outboard and I/O**—Mount just forward of the engine(s).
- **Inboard**—Mount well ahead of the propeller(s) and shaft(s).
- **Stepped hull**—Mount just ahead of the first step.
- **Boat capable of speeds above 25kn (29MPH)**—Review the installation location and operating results of similar boats before proceeding.
- **Fin keel sailboats**—Mount on or near the centerline and forward of the fin keel 300–600mm (1–2').
- **Full keel sailboats**—Locate amidships and away from the keel.

## Anti-fouling Paint

Surfaces exposed to salt water must be coated with anti-fouling paint. *Use water-based anti-fouling paint only.* Never use ketone-based paint, since ketones can attack many plastics possibly damaging the transducer.

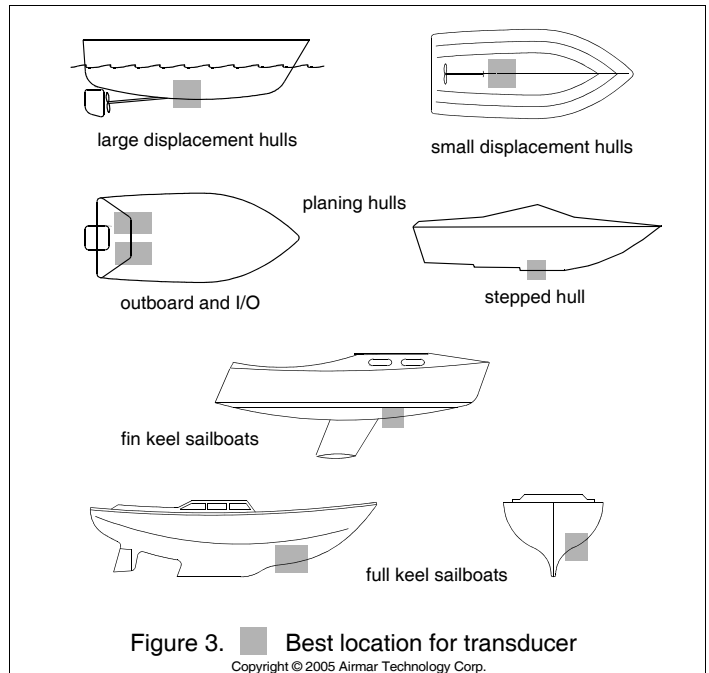

It is easier to apply paint before installation, but allow sufficient drying time. Reapply paint every 6 months or at the beginning of each boating season. Paint the following surfaces (see Figure 4):

- Outside wall of the insert
- Exposed end of the insert
- Exterior flange of the housing
- Bore of the housing up 30mm (1-1/4")
- Blanking plug below the lower O-ring including the exposed end

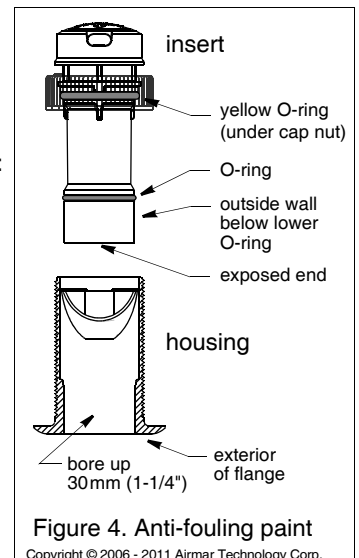

## Installation

### Hole Drilling

**Cored fiberglass hull**—Follow separate instructions on page 3.

1. Drill a 3mm or 1/8" pilot hole from inside the hull. If there is a rib, strut or other hull irregularity near the selected mounting location, drill from the outside.
  2. Using the appropriate size hole saw, cut a hole perpendicular to the hull from outside the boat.
  3. Sand and clean the area around the hole, inside and outside, to ensure that the sealant will adhere properly to the hull. If there is any petroleum residue inside the hull, remove it with either mild household detergent or a weak solvent (alcohol) before sanding.
- Metal hull**—Remove all burrs with a file and sandpaper.

### Bedding

**CAUTION:** Be sure the surfaces to be bedded are clean and dry.

Apply a 2mm (1/16") thick layer of marine sealant around the flange of the housing that will contact the hull and up the sidewall of the housing (see Figure 5). The sealant must extend 6mm (1/4") higher than the combined thickness of the hull, the washer, and the hull nut. This will ensure there is sealant in the threads to seal the hull and to hold the hull nut securely in place.

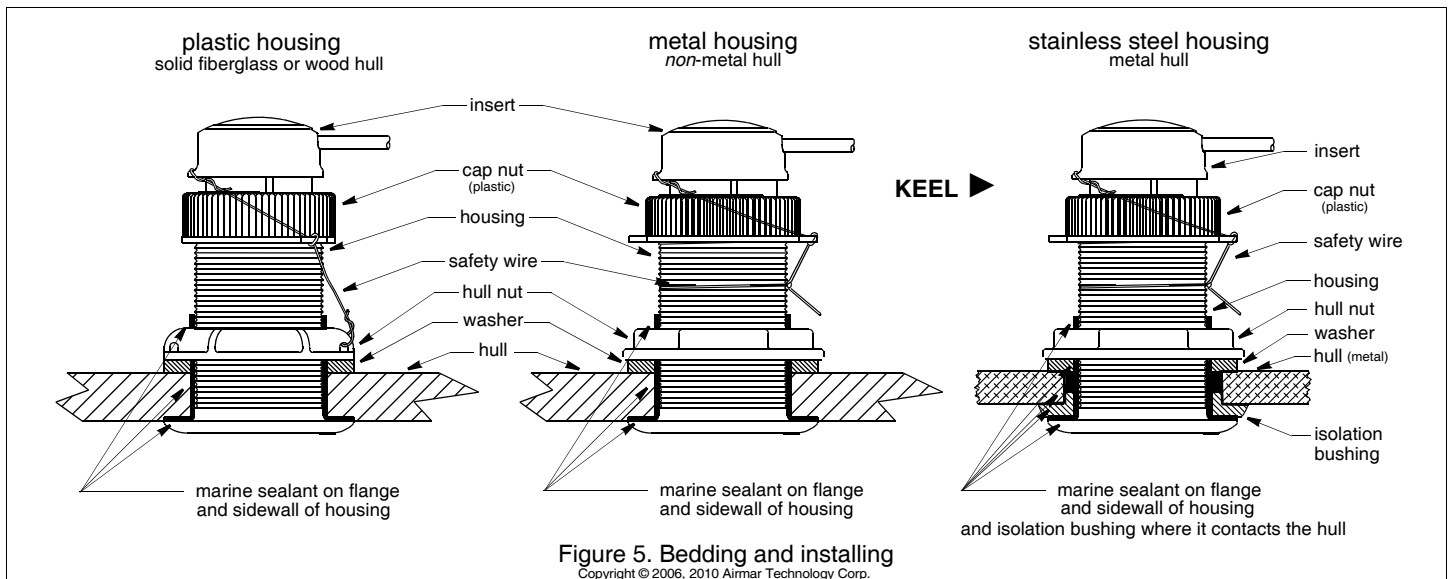

Figure 5. Bedding and installing  
Copyright © 2006, 2010 Airmar Technology Corp.

**Stainless steel housing in a metal hull**—To prevent electrolytic corrosion, the stainless steel housing must be isolated from the metal hull. Slide the isolation bushing onto the housing. Apply *additional* sealant to the surfaces of the isolation bushing that will contact the hull, filling any cavities in and around the bushing.

### Installing

**NOTE:** Disregard any arrow on the housing; it is not used.

1. From outside the hull, push the housing into the mounting hole using a twisting motion to squeeze out excess sealant.
2. From inside the hull, slide the washer onto the housing (see Figure 5).

**Stainless steel housing in a metal hull**—Be sure the washer contacts the hull. Do not tighten the hull nut with the washer against the isolation bushing, as the housing will not be firmly installed. If necessary, sand the isolation bushing until the washer rests against the hull.

3. Screw the hull nut in place.

**Plastic hull nut**—**Hand-tighten** only. Do not over tighten.

**Metal hull nut**—Tighten with slip-joint pliers.

**Cored fiberglass hull**—Do not over tighten, crushing the hull.

**Wood hull**—Allow the wood to swell before tightening the hull nut.

4. Remove any excess marine sealant on the outside of the hull to ensure smooth water flow under the transducer.
5. After the marine sealant cures, inspect the O-rings on the insert (replace if necessary) and lubricate them with the silicone lubricant supplied (see Figure 4). Be sure the **YELLOW** O-ring is in place near the top. O-rings must be intact and well lubricated to make a watertight seal. Also lubricate the bore of the housing above the valve.
6. **Slide the insert into the housing with the arrow on the top pointing toward the KEEL or centerline of the boat** (see Figure 1). Be sure the insert is fully inserted.
7. Screw the cap nut several turns until the threads are engaged. Being sure the arrow on the top of the insert and the cable exit are pointing toward the keel/centerline, continue to tighten the cap nut completely. Be careful not to rotate the housing and disturb the sealant. **Hand tighten** only. Do not over tighten.
8. Attach the safety wire to prevent the insert from backing out in the unlikely event that the cap nut fails or is screwed on incorrectly (see Figure 5).

**Plastic housing**—Attach the safety wire to one eye in the hull nut. Keeping the wire taut throughout, lead the wire in a counterclockwise direction and thread it through one eye in the

cap nut. Thread the wire through the eye a second time. Then lead the wire through the eye in the insert. Twist the wire securely to itself.

**Metal housing**—Wrap one end of the safety wire tightly around the housing and twist it together with the long end. Keeping the wire taut throughout, lead the wire straight up and through one eye in the cap nut. Thread the wire through the eye a second time. Then lead the wire counterclockwise and through the eye in the insert. Twist the wire securely to itself.

### Installing in Housing *WITHOUT* Valve

To create a watertight seal in a housing that does NOT have a valve, the insert must have a **BLACK** O-ring near the top. Use Replacement O-ring Kit 20-519-01 and follow the instructions supplied.

### Cable Routing & Connecting

**CAUTION:** If your transducer came with a connector, do not remove it to ease cable routing. If the cable must be cut and spliced, use Airmar's splash-proof Junction Box No. 33-035 and follow the instructions provided. Removing the waterproof connector or cutting the cable, except when using a watertight junction box, will void the transducer warranty.

1. Route the cable to the instrument being careful not to tear the cable jacket when passing it through the bulkhead(s) and other parts of the boat. Use grommets to prevent chaffing. To reduce electrical interference, separate the transducer cable from other electrical wiring and the engine. Coil any excess cable and secure it in place with cable ties to prevent damage.
2. Refer to the instrument owner's manual to connect the transducer to the instrument.

### Checking for Leaks

When the boat is placed in the water, **immediately** check around the thru-hull transducer for leaks. Note that very small leaks may not be readily observed. Do not leave the boat in the water for more than 3 hours before checking it again. If there is a small leak, there may be considerable bilge water accumulation after 24 hours. If a leak is observed, repeat "Bedding" and "Installing" **immediately** (see page 2).

## Installation in a Cored Fiberglass Hull

The core (wood or foam) must be cut and sealed carefully. The core must be protected from water seepage, and the hull must be reinforced to prevent it from crushing under the hull nut allowing the housing to become loose.

**CAUTION:** Completely seal the hull to prevent water seepage into the core.

1. Drill a 3mm or 1/8" pilot hole from inside the hull. If there is a rib, strut, or other hull irregularity near the selected mounting location, drill from the outside. (If the hole is drilled in the wrong location, drill a second hole in a better location. Apply masking tape to the outside of the hull over the incorrect hole and fill it with epoxy.)
2. Using a 51 mm or 2" hole saw, cut the hole from outside the hull through the *outer* skin only (see Figure 6).
3. From inside the hull using a 60 mm or 2-3/8" hole saw, cut through the *inner* skin and most of the core. The core material can be very soft. Apply only light pressure to the hole saw after cutting through the inner skin to avoid accidentally cutting the *outer* skin.
4. Remove the plug of core material so the *inside* of the outer skin and the inner core of the hull are fully exposed. Sand and clean the inner skin, core, and the outer skin around the hole.
5. If you are skilled with fiberglass, saturate a layer of fiberglass cloth with a suitable resin and lay it inside the hole to seal and strengthen the core. Add layers until the hole is the correct diameter. Alternatively, a hollow or solid cylinder of the correct diameter can be coated with wax and taped in place. Fill the gap between the cylinder and hull with casting epoxy. After the epoxy has set, remove the cylinder.
6. Sand and clean the area around the hole, inside and outside, to ensure that the marine sealant will adhere properly to the hull. If there is any petroleum residue inside the hull, remove it with either mild household detergent or a weak solvent (alcohol) before sanding.
7. Proceed with "Bedding" on page 2.

## Operation & Maintenance

### How the Valve Works

**The valve is not a watertight seal!** The transducer incorporates a self-closing valve which minimizes the flow of water into the boat when the insert is removed. The curved flap valve is activated by both a spring and water pressure. Water pushes the flap valve upward to block the opening, so there is no gush of water into the boat. Always use the insert or the blanking plug secured with the safety wire for a watertight seal.

### Using the Blanking Plug

To protect the insert, use the blanking plug:

- When the boat will be kept in salt water for more than a week.
  - When the boat will be removed from the water.
  - When aquatic growth buildup on the insert is suspected due to inaccurate readings from the instrument.
1. The O-rings must be intact and well lubricated to make a watertight seal. On the blanking plug, inspect the O-rings (replace if necessary) and lubricate them with the silicone lubricant supplied or petroleum jelly (Vaseline®) (see Figure 7).
  2. Remove the insert from the housing by removing the safety wire and unscrewing the cap nut (see Figure 5). This will jack out the insert. Grasp the insert and remove it with a slow pulling motion. Slide the blanking plug into the housing. Be sure the blanking plug is fully inserted. Screw the cap nut several turns until the threads are engaged. Continue to tighten the cap nut completely. **Hand tighten only.** Do not over tighten.
 

**NOTE:** In the very unlikely event that the valve breaks, replace the housing the next time the boat is hauled.
  3. Reattach the safety wire to prevent the blanking plug from backing out in the unlikely event that the cap nut fails or is screwed on incorrectly.

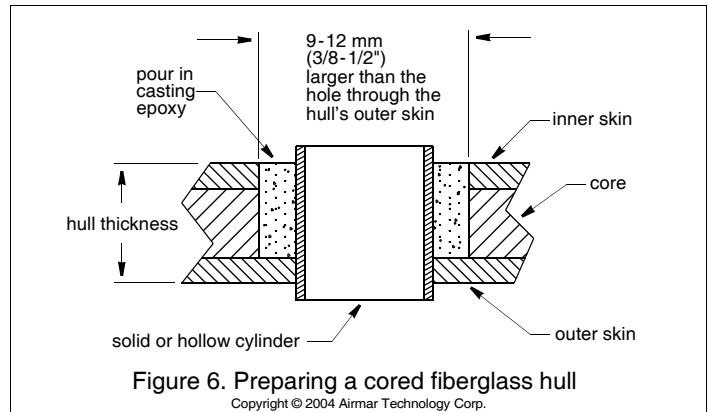

Figure 6. Preparing a cored fiberglass hull

Copyright © 2004 Airmar Technology Corp.

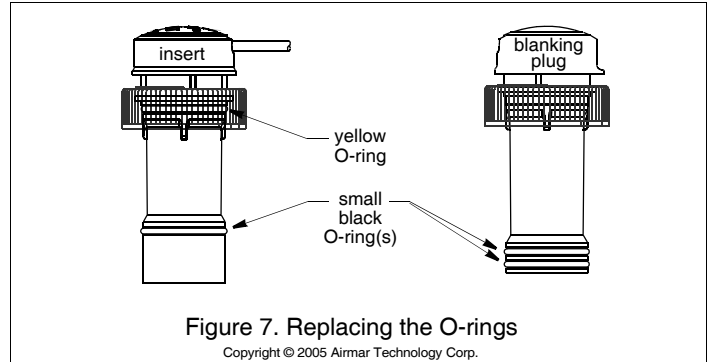

Figure 7. Replacing the O-rings

Copyright © 2005 Airmar Technology Corp.

### Cleaning the Insert

Aquatic growth can accumulate rapidly on the depth transducer's face reducing performance within weeks. Clean the insert with a Scotch-Brite® scour pad and mild household detergent, being careful to avoid making scratches. If fouling is severe, lightly wet sand it with fine grade wet/dry paper.

### Winterizing

After the boat has been hauled for winter storage, remove the blanking plug to let the water drain away before reinserting it. This will prevent any water from freezing around the blanking plug and possibly cracking it.

### Replacement Transducer & Parts

The information needed to order a replacement Airmar transducer is printed on the cable tag. Do not remove this tag. When ordering, specify the part number, date, and frequency in kHz. For convenient reference, record this information on the top of page one.

Lost, broken, or worn parts should be replaced immediately. If you have purchased a plastic housing and have a wood hull or desire greater strength, purchase an Airmar metal housing.

Blanking Plug	Hull Nut	Washer	Housing with Valve, Hull Nut, and Washer
33-538-01	04-004 (plastic) 02-030 (bronze) 02-530-02 (stainless steel)	09-452	33-510-01 (plastic, P617V) 33-588-01 (bronze, B617V) 33-617-01 (stainless steel, SS617V)

Obtain parts from your instrument manufacturer or marine dealer.

Gemeco  
(USA)

Tel: 803.693.0777  
Fax: 803.693.0477  
email: sales@gemeco.com  
Tel: +33.(0)2.23.52.06.48  
Fax: +33.(0)2.23.52.06.49  
email: sales@airmar-emea.com

Airmar EMEA  
(Europe, Middle East, Africa)



35 Meadowbrook Drive, Milford, New Hampshire 03055-4613, USA

•www.airmar.com