

ACM100

Alternating Current Monitor

User's Manual

Revision 1.0

Copyright © 2008 Maretron, LLP All Rights Reserved

Maretron, LLP
9014 N. 23rd Ave #10
Phoenix, AZ 85021-7850
<http://www.maretron.com>

Maretron Manual Part #: M001701

Revision History

Revision	Description
1.0	Original document

Table of Contents

1	Introduction	1
1.1	Firmware Revision	1
1.2	ACM100 Features	1
1.3	Quick Install	1
2	Installation	2
2.1	Unpacking the Box	2
2.2	Choosing a Mounting Location	2
2.3	Mounting the ACM100	3
2.4	Connecting the ACM100	3
2.4.1	NMEA 2000® Connection	3
2.4.2	AC Sensor Connections	4
2.4.2.1	Single-Phase (Phase A) Connection	5
2.4.2.2	Single-Phase (Phase A, B) Connection	6
2.4.2.3	Three-Phase (Phase A, B, C) Connection	8
2.4.3	Checking Connections	10
2.5	Configuring the ACM100	10
2.5.1	Device Instance	10
2.5.2	AC Device Type	10
2.5.3	AC Circuit Type	11
2.5.4	Reset Total Energy Recorded	11
2.5.5	Advanced Configuration	11
2.5.5.1	Device Priority	11
2.5.5.2	V,I,F Damping Period	11
2.5.5.3	Power Damping Period	11
2.5.5.4	Current Transformer A	11
2.5.5.5	Current Transformer B	12
2.5.5.6	Current Transformer C	12
2.5.6	NMEA 2000® PGN Enable/Disable	12
2.5.7	Restore Factory Defaults	12
3	Output Parameters	12
	Line-	13
3.1	Specific and Line-to-Neutral Measurements	13
3.2	Line-to-Line Measurements	13
4	Maintenance	13
5	Troubleshooting	14
6	Technical Specifications	15
7	Technical Support	16
8	Installation Template	17
9	Maretron (2 Year) Limited Warranty	18

Table of Figures

Figure 1	– Mounting the ACM100	3
Figure 2	– NMEA 2000® Connector Face Views	4

Figure 3 – Single-Phase (Single Line) Connection Diagram..... 5
Figure 4 – Single-Phase (Dual Line) Connection Diagram 6
Figure 5 – Three-Phase Connection Diagram 8
Figure 6 – Mounting Surface Template 17

Table of Appendices

Appendix A – NMEA 2000® Interfacing..... A1

1 Introduction

Congratulations on your purchase of the Maretron Alternating Current (AC) Monitor (ACM100). Maretron has designed and built your ACM100 to the highest standards for years of dependable and accurate service.

Maretron's ACM100 is a device which monitors AC power sources and outputs information about these sources onto the industry standard NMEA 2000® marine data network. ACM100 output information is then displayed with networked NMEA 2000® equipment such as the Maretron DSM250 dedicated display or with NMEA 2000® compatible software such as Maretron N2KView.

The Maretron ACM100 is designed to operate within the harsh demands of the marine environment. However, no piece of marine electronic equipment can function properly unless installed, configured, and maintained in the correct manner. Please read carefully and follow these instructions for installation, configuration, and usage of the Maretron ACM100 in order to ensure optimal performance.

1.1 Firmware Revision

This manual corresponds to ACM100 firmware revision 1.0.0.

1.2 ACM100 Features

The Maretron ACM100 has the following features.

- NMEA 2000® Interface
- Waterproof Connectors
- Sealed Waterproof Enclosure
- Opto-Isolated from NMEA 2000® Eliminating Potential Ground Loops
- Monitoring of busses carrying AC power and transmitting
 - Voltage
 - Frequency
- Monitoring AC Power Sources such as Utilities and Generators and transmitting:
 - Voltage
 - Current
 - Frequency
 - Real Power
 - Reactive Power
 - Apparent Power
 - Power Factor
 - Total Energy Imported
 - Total Energy Exported

1.3 Quick Install

Installing the Maretron ACM100 involves the following five steps. Please refer to the individual sections for additional details.

1. Unpack the box (Section 2.1)
2. Choose a mounting location (Section 2.2)
3. Mount the ACM100 (Section 2.3)
4. Connect the ACM100 (Section 0)
5. Configure the ACM100 (Section 2.5)

2 Installation

2.1 Unpacking the Box

When unpacking the box containing the Maretron ACM100, you should find the following items:

- 1 – ACM100 – AC Monitor
- 1 – AC Current Sensor with 5 ft. (1.5m) long cable (Part # PCT-1000-101-03)
- 1 – Parts Bag containing 4 Stainless Steel Mounting Screws
- 1 – ACM100 User's Manual
- 1 – Warranty Registration Card

If any of these items are missing or damaged, please contact Maretron.

2.2 Choosing a Mounting Location

Please consider the following when choosing a mounting location.

1. The ACM100 is waterproof, so it can be mounted in a damp or dry location.
2. The orientation is not important, so the ACM100 can be mounted on a horizontal deck, vertical bulkhead, or upside down if desired.
3. The ACM100 is temperature rated to 55°C (130°F), so it should be mounted away from engines or engine rooms where the operating temperature exceeds the specified limit.

2.3 Mounting the ACM100

Attach the ACM100 securely to the vessel using the included stainless steel mounting screws or other fasteners as shown in Figure 1 below.

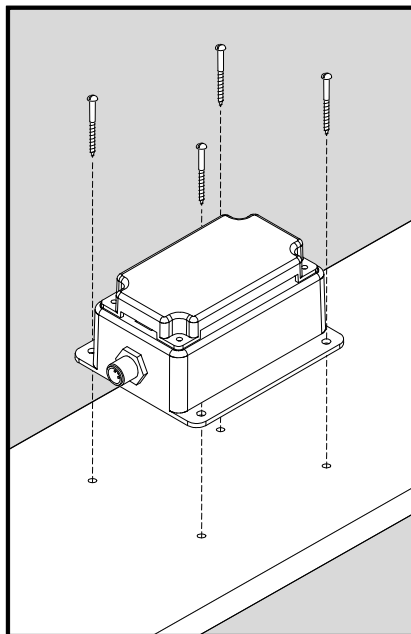

Figure 1 – Mounting the ACM100

2.4 Connecting the ACM100

The ACM100 requires two types of electrical connections: 1) the NMEA 2000® connection (refer to Section 2.4.1), and 2) the AC sensor connections (i.e., current sensor(s) and sensing voltage(s) connections), which are described in Section 2.4.2.

2.4.1 NMEA 2000® Connection

The NMEA 2000® connector can be found on the side of the enclosure. The NMEA 2000® connector is a round five pin male connector (see Figure 2). You connect the ACM100 to an NMEA 2000® network using a Maretron NMEA 2000® cable (or compatible cable) by connecting the female end of the cable to the ACM100 (note the key on the male connector and keyway on the female connector). Be sure the cable is connected securely and that the collar on the cable connector is tightened firmly. Connect the other end of the cable (male) to the NMEA 2000® network in the same manner. The ACM100 is designed such that you can plug or unplug it from an NMEA 2000® network while the power to the network is connected or disconnected. Please follow recommended practices for installing NMEA 2000® network products.

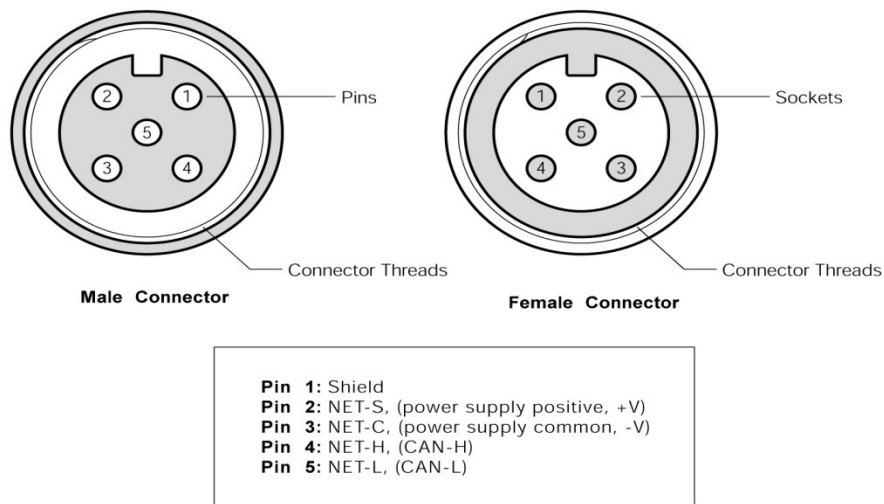

Figure 2 – NMEA 2000® Connector Face Views

2.4.2 AC Sensor Connections

The ACM100 sensor connections are made by connecting to the 12-pin terminal strip on the top of the unit. First, remove the four screws at the corners of the unit detaching the splash guard from the unit. On the bottom of the splash guard, you will find a label detailing the wire connection to pin number assignments, which are repeated in the table below.

Pin #	Signal Name	Connection
1	$V_{A\text{Line}}$	Voltage Phase A Line
2	$V_{B\text{Line}}$	Voltage Phase B Line
3	$V_{C\text{Line}}$	Voltage Phase C Line
4	$V_{A\text{Neutral}}$	Voltage Phase A Neutral
5	$V_{B\text{Neutral}}$	Voltage Phase B Neutral
6	$V_{C\text{Neutral}}$	Voltage Phase C Neutral
7	I_{A+}	Current Phase A Plus
8	I_{A-}	Current Phase A Minus
9	I_{B+}	Current Phase B Plus
10	I_{B-}	Current Phase B Minus
11	I_{C+}	Current Phase C Plus
12	I_{C-}	Current Phase C Minus



WARNING: The voltages present on AC circuits can cause electrocution. Before making any electrical connections to the ACM100, ensure that power is removed from all AC circuits that will be connected to the ACM100. Only restore AC power after all connections have been made to the ACM100 and the splash guard has been re-installed.



WARNING: If the supplied current transformer is placed around a wire carrying AC current, then extremely high voltages can develop on the output leads of the current transformer, with severe risk of electrocution. For safety, keep the output leads of the current transformer(s) shorted or tied together until they are connected to the proper terminals on the ACM100.



WARNING: User supplied voltage sense cables must be 18 gauge or larger, have insulation rated to 600V, and must have the conductor connected to the hot lead of the AC power source protected by a fuse rated at 3A or less (the current consumed by the voltage sense circuit on the ACM100 is negligible, at less than 10mA).

Before attempting to connect the ACM100 to the AC source, determine the type of system you will be monitoring. The ACM100 supports the connection and monitoring of three different system types; 1) single-phase single line system (Section 2.4.2.1), or 2) single-phase dual line system (Section 2.4.2.2), or 3) three-phase system (Section 2.4.2.3).

2.4.2.1 Single-Phase (Phase A) Connection

Please refer to Figure 3 for connecting the ACM100 to a single phase, single line system.

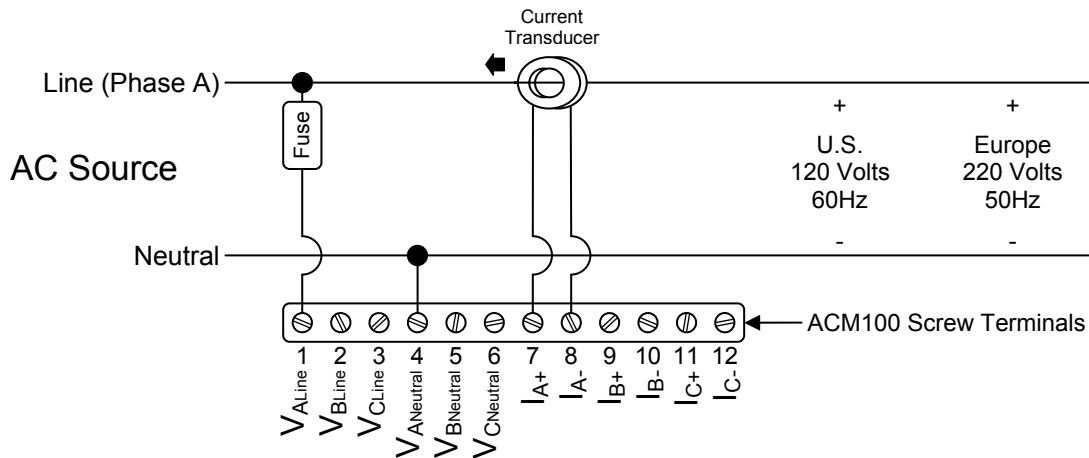

Figure 3 – Single-Phase (Single Line) Connection Diagram

Use the following instructions when you are connecting the ACM100 to a single-phase circuit connected via one (hot) phase wire and one neutral wire. You will need to install one current transformer and one voltage sense cable.

Step 1: De-energize the AC Source.

Step 2: The Current Transformer has black and white wires. Install the Current Transformer as follows:

- a. Connect the black wire to pin 7 (I_{A+}) on the ACM100
- b. Connect the white wire to pin 8 (I_{A-}) on the ACM100
- c. Disconnect the hot wire from the AC power source and place it through the hole in the Current Sensor such that the arrow on the Current Sensor points *towards* the AC power source. Then, reattach the hot wire to the AC source.

Step 3: You must supply a cable for connecting the voltage sense pins on the ACM100 to the AC source. For the purposes of these instructions, we will assume that the cable has one black conductor and one white conductor. Install the voltage sense cable as follows:

- a. Connect the white wire from one end of the Voltage Sense cable to pin 4 ($V_{ANeutral}$) on the ACM100.
- b. Connect the white wire from the other end of the Voltage Sense cable to the neutral wire of the AC source being monitored.
- c. Connect the black wire from one end of the Voltage Sense cable to pin 1 (V_{ALine}) on the ACM100
- d. Connect the black wire from the other end of the Voltage Sense cable to a fuse appropriately sized for the black wire (18 gauge wire minimum and 3 amp fuse or less).
- e. Connect the other end of the fuse to the AC source hot wire (the fuse should be placed within 6 inches of the connection to the hot wire).

2.4.2.2 Single-Phase (Phase A, B) Connection

Please refer to Figure 4 for connecting the ACM100 to a single phase, dual line system.

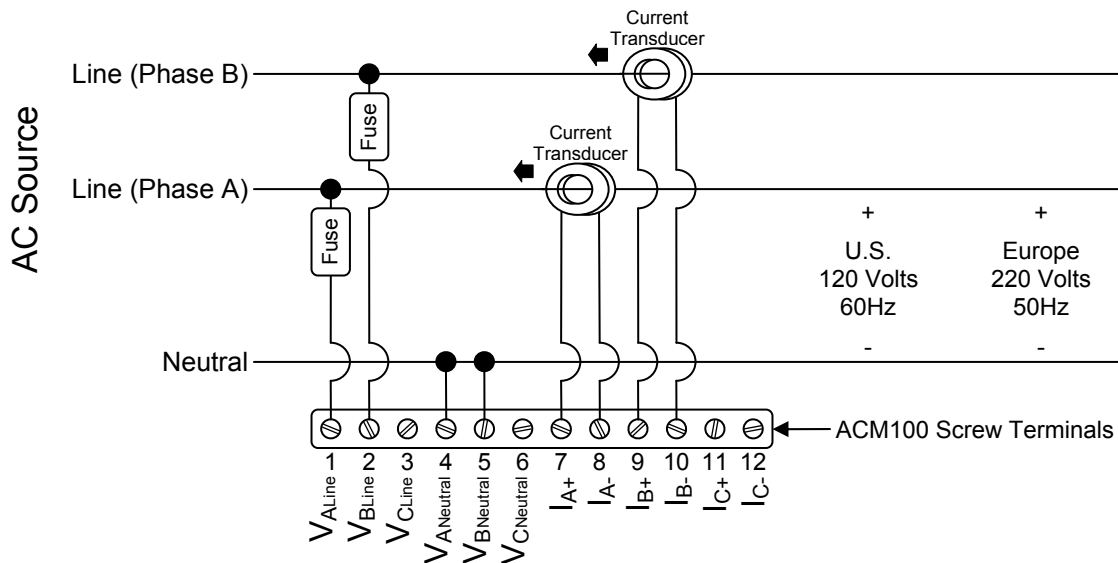

Figure 4 – Single-Phase (Dual Line) Connection Diagram

Use the following instructions when you are connecting the ACM100 to a single-phase circuit connected via two hot wires. You will need to install two current transformer and two user-supplied voltage sense cables. The ACM100 comes with a single current transformer so you

will need to purchase an optional current sensor (Part # PCT-1000-101-03) for monitoring this type of system.

Step 1: De-energize the AC Source.

Step 2: The Current Transformer has black and white wires. Install the Phase A Current Transformer as follows:

- a. Connect the black wire to pin 7 (I_{A+}) on the ACM100
- b. Connect the white wire to pin 8 (I_{A-}) on the ACM100
- c. Disconnect the Phase A hot wire from the AC power source and place it through the hole in the Current Sensor such that the arrow on the Current Sensor points *towards* the AC power source. Then, reattach the hot wire to the AC power source.

Step 3: Repeat step 2 for the Phase B Current Transformer as follows:

- a. Connect the black wire to pin 9 (I_{B+}) on the ACM100
- b. Connect the white wire to pin 10 (I_{B-}) on the ACM100
- c. Disconnect the Phase B hot wire from the AC power source and place it through the hole in the Current Sensor such that the arrow on the Current Sensor points *towards* the AC power source. Then, reattach the hot wire to the AC power source.

Step 4: You must supply cables for connecting the voltage sense pins on the ACM100 to the AC source. For the purposes of these instructions, we will assume that each cable has one black conductor and one white conductor. Install the first voltage sense cable as follows:

- a. Connect the white wire from one end of the first Voltage Sense cable to pin 4 ($V_{ANeutral}$) on the ACM100.
- b. Connect the white wire from the other end of the first Voltage Sense cable to the neutral wire of the AC source being monitored
- c. Connect the black wire from one end of the first Voltage Sense cable to pin 1 (V_{ALine}) on the ACM100
- d. Connect the black wire from the other end of the first Voltage Sense cable to a fuse appropriately sized for the black wire (18 gauge wire minimum and 3 amp fuse or less).
- e. Connect the other end of the fuse to the AC source hot wire (the fuse should be placed within 6 inches of the connection to the hot wire).

Step 5: Install the second Voltage Sense cable as follows:

- a. Connect the white wire from one end of the second Voltage Sense cable to pin 5 ($V_{BNeutral}$) on the ACM100.
- b. Connect the white wire from the other end of the second Voltage Sense cable to the neutral wire of the AC source being monitored.
- c. Connect the black wire from one end of the second Voltage Sense cable to pin 2 (V_{BLine}) on the ACM100
- d. Connect the black wire from the other end of the second Voltage Sense cable to a fuse appropriately sized for the black wire (18 gauge wire minimum and 3 amp fuse or less).
- e. Connect the other end of the fuse to the AC source hot wire (the fuse should be placed within 6 inches of the connection to the hot wire).

2.4.2.3 Three-Phase (Phase A, B, C) Connection

Please refer to Figure 5 for connecting the ACM100 to a three phase system.

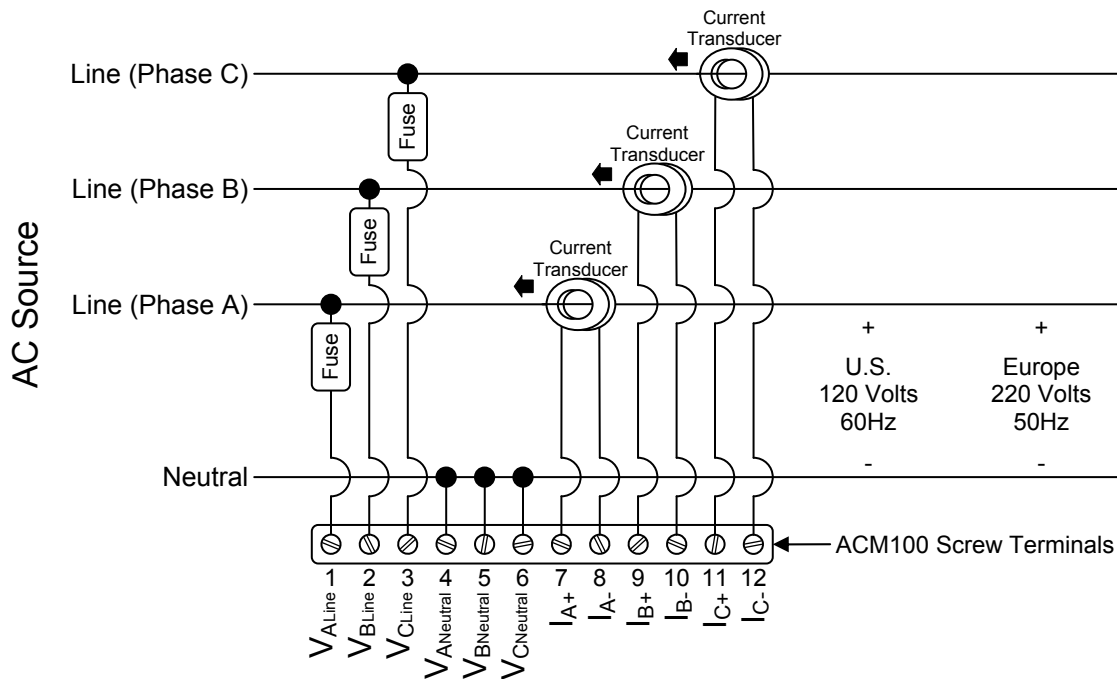

Figure 5 – Three-Phase Connection Diagram

Use the following instructions when you are connecting the ACM100 to a three-phase “Wye” circuit connected via three hot wires and a single neutral (NOTE: Three-phase delta connected circuits are not supported by the ACM100). You will need to install three current transformers and three user-supplied voltage sense cables. The ACM100 comes with a single current transformer so you will need to purchase two optional current sensors (Part # PCT-1000-101-03) for monitoring this type of system.

Step 1: De-energize the AC Source.

Step 2: The Current Transformer has black and white wires. Install the first Current Transformer as follows:

- Connect the black wire to pin 7 (I_{A+}) on the ACM100
- Connect the white wire to pin 8 (I_{A-}) on the ACM100
- Disconnect the Phase A hot wire from the AC power source and place it through the hole in the Current Sensor such that the arrow on the Current Sensor points *towards* the AC power source. Then, reattach the Phase A hot wire to the AC power source.

Step 3: Install the second Current Transformer as follows:

- Connect the black wire to pin 9 (I_{B+}) on the ACM100
- Connect the white wire to pin 10 (I_{B-}) on the ACM100

- c. Disconnect the Phase B hot wire from the AC power source and place it through the hole in the Current Sensor such that the arrow on the Current Sensor points *towards* the AC power source. Then, reattach the Phase B hot wire to the AC power source.

Step 4: Install the third Current Transformer as follows:

- a. Connect the black wire to pin 11 (I_{C+}) on the ACM100
- b. Connect the white wire to pin 12 (I_{C-}) on the ACM100
- c. Disconnect the Phase C hot wire from the AC power source and place it through the hole in the Current Sensor such that the arrow on the Current Sensor points *towards* the AC power source. Then, reattach the Phase C hot wire to the AC power source.

Step 5: You must supply a cable for connecting the voltage sense pins on the ACM100 to the AC source. For the purposes of these instructions, we will assume that the cable has one black conductor and one white conductor. Install the voltage sense cable as follows:

- a. Connect the white wire from one end of the Voltage Sense cable to pin 4 ($V_{ANeutral}$) on the ACM100.
- b. Connect the white wire from the other end of the Voltage Sense cable to the neutral wire of the AC source being monitored.
- c. Connect the black wire from one end of the Voltage Sense cable to pin 1 (V_{ALine}) on the ACM100
- d. Connect the black wire from the other end of the Voltage Sense cable to a fuse appropriately sized for the black wire (18 gauge wire minimum and 3 amp fuse or less).
- e. Connect the other end of the fuse to the AC source hot wire (the fuse should be placed within 6 inches of the connection to the hot wire).

Step 6: Install the second Voltage Sense cable as follows:

- a. Connect the white wire from one end of the second Voltage Sense cable to pin 5 ($V_{BNeutral}$) on the ACM100.
- b. Connect the white wire from the other end of the second Voltage Sense cable to the neutral wire of the AC source being monitored.
- c. Connect the black wire from one end of the second Voltage Sense cable to pin 2 (V_{BLine}) on the ACM100
- d. Connect the black wire from the other end of the second Voltage Sense cable to a fuse appropriately sized for the black wire (18 gauge wire minimum and 3 amp fuse or less).
- e. Connect the other end of the fuse to the AC source hot wire (the fuse should be placed within 6 inches of the connection to the hot wire).

Step 7: Install the third Voltage Sense cable as follows:

- a. Connect the white wire from one end of the second Voltage Sense cable to pin 6 ($V_{CNeutral}$) on the ACM100.
- b. Connect the white wire from the other end of the second Voltage Sense cable to the neutral wire of the AC source being monitored.

- c. Connect the black wire from one end of the second Voltage Sense cable to pin 3 (V_{CLine}) on the ACM100
- d. Connect the black wire from the other end of the second Voltage Sense cable to a fuse appropriately sized for the black wire (18 gauge wire minimum and 3 amp fuse or less).
- e. Connect the other end of the fuse to the AC source hot wire (the fuse should be placed within 6 inches of the connection to the hot wire).

2.4.3 Checking Connections

Once the NMEA 2000[®] connection, Current Sensor(s), and Voltage Sense connection(s) to the ACM100 have been completed, restore power to the monitored AC source and check to see that information is being properly transmitted by observing an appropriate NMEA 2000[®] display. If you don't see AC power data, refer to Section 5, "Troubleshooting".

2.5 Configuring the ACM100

The ACM100 will transmit data over the NMEA 2000 network as it is shipped from the factory; however, it may require configuration, depending on the type of AC source being monitored. There are several configurable items within the ACM100, which are detailed in the remainder of this section.

You configure the ACM100 using a Maretron DSM250 display or other NMEA 2000[®] display unit that is capable of configuring the ACM100. Please refer to the Maretron *DSM250 User's Manual* for details.

2.5.1 Device Instance

NMEA 2000[®] provides a unique AC power instance for each AC power source on a vessel. This value should be programmed in each ACM100 so that each ACM100 is associated with a unique device instance number. The default instance number is 0, which is used to indicate the first ACM100 that is hooked to the network. Subsequent ACM100s connected to the network would be numbered 1, 2, and so on.

2.5.2 AC Device Type

You must configure the ACM100 as to what type of AC source it is monitoring. The allowable values for this parameter are as follows:

- "Generator" (default) – use this value when you are monitoring the output of a genset.
- "Utility" – use this value when you are monitoring shore power
- "Bus" – use this value if you are monitoring power flowing across a cable that is not located directly at the output of a genset or a shore power connection (e.g., an AC selection switch might have as an input the shore power and another input from the genset, connecting the ACM100 at the output of the AC selection switch would require the ACM100 to be configured as "Bus").

2.5.3 AC Circuit Type

You must configure the ACM100 as to what type of AC circuit connection it is monitoring. The allowable values for this parameter are as follows:

- Single-Phase (Phase A) – use this value when power is connected via a single hot wire and a single neutral wire (a typical 110VAC connection in the US).
- Single-Phase (Phase A, B) – use this value when power is connected via the two hot wires and single neutral wire from a single phase of a transformer (a typical 220VAC connection in the US).
- Three-Phase (Phase A, B, C) – use this value when power is connected via the three hot wires and single neutral wire from a three-phase “Wye” connected circuit.

2.5.4 Reset Total Energy Recorded

The ACM100 accumulates the total energy imported from a Utility and exported from a generator. Select this option to zero the total energy accumulated readings in the ACM100.

2.5.5 Advanced Configuration...

Certain parameters do not normally need to be set in order for normal operation, but are included in an advanced configuration section for use in special situations.

2.5.5.1 Device Priority

If you have only one ACM100 on a particular AC power source, you should leave the priority selection at the default value of 0. However, NMEA 2000® can provide a unique priority for allowing multiple, redundant sensors for a single AC power source on a vessel. Redundant sensors for a single AC power source should have the same device instance number and different priority selections. If you have redundant sensors on a single AC power source, you should leave the primary sensor at its default priority value of 0, and program the secondary sensor with a priority value of 1.

2.5.5.2 V,I,F Damping Period

If you feel that the monitored Voltage, Current, and Frequency parameters are changing too quickly or too slowly on the display, you can adjust the damping that is applied to the output readings by adjusting this parameter. The default damping period is 0.5 seconds. You may change it to a value in the range of 0.2 seconds to 10 seconds.

2.5.5.3 Power Damping Period

If you feel that the monitored Power parameters are changing too quickly or too slowly on the display, you can adjust the damping that is applied to the output readings by adjusting this parameter. The default damping period is 5 seconds. You may change it to a value in the range of 0.2 seconds to 10 seconds.

2.5.5.4 Current Transformer A

If you notice that the current of phase A is negative when it should be positive, or vice-versa, then the current transformer has been installed backwards. If this happens, then instead of

reconnecting the current transformer, you may change the value of this parameter from the default value of “Normal Install” to “Inverse Install” to correct for this.

2.5.5.5 Current Transformer B

If you notice that the current of phase B is negative when it should be positive, or vice-versa, then the current transformer has been installed backwards. If this happens, then instead of reconnecting the current transformer, you may change the value of this parameter from the default value of “Normal Install” to “Inverse Install” to correct for this.

2.5.5.6 Current Transformer C

If you notice that the current of phase C is negative when it should be positive, or vice-versa, then the current transformer has been installed backwards. If this happens, then instead of reconnecting the current transformer, you may change the value of this parameter from the default value of “Normal Install” to “Inverse Install” to correct for this.

2.5.6 NMEA 2000[®] PGN Enable/Disable

The ACM100 is capable of transmitting many different kinds of NMEA 2000[®] messages (or PGNs) associated with AC power sources. You may individually enable or disable each of these messages. You may also change the rate of transmission of each of these messages if desired.

2.5.7 Restore Factory Defaults

Selecting this configuration option causes all stored parameters in the ACM100 to be reset to the values they contained when the unit was manufactured.

3 Output Parameters

The ACM100 outputs a variety of information about the AC power source onto the NMEA 2000 network. The tables below detail which measurements are made available on the bus for the different combinations of different AC source types and circuit types which may be selected.

3.1 Line-Specific and Line-to-Neutral Measurements

Parameter	AC Source Type			Available Data			
	Bus	Generator	Utility	Average	Phase A	Phase B	Phase C
Line-Neutral AC RMS Voltage	✓	✓	✓	✓	✓	✓ ¹	✓ ²
AC RMS Current		✓	✓	✓	✓	✓ ¹	✓ ²
AC Frequency	✓	✓	✓	✓	✓	✓ ¹	✓ ²
Real Power		✓	✓	✓	✓	✓ ¹	✓ ²
Apparent Power		✓	✓	✓	✓	✓ ¹	✓ ²
Reactive Power		✓	✓	✓	✓	✓ ¹	✓ ²
Power Factor		✓	✓	✓	✓	✓ ¹	✓ ²
Total kW Hours Export		✓	✓	✓			
Total kW Hours Import		✓	✓	✓			

Notes:

1. Available only if circuit type has been set to “Single-Phase (Phase A,B)” or “Three-Phase (Phase A,B,C)”
2. Available only if circuit type has been set to “Three-Phase (Phase A,B,C)”

3.2 Line-to-Line Measurements

Parameter	AC Source Type			Available Data			
	Bus	Generator	Utility	Average	Phase A to Phase B	Phase B to Phase C	Phase C to Phase A
Line-Line AC RMS Voltage	✓	✓	✓	✓	✓ ¹	✓ ²	✓ ²

Notes:

1. Available only if circuit type has been set to “Single-Phase (Phase A,B)” or “Three-Phase (Phase A,B,C)”
2. Available only if circuit type has been set to “Three-Phase (Phase A,B,C)”

4 Maintenance

Regular maintenance is important to ensure continued proper operation of the Maretron ACM100. Perform the following tasks periodically:

- Clean the unit with a soft cloth. Do not use chemical cleaners as they may remove paint or markings or may corrode the ACM100 enclosure or seals.
- Ensure that the unit is mounted securely and cannot be moved relative to the mounting surface. If the unit is loose, tighten the mounting screws.
- Check the security of the cable connected to the NMEA 2000[®] connector, and tighten if necessary.
- Check the security of all of the current sensor connections and voltage sensor connections on the top of the unit and tighten if necessary.

5 Troubleshooting

If you notice unexpected operation of the Maretron ACM100, follow the troubleshooting procedures in this section to remedy simple problems. If these steps do not solve your problem, please contact Maretron Technical Support (refer to Section 7 for contact information).

Symptom	Troubleshooting Procedure
No AC power data visible on NMEA 2000 [®] network.	Ensure that the ACM100 is properly connected to the NMEA 2000 [®] network. Ensure that the current transformers and voltage sense cables are properly connected to the ACM100. Ensure that the ACM100 has the appropriate NMEA 2000 [®] PGNs enabled as described in Section 2.5.6.
Exported power is increasing when it shouldn't be Imported power is not increasing when it should be Currents are showing as negative values when they should be showing as positive values	The current transformer(s) are installed backwards. Either 1) reinstall the current transformers in the opposite direction or 2) configure the ACM100 to recognize the reversed installation as described in Sections 2.5.5.4, 2.5.5.5, and 2.5.5.6.
Power readings are not what I expect	Please review carefully the installation instructions in Section 0 and the configuration of the circuit type in Section 2.5.3.

6 Technical Specifications

As Maretron is constantly improving its products, all specifications are subject to change without notice. Maretron products are designed to be accurate and reliable; however, they should be used only as aids to navigation and not as a replacement for traditional navigation aids and techniques.

Certifications

Parameter	Comment
NMEA 2000®	Level A
Maritime Navigation and Radiocommunication Equipment & Systems	IEC 60945
FCC and CE Mark	Electromagnetic Compatibility

NMEA 2000® Parameter Group Numbers (PGNs)

Description	PGN #	PGN Name	Default Rate
Periodic Data PGNs	65001	Bus #1 Phase C Basic AC Quantities	10 times/second
	65002	Bus #1 Phase B Basic AC Quantities	10 times/second
	65003	Bus #1 Phase A Basic AC Quantities	10 times/second
	65004	Bus #1 Average Basic AC Quantities	10 times/second
	65005	Utility Total AC Energy	10 times/second
	65006	Utility Phase C AC Reactive Power	10 times/second
	65007	Utility Phase C AC Power	10 times/second
	65008	Utility Phase C AC Basic Quantities	10 times/second
	65009	Utility Phase B AC Reactive Power	10 times/second
	65010	Utility Phase B AC Power	10 times/second
	65011	Utility Phase B AC Basic Quantities	10 times/second
	65012	Utility Phase A AC Reactive Power	10 times/second
	65013	Utility Phase A AC Power	10 times/second
	65014	Utility Phase A AC Basic Quantities	10 times/second
	65015	Utility Total AC Reactive Power	10 times/second
	65016	Utility Total AC Power	10 times/second
	65017	Utility Average Basic AC Quantities	10 times/second
	65018	Generator Total AC Energy	10 times/second
	65019	Generator Phase C AC Reactive Power	10 times/second
	65020	Generator Phase C AC Power	10 times/second
	65021	Generator Phase C AC Basic Quantities	10 times/second
	65022	Generator Phase B AC Reactive Power	10 times/second
	65023	Generator Phase B AC Power	10 times/second
	65024	Generator Phase B AC Basic Quantities	10 times/second
	65025	Generator Phase A AC Reactive Power	10 times/second
	65026	Generator Phase A AC Power	10 times/second
	65027	Generator Phase A AC Basic Quantities	10 times/second
	65028	Generator Total AC Reactive Power	10 times/second
	65029	Generator Total AC Power	10 times/second
		65030	Generator Average Basic AC Quantities
Response to Requested PGNs	126464	PGN List (Transmit and Receive)	N/A
	126996	Product Information	N/A
	126998	Configuration Information	N/A
Protocol PGNs	059392	ISO Acknowledge	N/A
	059904	ISO Request	N/A
	060928	ISO Address Claim	N/A
	065240	ISO Address Command	N/A
	126208	NMEA	N/A
Maretron Proprietary PGNs	128720	Configuration	N/A

Electrical

Parameter	Value	Comment
Operating Voltage	5 to 36 Volts	DC Voltage
Power Consumption	100 mA	NMEA 2000 [®] Interface
Load Equivalence Number (LEN)	2	NMEA 2000 [®] Spec. (1LEN = 50 mA)
Reverse Battery Protection	Yes	Indefinitely
Load Dump Protection	Yes	Energy Rated per SAE J1113

Mechanical

Parameter	Value	Comment
Size	3.50" x 4.20" x 2.03" (88.9mm x 106.7mm x 51.6mm)	Including Flanges for Mounting
Weight	13 oz. (368.5 g)	

Environmental

Parameter	Value
IEC 60954 Classification	Exposed
Degree of Protection	IP64
Operating Temperature	-25°C to 55°C
Storage Temperature	-40°C to 70°C
Relative Humidity	93%RH @40° per IEC60945-8.2
Vibration	2-13.2Hz @ ±1mm, 13.2-100Hz @ 7m/s ² per IEC 60945-8.7
Solar Radiation	Ultraviolet B, A, Visible, and Infrared per IEC 60945-8.10
Corrosion (Salt Mist)	4 times 7days @ 40°C, 95%RH after 2 hour Salt Spray Per IEC 60945-8.12
Electromagnetic Emission	Conducted and Radiated Emission per IEC 60945-9
Electromagnetic Immunity	Conducted, Radiated, Supply, and ESD per IEC 60945-10
Safety Precautions	Dangerous Voltage, Electromagnetic Radio Frequency per IEC 60945-12

7 Technical Support

If you require technical support for Maretron products, you can reach us in any of the following ways:

Telephone: 1-866-550-9100
Fax: 1-602-861-1777
E-mail: support@maretron.com
World Wide Web: <http://www.maretron.com>
Mail: Maretron, LLC
Attn: Technical Support
9014 N. 23rd Ave Suite 10
Phoenix, AZ 85021 USA

8 Installation Template

Please check the dimensions before using the following diagram as a template for drilling the mounting holes because the printing process may have distorted the dimensions.

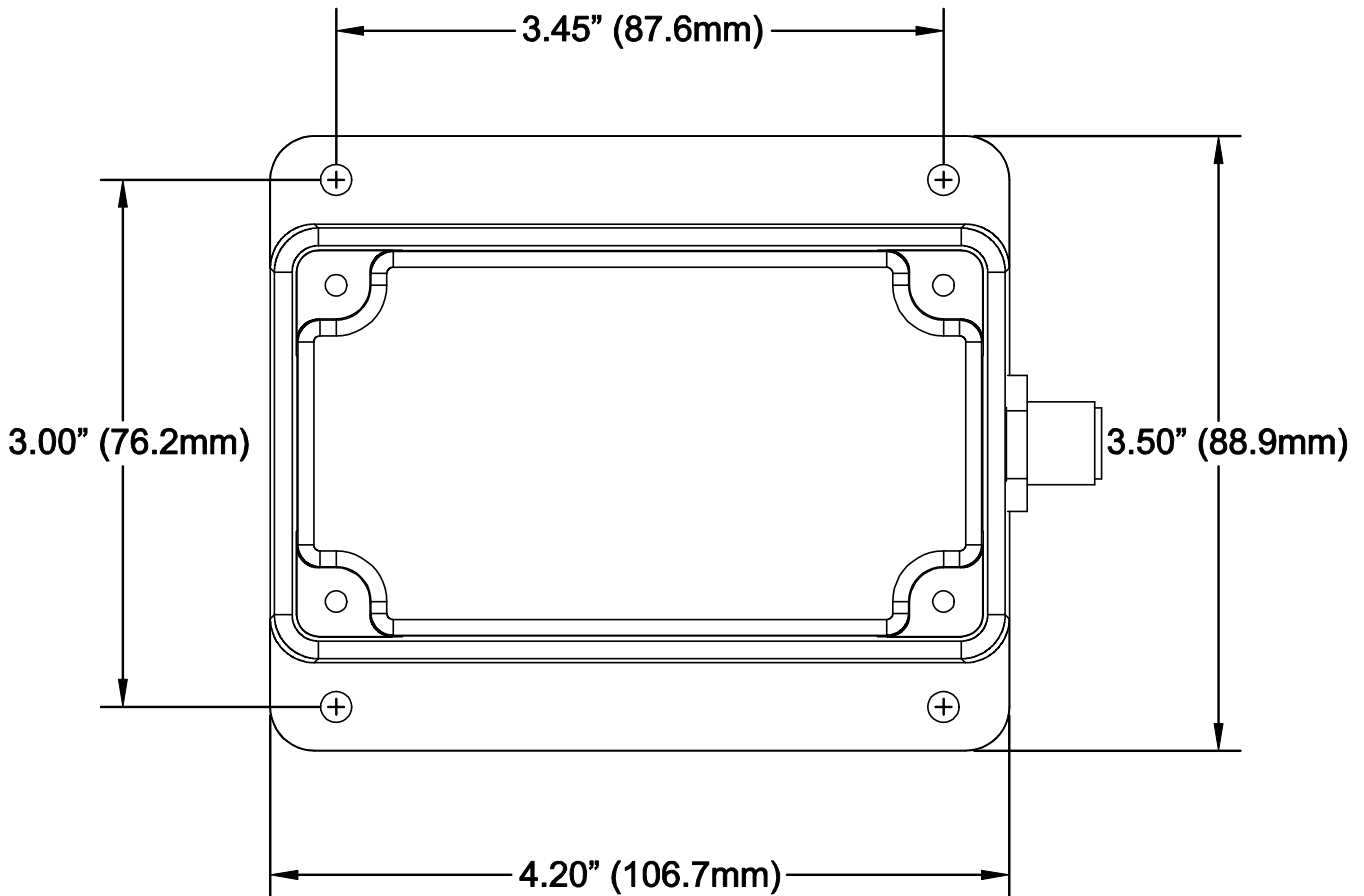

Figure 6 – Mounting Surface Template

9 Maretron (2 Year) Limited Warranty

Maretron warrants the ACM100 to be free from defects in materials and workmanship for **two (2) years** from the date of original purchase. If within the applicable period any such products shall be proved to Maretron's satisfaction to fail to meet the above limited warranty, such products shall be repaired or replaced at Maretron's option. Purchaser's exclusive remedy and Maretron's sole obligation hereunder, provided product is returned pursuant to the return requirements below, shall be limited to the repair or replacement, at Maretron's option, of any product not meeting the above limited warranty and which is returned to Maretron; or if Maretron is unable to deliver a replacement that is free from defects in materials or workmanship, Purchaser's payment for such product will be refunded. Maretron assumes no liability whatsoever for expenses of removing any defective product or part or for installing the repaired product or part or a replacement therefore or for any loss or damage to equipment in connection with which Maretron's products or parts shall be used. With respect to products not manufactured by Maretron, Maretron's warranty obligation shall in all respects conform to and be limited to the warranty actually extended to Maretron by its supplier. The foregoing warranties shall not apply with respect to products subjected to negligence, misuse, misapplication, accident, damages by circumstances beyond Maretron's control, to improper installation, operation, maintenance, or storage, or to other than normal use or service.

THE FOREGOING WARRANTIES ARE EXPRESSLY IN LIEU OF AND EXCLUDES ALL OTHER EXPRESS OR IMPLIED WARRANTIES, INCLUDING BUT NOT LIMITED TO THE IMPLIED WARRANTIES OF MERCHANTABILITY AND OF FITNESS FOR A PARTICULAR PURPOSE.

Statements made by any person, including representatives of Maretron, which are inconsistent or in conflict with the terms of this Limited Warranty, shall not be binding upon Maretron unless reduced to writing and approved by an officer of Maretron.

IN NO CASE WILL MARETRON BE LIABLE FOR INCIDENTAL OR CONSEQUENTIAL DAMAGES, DAMAGES FOR LOSS OF USE, LOSS OF ANTICIPATED PROFITS OR SAVINGS, OR ANY OTHER LOSS INCURRED BECAUSE OF INTERRUPTION OF SERVICE. IN NO EVENT SHALL MARETRON'S AGGREGATE LIABILITY EXCEED THE PURCHASE PRICE OF THE PRODUCT(S) INVOLVED. MARETRON SHALL NOT BE SUBJECT TO ANY OTHER OBLIGATIONS OR LIABILITIES, WHETHER ARISING OUT OF BREACH OF CONTRACT OR WARRANTY, TORT (INCLUDING NEGLIGENCE), OR OTHER THEORIES OF LAW WITH RESPECT TO PRODUCTS SOLD OR SERVICES RENDERED BY MARETRON, OR ANY UNDERTAKINGS, ACTS OR OMISSIONS RELATING THERETO.

Maretron does not warrant that the functions contained in any software programs or products will meet purchaser's requirements or that the operation of the software programs or products will be uninterrupted or error free. Purchaser assumes responsibility for the selection of the software programs or products to achieve the intended results, and for the installation, use and results obtained from said programs or products. No specifications, samples, descriptions, or illustrations provided Maretron to Purchaser, whether directly, in trade literature, brochures or other documentation shall be construed as warranties of any kind, and any failure to conform with such specifications, samples, descriptions, or illustrations shall not constitute any breach of Maretron's limited warranty.

Warranty Return Procedure:

To apply for warranty claims, contact Maretron or one of its dealers to describe the problem and determine the appropriate course of action. If a return is necessary, place the product in its original packaging together with proof of purchase and send to an Authorized Maretron Service Location. You are responsible for all shipping and insurance charges. Maretron will return the replaced or repaired product with all shipping and handling prepaid except for requests requiring expedited shipping (i.e. overnight shipments). Failure to follow this warranty return procedure could result in the product's warranty becoming null and void.

Maretron reserves the right to modify or replace, at its sole discretion, without prior notification, the warranty listed above. To obtain a copy of the then current warranty policy, please go to the following web page:

<http://www.maretron.com/company/warranty.php>

Appendix A – NMEA 2000® Interfacing

ACM100 NMEA 2000® Periodic Data Transmitted PGNs

PGN 65001 – Bus #1 Phase C Basic AC Quantities
PGN 65002 – Bus #1 Phase B Basic AC Quantities
PGN 65003 – Bus #1 Phase A Basic AC Quantities
PGN 65004 – Bus #1 Average Basic AC Quantities
PGN 65008 – Utility Phase C Basic AC Quantities
PGN 65011 – Utility Phase B Basic AC Quantities
PGN 65014 – Utility Phase A Basic AC Quantities
PGN 65017 – Utility Average Basic AC Quantities
PGN 65021 – Generator Phase C Basic AC Quantities
PGN 65024 – Generator Phase B Basic AC Quantities
PGN 65027 – Generator Phase A Basic AC Quantities
PGN 65030 – Generator Average Basic AC Quantities

The ACM100 uses these PGN to transmit voltage, frequency, and current information

- Field 1: Line-Line AC RMS Voltage – This field indicates the AC RMS voltage between this phase and the next phase in units of 1 V.
- 2: Line-Neutral AC RMS Voltage – This field indicates the AC RMS voltage between this phase and the neutral phase in units of 1 V.
- 3: AC Frequency – This field indicates the frequency of the AC voltage in units of 1/128 Hz.
- 4: AC RMS Current (not transmitted for the “Bus” AC Source Type) – This field indicates the current flowing through the specified phase in units of 1 A.

PGN 65006 – Utility Phase C AC Reactive Power
PGN 65009 – Utility Phase B AC Reactive Power
PGN 65012 – Utility Phase A AC Reactive Power
PGN 65015 – Utility Total AC Reactive Power
PGN 65019 – Generator Phase C AC Reactive Power
PGN 65022 – Generator Phase B AC Reactive Power
PGN 65025 – Generator Phase A AC Reactive Power
PGN 65028 – Generator Total AC Reactive Power

The ACM100 uses this PGN to transmit reactive power and power factor information.

- Field 1: Reactive Power – This field indicates the reactive power delivered by the source in units of 1 VAR.
- 2: Power Factor – This field indicates the magnitude of the power factor supplied by the source in units of 1/16384 (dimensionless).
- 3: Power Factor Lagging – This field indicates whether the specified power factor is lagging or leading.

ACM100 User's Manual

PGN 65005 – Utility Total AC Energy

PGN 65018 – Generator Total AC Energy

The ACM100 uses this PGN to transmit the total energy delivered by the power source.

- Field 1: Total kWh Hours Export – This field indicates the total energy delivered by the AC power source in units of 1 kWh.
2: Total kWh Hours Import – This field indicates the total energy delivered to the AC power source in units of 1 kWh.

PGN 65007 – Utility Phase C AC Power

PGN 65010 – Utility Phase B AC Power

PGN 65013 – Utility Phase A AC Power

PGN 65016 – Utility Total AC Power

PGN 65020 – Generator Phase C AC Power

PGN 65023 – Generator Phase B AC Power

PGN 65026 – Generator Phase A AC Power

PGN 65029 – Generator Total AC Power

The ACM100 uses these PGNs to transmit the total real power and apparent power (the vector sum of real power and reactive power).

- Field 1: Real Power – This field indicates the real power delivered by the AC power source in units of 1W.
2: Apparent Power – This field indicates the apparent power delivered by the AC power source in units of 1 VA.