

RIM100

Run Indicator Module

User's Manual

Revision 1.0

Copyright © 2008 Maretron, LLP All Rights Reserved

Maretron, LLP
9014 N. 23rd Ave #10
Phoenix, AZ 85021-7850
<http://www.maretron.com>

Maretron Manual Part #: M002001

Revision History

| Revision | Description |
|-----------------|--------------------|
| 1.0 | Original document |

Table of Contents

| | | |
|---------|--|----|
| 1 | Introduction | 1 |
| 1.1 | Firmware Revision | 1 |
| 1.2 | RIM100 Features | 1 |
| 1.3 | Quick Install | 1 |
| 2 | Installation | 2 |
| 2.1 | Unpacking the Box | 2 |
| 2.2 | Choosing a Mounting Location | 2 |
| 2.3 | Mounting the RIM100 | 3 |
| 2.4 | Connecting the RIM100 | 3 |
| 2.4.1 | NMEA 2000® Connection | 3 |
| 2.4.2 | Monitored Load Connections | 4 |
| 2.4.2.1 | AC Load | 5 |
| 2.4.2.2 | DC Load | 5 |
| 2.4.3 | Checking Connections | 6 |
| 2.5 | Configuring the RIM100 | 6 |
| 2.5.1 | Device Instance | 6 |
| 2.5.2 | Channel #1 - #6 Mode | 7 |
| 2.5.3 | Channel #1 - #6 Label | 7 |
| 2.5.4 | Advanced Configuration | 7 |
| 2.5.5 | NMEA 2000® PGN Enable/Disable | 7 |
| 2.5.6 | Restore Factory Defaults | 7 |
| 2.5.7 | Installation Description | 7 |
| 3 | Maintenance | 7 |
| 4 | Troubleshooting | 8 |
| 5 | Technical Specifications | 9 |
| 6 | Technical Support | 10 |
| 7 | Installation Template | 11 |
| 8 | Maretron (2 Year) Limited Warranty | 12 |

Table of Figures

| | | |
|----------|---|----|
| Figure 1 | – Mounting the RIM100 | 3 |
| Figure 2 | – NMEA 2000® Connector Face Views | 4 |
| Figure 3 | – AC Load Connection Diagram | 5 |
| Figure 4 | – DC Load Connection Diagram | 6 |
| Figure 5 | – Mounting Surface Template | 11 |

Table of Appendices

| | | |
|------------|--------------------------------|----|
| Appendix A | – NMEA 2000® Interfacing | A1 |
|------------|--------------------------------|----|

1 Introduction

Congratulations on your purchase of the Maretron Run Indicator Module (RIM100). Maretron has designed and built your RIM100 to the highest standards for years of dependable and accurate service.

Maretron's RIM100 monitors both AC and DC electrical circuits and reports, over an NMEA 2000® network, whether or not the electrical circuit is energized and running. The RIM100 works equally as well for monitoring manually switched loads (e.g., running lights, anchor lights, or deck lights) as it does for automatically switched loads. Monitoring automatically switched loads (e.g., bilge pumps, engine exhaust/intake fans, and transfer pumps) via the RIM100 is especially useful because you know exactly when equipment is, or isn't running.

The Maretron RIM100 is designed to operate within the harsh demands of the marine environment. However, no piece of marine electronic equipment can function properly unless installed, configured, and maintained in the correct manner. Please read carefully and follow these instructions for installation, configuration, and usage of the Maretron RIM100 in order to ensure optimal performance.

1.1 Firmware Revision

This manual corresponds to RIM100 firmware revision 1.0.2.

1.2 RIM100 Features

The Maretron RIM100 has the following features.

- NMEA 2000® Interface
- Waterproof Connectors
- Sealed Waterproof Enclosure
- Opto-Isolated from NMEA 2000® Eliminating Potential Ground Loops
- Monitors and reports the running status of connected devices
- Works with both AC and DC loads
- Works with both automatically and manually switched loads
- Can indicate the status of a wide variety of loads
 - Bilge Pumps
 - Winches
 - Running Lights
 - Transfer Pumps
 - Exhaust/Intake Fans

1.3 Quick Install

Installing the Maretron RIM100 involves the following five steps. Please refer to the individual sections for additional details.

1. Unpack the box (Section 2.1)
2. Choose a mounting location (Section 2.2)

3. Mount the RIM100 (Section 2.3)
4. Connect the RIM100 (Section 2.4)
5. Configure the RIM100 (Section 2.5)

2 Installation

2.1 Unpacking the Box

When unpacking the box containing the Maretron RIM100, you should find the following items:

- 1 – RIM100 – Run Indicator Module
- 1 – Parts Bag containing 4 Stainless Steel Mounting Screws
- 1 – RIM100 User's Manual
- 1 – Warranty Registration Card

If any of these items are missing or damaged, please contact Maretron.

2.2 Choosing a Mounting Location

Please consider the following when choosing a mounting location.

1. The RIM100 is waterproof, so it can be mounted in a damp or dry location.
2. The orientation is not important, so the RIM100 can be mounted on a horizontal deck, vertical bulkhead, or upside down if desired.
3. The RIM100 is temperature-rated to 55°C (130°F), so it should be mounted away from engines or engine rooms where the operating temperature exceeds the specified limit.

2.3 Mounting the RIM100

Attach the RIM100 securely to the vessel using the included stainless steel mounting screws or other fasteners as shown in Figure 1 below.

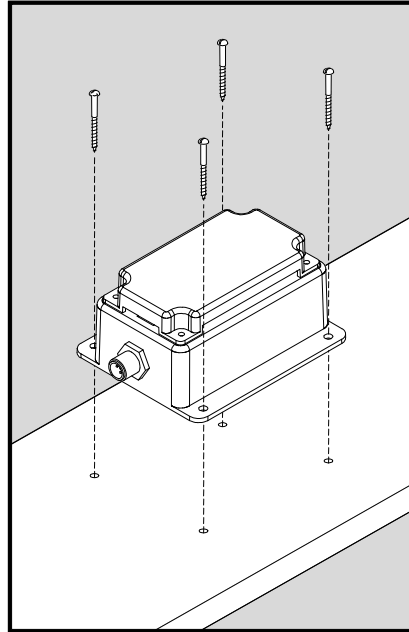

Figure 1 – Mounting the RIM100

2.4 Connecting the RIM100

The RIM100 requires two types of electrical connections: 1) the NMEA 2000® connection (refer to Section 2.4.1), and 2) the monitored load connections, which are described in Section 2.4.2.

2.4.1 NMEA 2000® Connection

The NMEA 2000® connector can be found on the side of the enclosure. The NMEA 2000® connector is a round five pin male connector (see Figure 2). You connect the RIM100 to an NMEA 2000® network using a Maretron NMEA 2000® cable (or compatible cable) by connecting the female end of the cable to the RIM100 (note the key on the male connector and keyway on the female connector). Be sure the cable is connected securely and that the collar on the cable connector is tightened firmly. Connect the other end of the cable (male) to the NMEA 2000® network in the same manner. The RIM100 is designed such that you can plug or unplug it from an NMEA 2000® network while the power to the network is connected or disconnected. Please follow recommended practices for installing NMEA 2000® network products.

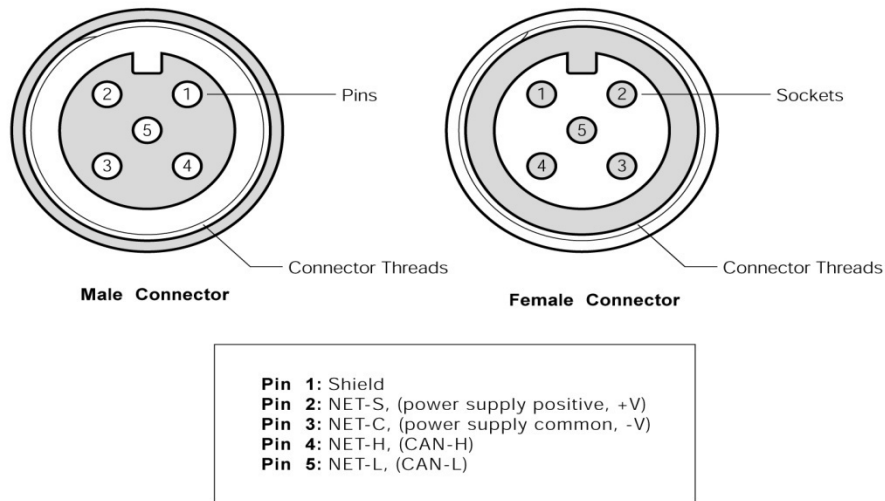

Figure 2 – NMEA 2000® Connector Face Views

2.4.2 Monitored Load Connections

The RIM100 monitored load connections are made by connecting to the 12-pin terminal strip on the top of the unit. First, remove the four screws at the corners of the unit detaching the splash guard from the unit. On the bottom of the splash guard, you will find a label detailing the wire connection to pin number assignments, which are repeated in the table below.

| Pin # | Signal Name | Connection |
|-------|-------------|---------------------------------------|
| 1 | V1+ | Voltage #1 (+ for DC monitored loads) |
| 2 | V1- | Voltage #1 (- for DC monitored loads) |
| 3 | V2+ | Voltage #2 (+ for DC monitored loads) |
| 4 | V2- | Voltage #2 (- for DC monitored loads) |
| 5 | V3+ | Voltage #3 (+ for DC monitored loads) |
| 6 | V3- | Voltage #3 (- for DC monitored loads) |
| 7 | V4+ | Voltage #4 (+ for DC monitored loads) |
| 8 | V4- | Voltage #4 (- for DC monitored loads) |
| 9 | V5+ | Voltage #5 (+ for DC monitored loads) |
| 10 | V5- | Voltage #5 (- for DC monitored loads) |
| 11 | V6+ | Voltage #6 (+ for DC monitored loads) |
| 12 | V6- | Voltage #6 (- for DC monitored loads) |

The RIM100 will detect the presence or absence of either AC or DC voltages. Before attempting to connect the RIM100 to the AC source, determine the type of system you will be monitoring. The RIM100 supports the connection and monitoring of two different system types; 1) AC loads (Section 2.4.2.1), or 2) DC loads (Section 2.4.2.2).



WARNING: The voltages present on AC circuits can cause electrocution. Before making any electrical connections to the RIM100, ensure that power is removed from all AC circuits that will be connected to the RIM100. Only restore AC power after all connections have been made to the RIM100 and the splash guard has been re-installed.



WARNING: User supplied voltage sense cables must be 18 gauge or larger, have insulation rated to 600V, and must have the conductor connected to the hot lead of the AC power source protected by a fuse rated at 3A or less (the current consumed by the voltage sense circuit on the RIM100 is negligible, at less than 10mA).

2.4.2.1 AC Load

Please refer to Figure 3 for connecting the RIM100 to an AC load. You may connect either terminal from the load to either terminal of the pair of terminals on the RIM100. This figure shows the connection of the monitored load to channel 1 via the terminals named V1+ and V1-. Connections to other channels are similar.

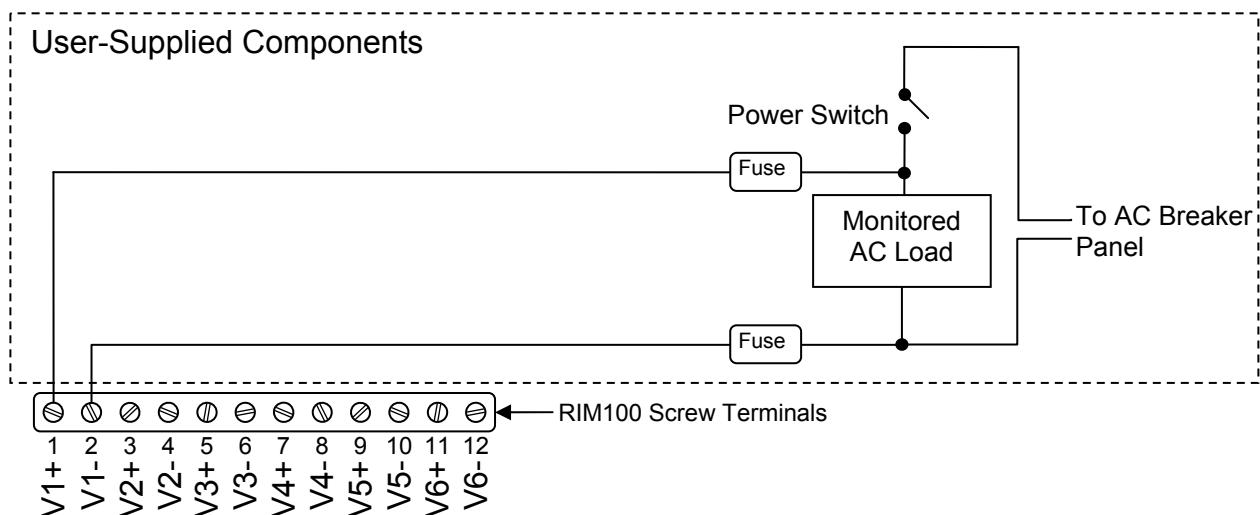

Figure 3 – AC Load Connection Diagram

2.4.2.2 DC Load

Please refer to Figure 4 for connecting the RIM100 to a DC load. Please note in this case that you must connect the positive voltage from the monitored load to the terminal marked “+” and the negative voltage from the monitored load to the terminal marked “-”. This figure shows the connection of the monitored load to channel 1 via the terminals named V1+ and V1-. Connections to other channels are similar.

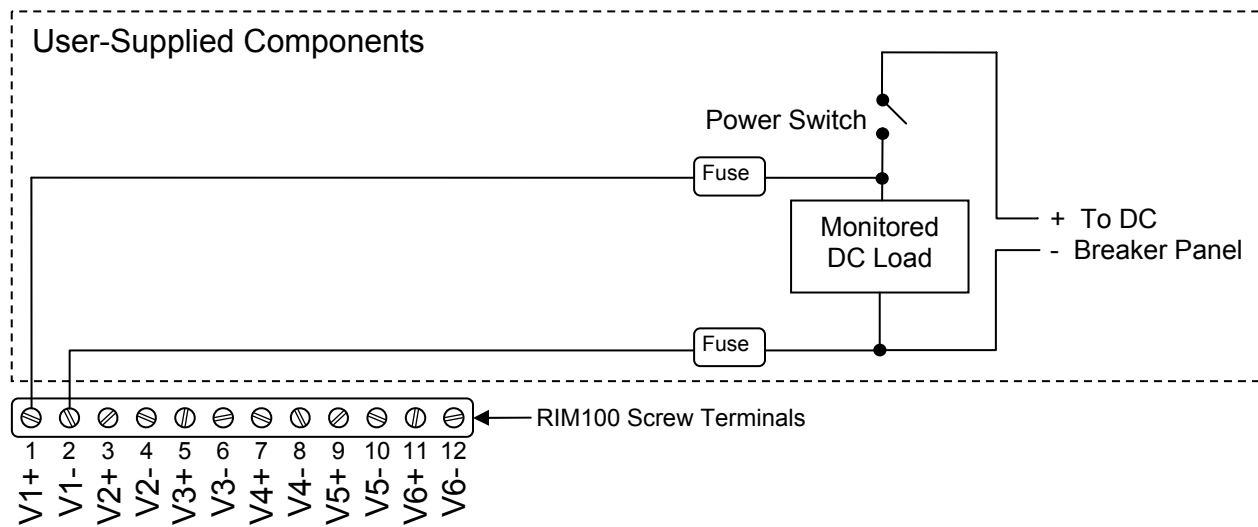

Figure 4 – DC Load Connection Diagram

2.4.3 Checking Connections

Once the NMEA 2000[®] connection and load connection(s) to the RIM100 have been completed, check to see that information is being properly transmitted by observing an appropriate NMEA 2000[®] display. If you don't see Run Indicator status, refer to Section 4, "Troubleshooting".

2.5 Configuring the RIM100

The RIM100 will transmit data over the NMEA 2000[®] network as it is shipped from the factory; however, it may require configuration, depending on how many loads are being monitored. There are several configurable items within the RIM100, which are detailed in the remainder of this section.

You configure the RIM100 using a Maretron DSM250 display or other NMEA 2000[®] display unit that is capable of configuring the RIM100. Please refer to the Maretron *DSM250 User's Manual* for details.

2.5.1 Device Instance

NMEA 2000[®] provides a unique device instance for each switch/run monitoring device on a vessel. This value should be programmed in each RIM100 so that each RIM100 is associated with a unique device instance number. The default instance number is 0, which is used to indicate the first RIM100 that is hooked to the network. Subsequent RIM100s connected to the network would be numbered 1, 2, and so on.

2.5.2 Channel #1 - #6 Mode

You must configure the RIM100 as to whether a particular channel should be enabled. The allowable values for this parameter are as follows:

- “Enable” (default) – Use this value if the channel is being used to monitor a load.
- “Disable” – Use this value if no load circuit is connected to the corresponding channel’s terminals. The RIM100 will indicate that no data is available for this circuit.

2.5.3 Channel #1 - #6 Label

Each channel that can be monitored by the RIM100 may be programmed with a text label that will be displayed in monitoring software and displays that recognize device labels, such as the Maretron N2KView Vessel Monitoring System and the Maretron DSM250 display. The label will let you assign an easy-to-remember text label (example: “Forward Bilge Pump”) to make it easy for you to identify the device being monitored.

2.5.4 Advanced Configuration...

Certain parameters do not normally need to be set in order for normal operation, but are included in an advanced configuration section for use in special situations.

2.5.5 NMEA 2000® PGN Enable/Disable

The RIM100 is capable of transmitting NMEA 2000® messages (or PGNs) associated with monitored load circuits. You may individually enable or disable each of these messages. You may also change the rate of transmission of each of these messages if desired.

2.5.6 Restore Factory Defaults

Selecting this configuration option causes all stored parameters in the RIM100 to be reset to the values they contained when the unit was manufactured.

2.5.7 Installation Description...

The RIM100, along with all other Level A certified NMEA devices, has two user-programmable installation description fields. You may program these fields with information specific to the device, such as date installed, the initials/name of the installer, the physical location of the device, etc. This configuration option will allow you to program the values of these fields.

3 Maintenance

Regular maintenance is important to ensure continued proper operation of the Maretron RIM100. Perform the following tasks periodically:

- Clean the unit with a soft cloth. Do not use chemical cleaners as they may remove paint or markings or may corrode the RIM100 enclosure or seals.
- Ensure that the unit is mounted securely and cannot be moved relative to the mounting surface. If the unit is loose, tighten the mounting screws.

- Check the security of the cable connected to the NMEA 2000[®] connector, and tighten if necessary.
- Check the security of all of the load connections on the top of the unit and tighten if necessary.

4 Troubleshooting

If you notice unexpected operation of the Maretron RIM100, follow the troubleshooting procedures in this section to remedy simple problems. If these steps do not solve your problem, please contact Maretron Technical Support (refer to Section 6 for contact information).

| Symptom | Troubleshooting Procedure |
|--|---|
| No Run Indicator data visible on NMEA 2000 [®] network. | Ensure that the RIM100 is properly connected to the NMEA 2000 [®] network. Ensure that the monitored loads are properly connected to the RIM100. Ensure that each indicator that you wish to monitor is not configured as "Disabled". Ensure that the RIM100 has the appropriate NMEA 2000 [®] PGNs enabled as described in Section 2.5.5. |
| A Run Indicator always reads "Off" | Ensure that there is not an open circuit in the wiring for the load. With the load running, measure the voltage between the "+" and "-" terminals on the RIM100 to which the load is connected. You should measure an appropriate AC or DC voltage, depending upon the type of load. |

5 Technical Specifications

As Maretron is constantly improving its products, all specifications are subject to change without notice. Maretron products are designed to be accurate and reliable; however, they should be used only as aids to navigation and not as a replacement for traditional navigation aids and techniques.

Specifications

| Parameter | Value | Comment |
|-------------------------|----------------|---------|
| "ON" Voltage Range (DC) | 9VDC to 240VDC | |
| "ON" Voltage Range (AC) | 9VAC to 240VAC | RMS |

Certifications

| Parameter | Comment |
|--|-------------------------------|
| NMEA 2000 [®] Standard | Level A |
| Maritime Navigation and Radiocommunication Equipment & Systems | IEC 61162-3 |
| Maritime Navigation and Radiocommunication Equipment & Systems | IEC 60945 |
| FCC and CE Mark | Electromagnetic Compatibility |

NMEA 2000[®] Parameter Group Numbers (PGNs)

| Description | PGN # | PGN Name | Default Rate |
|----------------------------|--------|----------------------------------|--|
| Periodic Data PGNs | 127501 | Binary Switch Bank Status | 1 time/15 seconds and on switch change |
| Response to Requested PGNs | 126464 | PGN List (Transmit and Receive) | N/A |
| | 126996 | Product Information | N/A |
| | 126998 | Configuration Information | N/A |
| Protocol PGNs | 059392 | ISO Acknowledge | N/A |
| | 059904 | ISO Request | N/A |
| | 060928 | ISO Address Claim | N/A |
| | 065240 | ISO Address Command | N/A |
| | 126208 | NMEA Request/Command/Acknowledge | N/A |
| Maretron Proprietary PGNs | 126720 | Configuration | N/A |

Electrical

| Parameter | Value | Comment |
|-------------------------------|---------------|---|
| Operating Voltage | 9 to 32 Volts | DC Voltage |
| Power Consumption | 50 mA | NMEA 2000 [®] Interface |
| Load Equivalence Number (LEN) | 1 | NMEA 2000 [®] Spec. (1LEN = 50 mA) |
| Reverse Battery Protection | Yes | Indefinitely |
| Load Dump Protection | Yes | Energy Rated per SAE J1113 |

Mechanical

| Parameter | Value | Comment |
|-----------|--|--------------------------------|
| Size | 3.50" x 4.20" x 2.03" (88.9mm x 106.7mm x 51.6mm) | Including Flanges for Mounting |
| Weight | 13 oz. (368.5 g) | |

Environmental

| Parameter | Value |
|--------------------------|--|
| IEC 60945 Classification | Exposed |
| Degree of Protection | IP64 |
| Operating Temperature | -25°C to 55°C |
| Storage Temperature | -40°C to 70°C |
| Relative Humidity | 93%RH @40° per IEC60945-8.2 |
| Vibration | 2-13.2Hz @ ±1mm, 13.2-100Hz @ 7m/s ² per IEC 60945-8.7 |
| Solar Radiation | Ultraviolet B, A, Visible, and Infrared per IEC 60945-8.10 |
| Corrosion (Salt Mist) | 4 times 7days @ 40°C, 95%RH after 2 hour Salt Spray Per IEC 60945-8.12 |
| Electromagnetic Emission | Conducted and Radiated Emission per IEC 60945-9 |
| Electromagnetic Immunity | Conducted, Radiated, Supply, and ESD per IEC 60945-10 |
| Safety Precautions | Dangerous Voltage, Electromagnetic Radio Frequency per IEC 60945-12 |

6 Technical Support

If you require technical support for Maretron products, you can reach us in any of the following ways:

Telephone: 1-866-550-9100
Fax: 1-602-861-1777
E-mail: support@maretron.com
World Wide Web: <http://www.maretron.com>
Mail: Maretron, LLC
Attn: Technical Support
9014 N. 23rd Ave Suite 10
Phoenix, AZ 85021 USA

7 Installation Template

Please check the dimensions before using the following diagram as a template for drilling the mounting holes because the printing process may have distorted the dimensions.

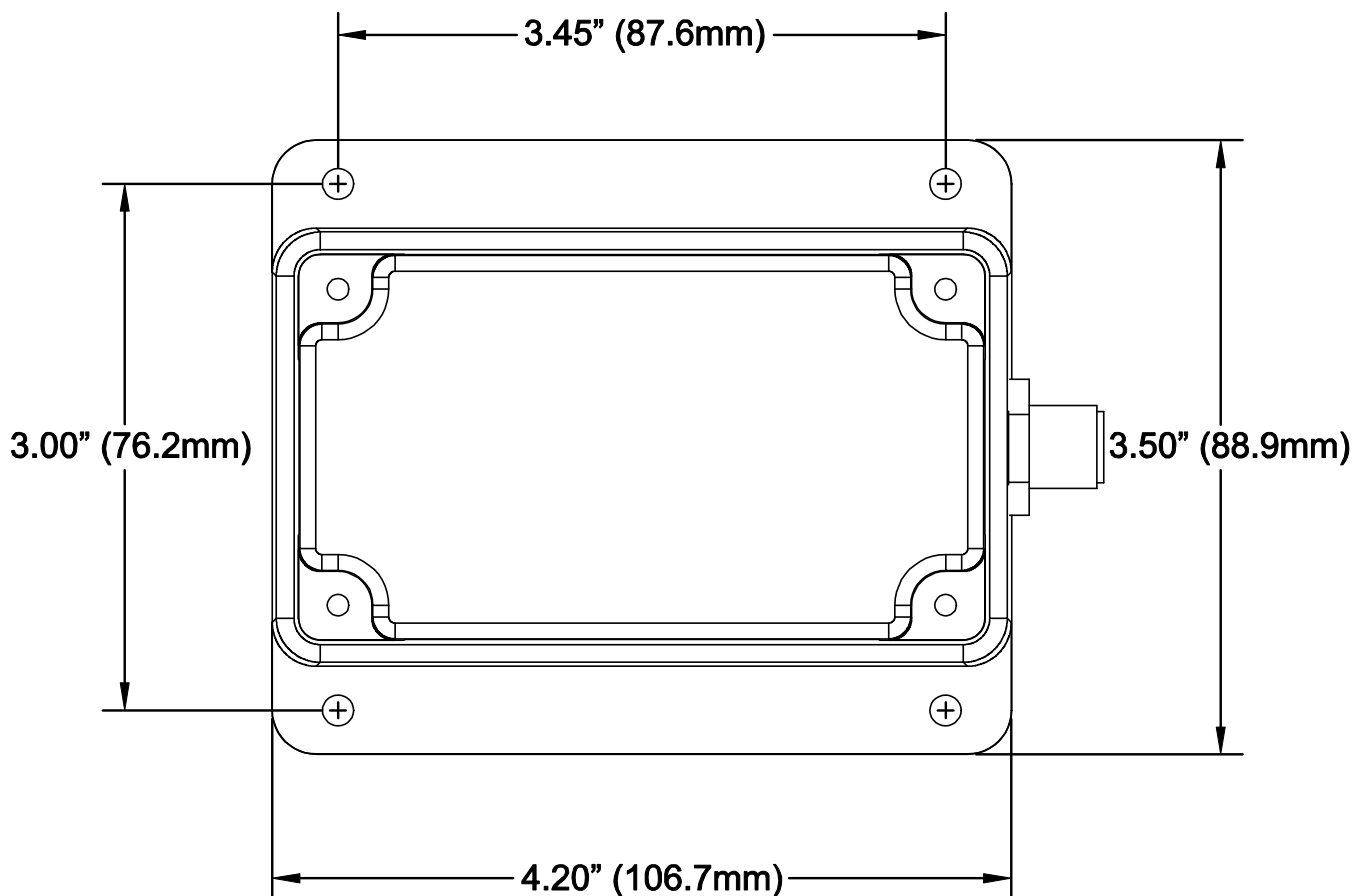

Figure 5 – Mounting Surface Template

8 Maretron (2 Year) Limited Warranty

Maretron warrants the RIM100 to be free from defects in materials and workmanship for **two (2) years** from the date of original purchase. If within the applicable period any such products shall be proved to Maretron's satisfaction to fail to meet the above limited warranty, such products shall be repaired or replaced at Maretron's option. Purchaser's exclusive remedy and Maretron's sole obligation hereunder, provided product is returned pursuant to the return requirements below, shall be limited to the repair or replacement, at Maretron's option, of any product not meeting the above limited warranty and which is returned to Maretron; or if Maretron is unable to deliver a replacement that is free from defects in materials or workmanship, Purchaser's payment for such product will be refunded. Maretron assumes no liability whatsoever for expenses of removing any defective product or part or for installing the repaired product or part or a replacement therefore or for any loss or damage to equipment in connection with which Maretron's products or parts shall be used. With respect to products not manufactured by Maretron, Maretron's warranty obligation shall in all respects conform to and be limited to the warranty actually extended to Maretron by its supplier. The foregoing warranties shall not apply with respect to products subjected to negligence, misuse, misapplication, accident, damages by circumstances beyond Maretron's control, to improper installation, operation, maintenance, or storage, or to other than normal use or service.

THE FOREGOING WARRANTIES ARE EXPRESSLY IN LIEU OF AND EXCLUDES ALL OTHER EXPRESS OR IMPLIED WARRANTIES, INCLUDING BUT NOT LIMITED TO THE IMPLIED WARRANTIES OF MERCHANTABILITY AND OF FITNESS FOR A PARTICULAR PURPOSE.

Statements made by any person, including representatives of Maretron, which are inconsistent or in conflict with the terms of this Limited Warranty, shall not be binding upon Maretron unless reduced to writing and approved by an officer of Maretron.

IN NO CASE WILL MARETRON BE LIABLE FOR INCIDENTAL OR CONSEQUENTIAL DAMAGES, DAMAGES FOR LOSS OF USE, LOSS OF ANTICIPATED PROFITS OR SAVINGS, OR ANY OTHER LOSS INCURRED BECAUSE OF INTERRUPTION OF SERVICE. IN NO EVENT SHALL MARETRON'S AGGREGATE LIABILITY EXCEED THE PURCHASE PRICE OF THE PRODUCT(S) INVOLVED. MARETRON SHALL NOT BE SUBJECT TO ANY OTHER OBLIGATIONS OR LIABILITIES, WHETHER ARISING OUT OF BREACH OF CONTRACT OR WARRANTY, TORT (INCLUDING NEGLIGENCE), OR OTHER THEORIES OF LAW WITH RESPECT TO PRODUCTS SOLD OR SERVICES RENDERED BY MARETRON, OR ANY UNDERTAKINGS, ACTS OR OMISSIONS RELATING THERETO.

Maretron does not warrant that the functions contained in any software programs or products will meet purchaser's requirements or that the operation of the software programs or products will be uninterrupted or error free. Purchaser assumes responsibility for the selection of the software programs or products to achieve the intended results, and for the installation, use and results obtained from said programs or products. No specifications, samples, descriptions, or illustrations provided Maretron to Purchaser, whether directly, in trade literature, brochures or other documentation shall be construed as warranties of any kind, and any failure to conform with such specifications, samples, descriptions, or illustrations shall not constitute any breach of Maretron's limited warranty.

Warranty Return Procedure:

To apply for warranty claims, contact Maretron or one of its dealers to describe the problem and determine the appropriate course of action. If a return is necessary, place the product in its original packaging together with proof of purchase and send to an Authorized Maretron Service Location. You are responsible for all shipping and insurance charges. Maretron will return the replaced or repaired product with all shipping and handling prepaid except for requests requiring expedited shipping (i.e. overnight shipments). Failure to follow this warranty return procedure could result in the product's warranty becoming null and void.

Maretron reserves the right to modify or replace, at its sole discretion, without prior notification, the warranty listed above. To obtain a copy of the then current warranty policy, please go to the following web page:

<http://www.maretron.com/company/warranty.php>

Appendix A – NMEA 2000® Interfacing

RIM100 NMEA 2000® Periodic Data Transmitted PGNs

PGN 127501 – Binary Switch Bank Status

The RIM100 uses this PGN to transmit the state of each of the connected switch inputs

- Field 1: Indicator Bank Instance – This field identifies the particular switch bank to which this PGN applies. Please refer to Section 2.5.1 for instructions on how to program the value of this field.
- 2: Indicator #1 – This field indicates the state of the switch connected to the V1+ and V1- inputs of the RIM100. The state will be one of the following values:
- “Off” – No voltage is detected on the monitored load (the load is not running).
 - “On” – A voltage is detected on the monitored load (the load is running).
 - “Data Not Available” – The indicator is configured as “Disabled”
- 3: Indicator #2 – This field indicates the state of the switch connected to the V2+ and V2- inputs of the RIM100.
- 4: Indicator #3 – This field indicates the state of the switch connected to the V3+ and V3- inputs of the RIM100.
- 5: Indicator #4 – This field indicates the state of the switch connected to the V4+ and V4- inputs of the RIM100.
- 6: Indicator #5 – This field indicates the state of the switch connected to the V5+ and V5- inputs of the RIM100.
- 7: Indicator #6 – This field indicates the state of the switch connected to the V6+ and V6- inputs of the RIM100.