

TLM150 Gasoline Tank Level Monitor

User's Manual

Revision 1.1

Copyright © 2009 Maretron, LLP All Rights Reserved

**Maretron, LLP
9014 N. 23rd Ave #10
Phoenix, AZ 85021
<http://www.maretron.com>**

Maretron Manual Part #: M002301

Revision History

Revision	Description
1.0	Original document
1.1	Corrected typo in NMEA 2000 protocol PGN list Corrected maximum depth in specification table

Table of Contents

1	General	1
1.1	Introduction	1
1.2	Gasoline Tanks	1
1.3	Firmware Revision	1
1.4	Features	1
1.5	TLM150 Accessories	2
1.6	Quick Install	2
2	Installation	2
2.1	Unpacking the Box.....	2
2.2	Choosing a Mounting Location	2
2.2.1	Effect of Pitch and Roll on the TLM150.....	3
2.3	Mounting the TLM150.....	3
2.3.1	Mounting the TLM150 Sensor Component	3
2.3.2	Mounting the TLM150 Interface Component.....	8
2.4	Connecting the TLM150	8
2.4.1	Connecting to NMEA 2000® Interface	8
3	Configuring the TLM150.....	9
3.1	Configuring Tank Number.....	9
3.2	Configuring Tank Capacity	9
3.3	Tank Depth or Custom Calibration.....	10
3.3.1	Tank Depth Programming	10
3.3.2	Custom Calibration.....	10
4	Maintenance.....	10
5	Troubleshooting	10
6	Technical Specifications.....	11
7	Technical Support	13
8	Maretron (2 Year) Limited Warranty	14

Table of Figures

Figure 1 – TLM150 Mounting – SAE 5-Hole Bolt Pattern	4
Figure 2 – Mounting TLM150 to SAE 5-Hole Tank with Focus Tube	5
Figure 3 – TLM150 Mounting With Threaded Adapter.....	6
Figure 4 – Mounting TLM150 with Focus Tube on Threaded Tank Fitting.....	7
Figure 5 – TLM150 Connections	8
Figure 6 – NMEA 2000® Connector Face Views	9
Figure 7 – Troubleshooting Guide	11

Table of Appendices

Appendix A – NMEA 2000® Interfacing.....	A1
--	----

1 General

1.1 Introduction

Congratulations on your purchase of the Maretron Tank Level Monitor (TLM150). Maretron has designed and built your monitor to the highest standards for years of reliable, dependable, and accurate service.

The TLM150 is used to sense levels of gasoline tanks using ultrasonic technology and transmit the gasoline levels over the NMEA 2000® network. This allows you to observe gasoline tank levels anywhere on the vessel where there is an NMEA 2000® compatible display such as the Maretron DSM250. The TLM150 is capable of sensing gasoline tanks up to 24" (0.61m) in depth. It must be used only for tanks containing gasoline.. Unlike most tank senders that only work with rectangular tanks, the TLM150 can be calibrated for irregular tank shapes so you know the true level of your tanks. The TLM150 can be mounted on tanks with a SAE J1810 5-hole mounting pattern, or to tanks using 1.5" NPT or 1.25" BSP threaded openings via available adapters. The TLM150 has an optional focus tube to allow use on boats with planing hulls when the vessel spends a significant amount of time with the bow pitched up.

The Maretron TLM150 is designed to operate within the harsh demands of the marine environment. However, no piece of marine electronic equipment can function properly unless installed, calibrated, and maintained in the correct manner. Please read carefully and follow these instructions for installation, calibration, and usage of the Maretron TLM150 in order to ensure optimal performance.

1.2 Gasoline Tanks

The TLM150 is **ONLY** intended for use in tanks containing gasoline. Do not use the TLM150 in tanks containing diesel fuel, water, oil, or other liquids. Use in tanks containing other liquids will result in inaccurate readings.

1.3 Firmware Revision

This manual corresponds to TLM150 firmware revision 1.1.4.

1.4 Features

The Maretron TLM150 has the following features.

- NMEA 2000® Interface
- Integrated ultrasonic level sensor
- Can be used in tanks up to 24" deep
- SAE J1810 5-hole, 1.5" NPT, or 1.25" BSP Mounting
- Accommodates Irregularly Shaped Tanks with 16 Point Calibration
- Tank Type: Fuel (Gasoline only)
- Programmable Tank Number(s) Up to 16 per Tank Type
- Programmable Tank Capacity

1.5 TLM150 Accessories

Maretron offers the following accessories for the TLM150:

- TA-5H-1.5NPT 1.5" NPT Displacement Hull Tank Adapter
- TA-5H-1.25BSP 1.25" BSP Displacement Hull Tank Adapter
- TFT-5H SAE 5-Bolt Pattern Non-Displacement Hull Focus Tube
- TFT-1.5NPT 1.5" NPT Non-Displacement Hull Focus Tube
- TFT-1.25BSP 1.25" BSP Non-Displacement Hull Focus Tube

1.6 Quick Install

Installing the Maretron TLM150 involves the following steps. Please refer to the individual sections for additional details.

1. Unpack the Box (Section 2.1)
2. Choose a Mounting Location (Section 2.2)
3. Connect the TLM150 (Section 2.3)
4. Configure or Program the Tank Number (Section 3.1)
5. Configure or Program Tank Capacity (Section 3.2)
6. Configure for Tank Depth and Shape
 - Configure or Program the Tank Depth (Section 3.3.1)
 - Custom Calibration (Section 3.3.2)

2 Installation

2.1 Unpacking the Box

When unpacking the box containing the Maretron TLM150, you should find the following items.

- 1 – TLM150 Tank Level Monitor
- 1 – TLM150 Gasket
- 1 – TLM150 User's Manual
- 1 – Warranty Registration Card

If any of these items are missing or damaged, please contact Maretron.

2.2 Choosing a Mounting Location

The primary function of the TLM150 is to sense levels of gasoline in tanks using ultrasonic technology and transmit this information over NMEA 2000[®] network so that gasoline fuel tank level information can be viewed anywhere on the vessel where there is an NMEA 2000[®] compatible display.

The TLM150 tank level monitor consists of two parts: 1) the sensor, which mounts onto the top of the tank and contains the ultrasonic gasoline measurement components, and 2) the interface, which converts the measured data into NMEA 2000[®] format and transmits the data over the NMEA 2000[®] network.

2.2.1 Effect of Pitch and Roll on the TLM150

Assuming that the TLM150 sensor component is mounted on a flat tank top, the TLM150 will operate correctly as long as the vessel does not experience pitch and/or roll in excess of 6° for an extended period of time. This can occur on a sailboat when the boat is heeled over, or on a powerboat with a non-displacement (planing) hull. Temporary pitch and roll due to wave motion and will not adversely affect tank level readings.

If you are in a sailing vessel or a powerboat with a non-displacement hull and will experience pitch and/or roll in excess of 6° for an extended period of time, you can install a Non-Displacement Hull Focus Tube below the sensor (please refer to Section 1.5 on page 2 for ordering information). This is a tube which mounts into the tank before the sensor and directs the ultrasonic waves down to the surface of the liquid and back. With a focus tube, the TLM150 will operate correctly as long as the vessel does not exceed 15° of pitch and/or roll for extended periods of time.

2.3 Mounting the TLM150

2.3.1 Mounting the TLM150 Sensor Component

The TLM150 comes from the factory ready to mount on a tank with the standard SAE J1810 5-Hole mounting pattern. Maretron offers adapters to allow mounting the TLM150 on a tank with a 1.5" NPT connection or a 1.25" BSP connection.

The mounting hole through which the TLM150 measures gasoline level should be located as close to the center of the tank, both front-to-back and side-to-side, as possible. This will ensure maximum accuracy of reading in the event that the vessel experiences pitch and roll.

2.3.1.1 Installation on a Tank with a SAE J1810 5-Bolt Fitting

To install the TLM150 on a tank with a SAE J1850 5-bolt fitting, place the gasket over the tank fitting so that the bolt holes line up. Place the TLM150 sensor component over the gasket so that the bolt holes line up. Insert the mounting bolts through the TLM150 sensor component and gasket into the tank fitting (the tank fitting may instead have studs installed, so in this case, install the nuts over the studs), and tighten them to a torque of 10-15 ft-lbs (13.6-20.3 N·m).

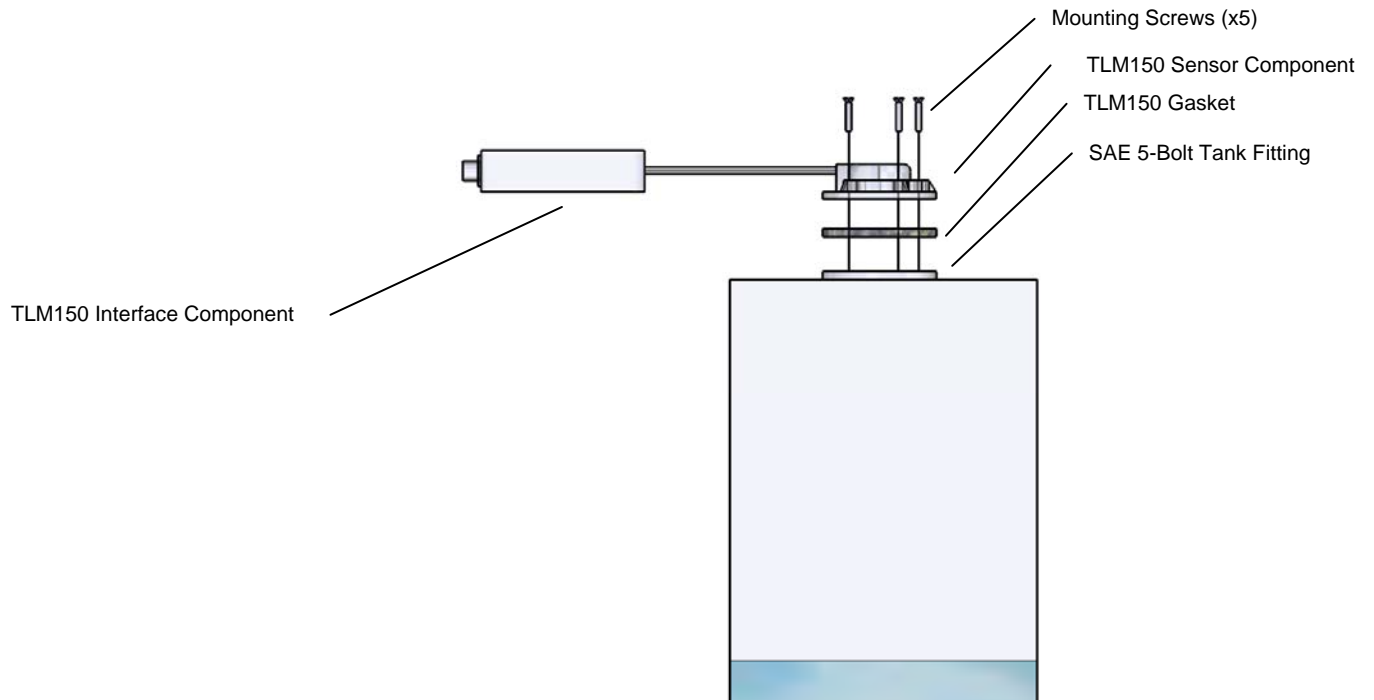

Figure 1 – TLM150 Mounting – SAE 5-Hole Bolt Pattern

2.3.1.2 Installation on a Tank with a SAE J1810 5-Bolt Fitting and Focus Tube

If a focus tube is used for a tank with a SAE J1810 5-bolt fitting, determine the depth of the tank at the location of the tank sensor mounting hole and use a saw with a metal-cutting blade to trim the focus tube so that it reaches 1" above the tank bottom when mounted. Remove any burrs from the end of the focus tube after trimming.

Next, place the gasket included with the focus tube over the focus tube (between the focus tube flange and the tank mounting flange), and then drop the focus tube into the hole so that the bolt holes on the focus tube, focus tube gasket, and tank fitting all line up.

Place the gasket included with the TLM150 over the focus tube so that the bolt holes line up, then place the TLM150 sensor component on top of the TLM150 gasket so that the bolt holes line up.

Insert mounting screws into the bolt holes on the TLM150 sensor component, and thread them into the tank fitting (the tank fitting may instead have studs installed, so in this case, install the nuts over the studs), tightening them to a torque of 10-15 ft-lbs (13.6-20.3 N·m).

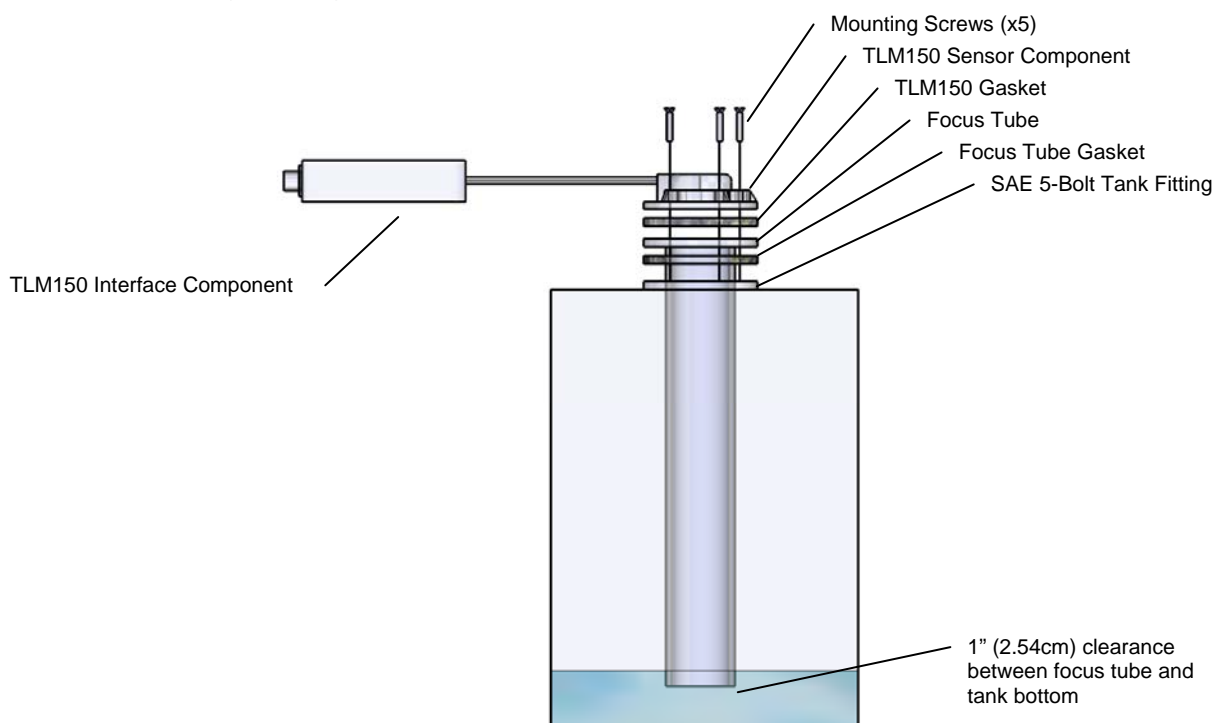

Figure 2 – Mounting TLM150 to SAE 5-Hole Tank with Focus Tube

2.3.1.3 Installation on a Tank with a 1.25" BSP or 1.5" NPT Threaded Tank Fitting

For a threaded tank sender mounting hole, first thread the adapter into the tank opening and tighten to a torque of 3-5 ft-lbs (4.1-6.8 N·m).

Next, place the TLM150 gasket over the adapter so that the bolt holes on the gasket line up with the bolt holes on the adapter. Place the TLM150 sensor component on top of the adapter so that the bolt holes on the TLM150 sensor component line up with the bolt holes on the adapter.

Place the included mounting screws through the bolt holes on the TLM150 sensor component, and thread them into the adapter, tightening them to a torque of 10-15 ft-lbs (13.6-20.3 N·m).

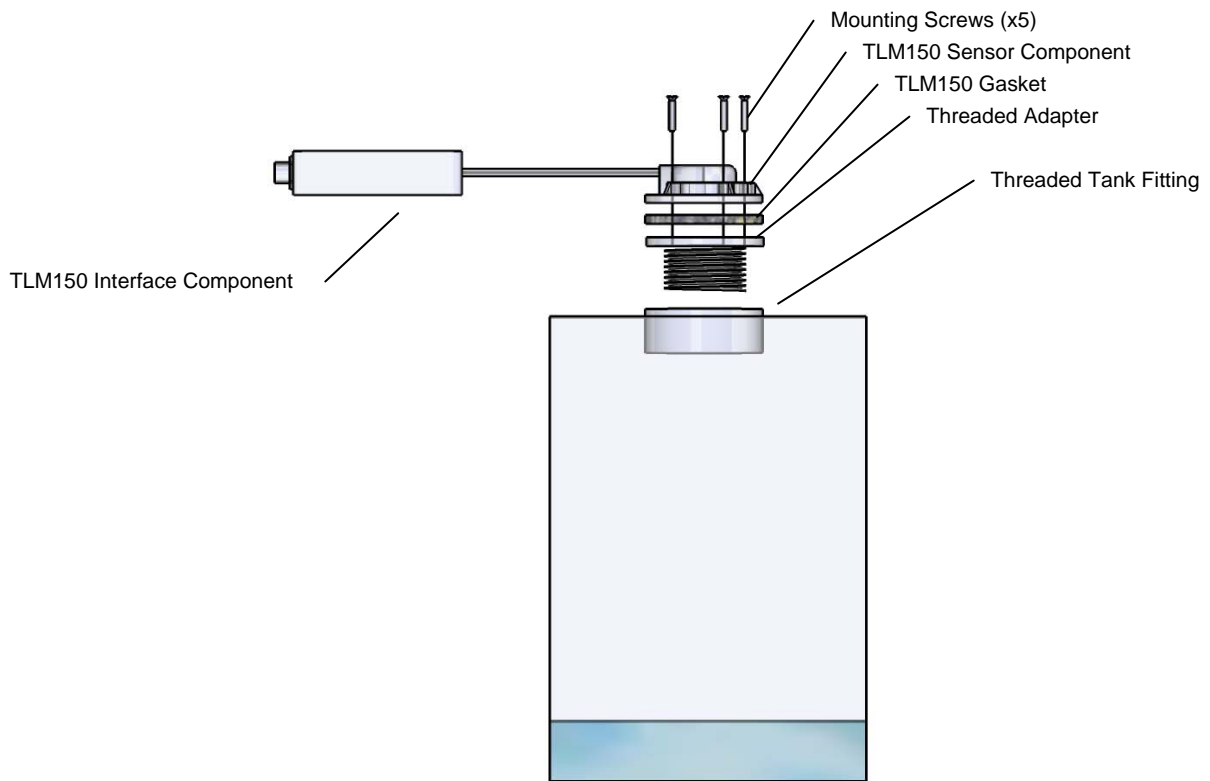

Figure 3 – TLM150 Mounting With Threaded Adapter

2.3.1.4 Installation on a Tank with a 1.25" BSP or 1.5" NPT Threaded Tank Fitting and Focus Tube

If a focus tube is used for a tank with a SAE J1810 5-bolt fitting, determine the depth of the tank at the location of the tank sensor mounting hole and use a saw with a metal-cutting blade to trim the focus tube so that it reaches 1" above the tank bottom when mounted. Remove any burrs from the end of the focus tube after trimming.

For a threaded tank sender mounting hole, first thread the adapter into the tank opening and tighten to a torque of 3-5 ft-lbs (4.1-6.8 N·m).

Next, place the TLM150 gasket over the adapter so that the bolt holes on the gasket line up with the bolt holes on the adapter. Place the TLM150 sensor component on top of the adapter so that the bolt holes on the TLM150 sensor component line up with the bolt holes on the adapter.

Place the included mounting screws through the bolt holes on the TLM150 sensor component, and thread them into the adapter, tightening them to a torque of 10-15 ft-lbs (13.6-20.3 N·m).

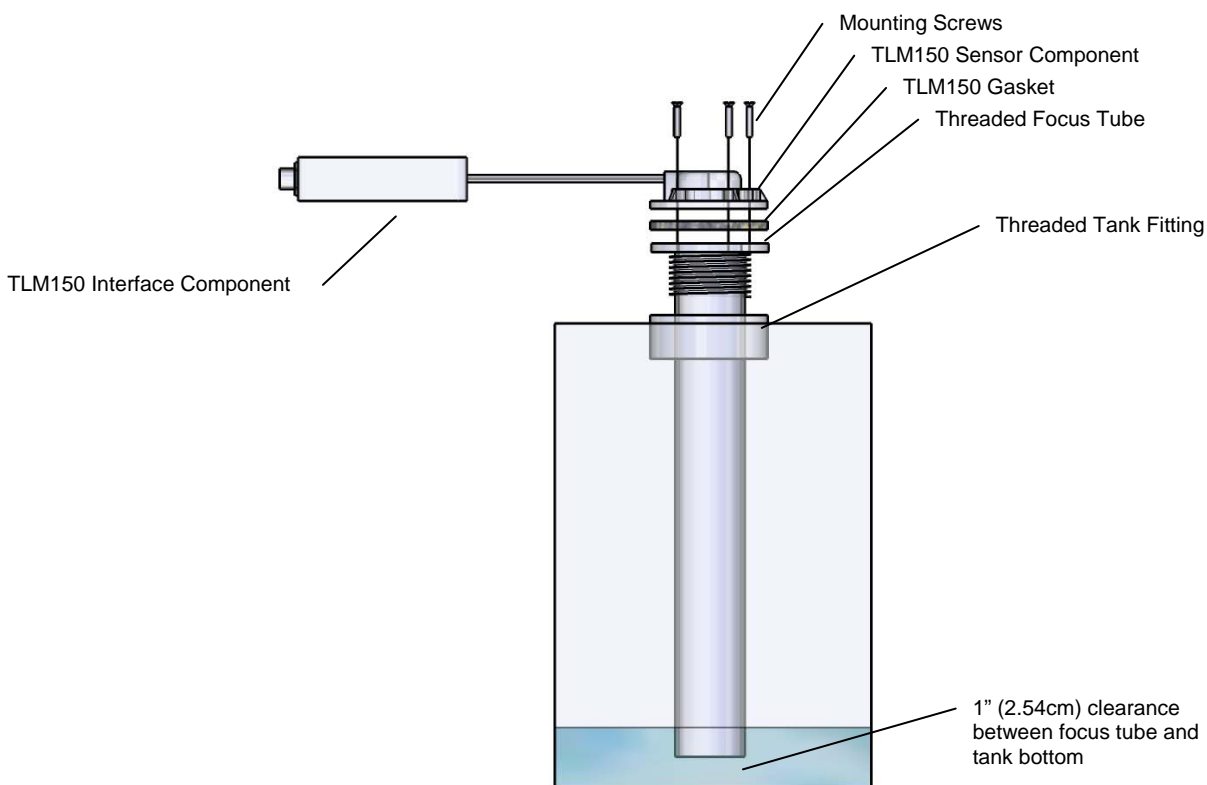

Figure 4 – Mounting TLM150 with Focus Tube on Threaded Tank Fitting

2.3.2 Mounting the TLM150 Interface Component

The actual mounting of the TLM150 interface component is not critical and the unit can be mounted in any orientation. The TLM150, NMEA 2000[®] connector, and cable are all waterproof (rated IP67 – protected against temporary immersion in water) so you can mount the unit virtually anywhere. Once you have located a suitable mounting location, you can secure the TLM150 interface component by placing wire ties with screw eyes on the attached cables next to the TLM150 interface component.

2.4 Connecting the TLM150

There is one connection point (see Figure 5) for the TLM150: the NMEA 2000[®] connection. Please refer to Section 2.4.1 for making NMEA 2000[®] connection.



Figure 5 – TLM150 Connections

2.4.1 Connecting to NMEA 2000[®] Interface

The Maretron TLM150 provides a connection to an NMEA 2000[®] interface through a five pin male connector (see Figure 6). You connect the TLM150 to an NMEA 2000[®] network using a Maretron NMEA 2000[®] cable (or an NMEA 2000[®] compatible cable) by connecting the female end of the cable to the TLM150 (note the key on the male connector and keyway on the female connector). Be sure the cable is connected securely and that the collar on the cable connector is tightened firmly. Connect the other end of the cable (male) to the NMEA 2000[®] network in the same manner. The TLM150 is designed such that you can plug or unplug it from an NMEA 2000[®] network while the power to the network is connected or disconnected. Please follow recommended practices for installing NMEA 2000[®] network products.

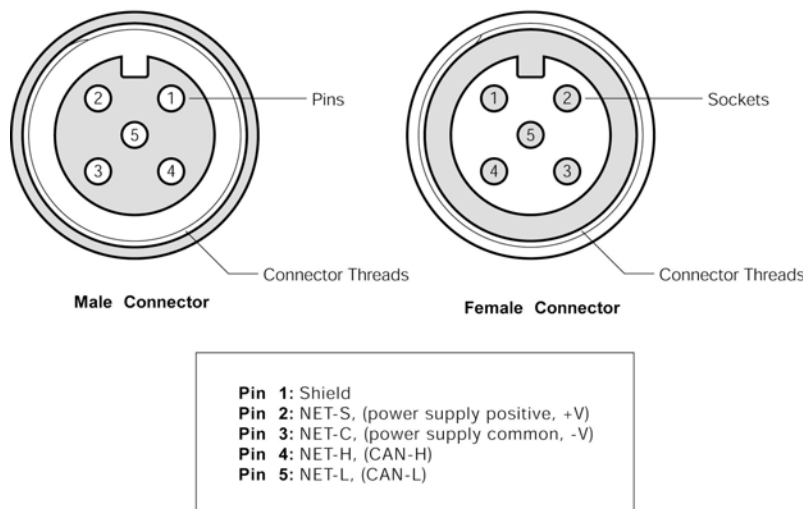

Figure 6 – NMEA 2000® Connector Face Views

3 Configuring the TLM150

The TLM150 has several configurable parameters, which are shown below including the default values. If you are not using the default values, then you will need to refer to the corresponding section for configuring the TLM150 appropriately.

1. Tank Number – Default is Tank 0 (Section 3.1)
2. Tank Capacity – Default is No Tank Capacity Transmitted (Section 3.2)
3. Tank Depth or Custom Calibration – Default is a 40" (1.02m) deep tank with rectangular cross-section (Section 3.3.1)

Note on Tank Type:

As shipped from the factory, the TLM150 transmits the tank type as “Fuel”. Since the TLM150 is designed only for tanks containing gasoline, the tank type is not changeable by the user.

3.1 Configuring Tank Number

As shipped from the factory, the TLM150 transmits the Tank Number as “0”. The TLM150 supports up to sixteen tanks (0 through 15) for a given type of tank, which means you can monitor up to 16 separate fuel tanks. The TLM150 is configured or programmed by choosing a TLM150 tank number using a display product such as the Maretron DSM250. Refer to the *DSM250 User's Manual* for configuring the TLM150 as the manual provides detailed instruction on configuration procedures.

3.2 Configuring Tank Capacity

In addition to indicating the gasoline level within a tank, the TLM150 also has the ability to be configured or programmed with the attached tank's capacity. This way, you will be able to view the tank's capacity as well as the amount of gasoline remaining anywhere on the vessel where

there is an NMEA 2000[®] compatible display. It is not required, but you can enter the TLM150 tank capacity using a display product such as the Maretron DSM250. Refer to the *DSM250 User's Manual* for configuring the TLM150 as the manual provides detailed instruction on configuration procedures.

3.3 Tank Depth or Custom Calibration

The TLM150 can be easily programmed for use with tanks of rectangular cross-section (see Section 3.3.1). For non-rectangular tank shapes, you can perform custom calibration so that the TLM150 accurately reflects gasoline levels (see Section 3.3.2).

3.3.1 Tank Depth Programming

The TLM150 can be used with tanks that have rectangular cross sections. The TLM150 comes from the factory programmed for a 24" (0.16m) deep tank. In order to obtain correct level readings on a tank having a rectangular cross section but shallower than 24", you must program the TLM150 with the actual depth of the tank using a display product such as the Maretron DSM250. Refer to the *DSM250 User's Manual* for configuring the TLM150 as the manual provides detailed instruction on configuration procedures.

3.3.2 Custom Calibration

For accurate tank level readings, the TLM150 must be custom calibrated if the tank shape is irregular or non-rectangular.

You can calibrate the TLM150 using a display product such as the Maretron DSM250. Refer to the user's manual of the particular product that will be used for configuring the TLM150 as these manuals provide detailed instruction on configuration procedures.

4 Maintenance

Regular maintenance is not required; however, an occasional inspection will ensure continued proper operation of the Maretron TLM150. Perform the following tasks periodically:

- Ensure that the unit is mounted securely and cannot be moved relative to the mounting surface. If the unit is loose, tighten the screws holding the cable ties.
- Check the security of the cable connected to the NMEA 2000[®] interface and tighten if necessary.

5 Troubleshooting

If you notice unexpected operation of the Maretron TLM150, follow the troubleshooting procedures in this section to remedy simple problems.

Symptom	Troubleshooting Procedure
No tank level output	<ol style="list-style-type: none">1. If operating in the <i>NMEA 2000[®] Mode</i>, check the connection to the NMEA 2000[®] interface (see Section 2.4.1) and tighten if necessary.2. Ensure that power is supplied to the NMEA 2000[®] network. Proper network power can be checked by measuring the voltage at an open

Symptom	Troubleshooting Procedure
	<p>tee between NET-S and NET-C. The voltage should be between 9 and 16 volts.</p> <ol style="list-style-type: none"> Ensure that both trunk line terminators are in place. Proper network termination can be checked by removing network power and measuring the resistance at an open tee between NET-L and NET-H signals. The resistance should read approximately 60 ohms (two 120 ohm terminators in parallel equals 60 ohms). Removed the TLM150 sensor component from the tank opening and ensure that the surface of the ultrasonic sensor is not fouled.
Inaccurate tank level output	<ol style="list-style-type: none"> If operating with a rectangular tank, ensure that the tank depth is programmed properly (see Section 3.3.1). If using custom calibration, re-calibrate the TLM150 (see Section 3.3.2). Ensure that the tank contains gasoline. Gasoline vapors must be present in the tank in order for depth readings to be accurate. If you have another fluid type, please use the Maretron TLM100 or TLM200 tank level monitors.

Figure 7 – Troubleshooting Guide

If these steps do not solve your problem, please contact Maretron Technical Support (refer to Section 7 for contact information).

6 Technical Specifications

Specifications

Parameter	Value	Comment
Accuracy	+/-2%	
Resolution	+/-1%	
Number of Tank Types	1	Fuel (Gasoline only)
Number of Tanks per Tank Type	16	16 Tanks per Tank Type Numbered 0-15
Maximum Tank Depth	24" (0.61m)	
Minimum Depth Reading	2" (5.08cm)	Sensor Deadband
Support for Irregularly Shaped Tanks	Yes	Can be Calibrated for any Shape Tank
Programmable Tank Capacity	Yes	Allows Displays to Calculate Amount Remaining
Maximum Tank Angle	6°	Without focus tube
	15°	With focus tube

Certifications

Parameter	Comment
NMEA 2000	Level B+
Maritime Navigation and Radiocommunication Equipment & Systems	Tested to IEC 60945
FCC and CE Mark	Electromagnetic Compatibility

TLM150 User's Manual

NMEA 2000[®] Parameter Group Numbers (PGNs) - See Appendix A for Details

Description	PGN #	PGN Name	Default Rate
Periodic Data PGNs	127505	Fluid Level	0.4 Times/Second
Response to Requested PGNs	126464	PGN List (Transmit and Receive)	N/A
	126996	Product Information	N/A
	126998	Configuration Information	N/A
Protocol PGNs	059392	ISO Acknowledge	N/A
	059904	ISO Request	N/A
	060928	ISO Address Claim	N/A
	065240	ISO Address Command	N/A
	126208	NMEA	N/A

Electrical

Parameter	Value	Comment
Operating Voltage	9 to 16 Volts	DC Voltage
Power Consumption	<100mA	Average Current Drain
Load Equivalence Number (LEN)	2	NMEA 2000 [®] Spec. (1LEN = 50mA)
Reverse Battery Protection	Yes	Indefinitely
Load Dump Protection	Yes	Energy Rated per SAE J1113

Mechanical

Parameter	Value	Comment
Size	3.9" x 1.2" x 1.0" (99mm x 30.5mm x 25.4mm)	Interface Component
	2.7" dia. X 0.9" (68.6mm dia. x 22.9mm)	Sensor Component
	8.5" (215.9mm)	Interconnecting Cable
Weight	12 oz. (340g)	
Mounting	SAE J1810 5-hole bolt pattern	Can mount to 1.25" BSP or 1.5" NPT using available adapters

Environmental

Parameter	Value
IEC 60945 Classification	Exposed
Degree of Protection	IP67
Operating Temperature	-25°C to 55°C
Storage Temperature	-40°C to 70°C
Relative Humidity	93%RH @40° per IEC60945-8.2
Vibration	2-13.2Hz @ ±1mm, 13.2-100Hz @ 7m/s ² per IEC 60945-8.7
Rain and Spray	12.5mm Nozzle @ 100liters/min from 3m for 30min per IEC 60945-8.8
Solar Radiation	Ultraviolet B, A, Visible, and Infrared per IEC 60945-8.10
Corrosion (Salt Mist)	4 times 7days @ 40°C, 95%RH after 2 hour Salt Spray Per IEC 60945-8.12
Electromagnet Emission	Conducted and Radiated Emission per IEC 60945-9
Electromagnetic Immunity	Conducted, Radiated, Supply, and ESD per IEC 60945-10
Safety Precautions	Dangerous Voltage, Electromagnetic Radio Frequency per IEC 60945-12

7 Technical Support

If you require technical support for Maretron products, you can reach us in one of the following ways:

Telephone: 1-866-550-9100
Fax: 1-602-861-1777
E-mail: support@maretron.com
World Wide Web: <http://www.maretron.com>
Mail: Maretron, LLP
Attn: Technical Support
9014 N. 23rd Ave Suite 10
Phoenix, AZ 85021 USA

8 Maretron (2 Year) Limited Warranty

Maretron warrants the TLM150 to be free from defects in materials and workmanship for **two (2) years** from the date of original purchase. If within the applicable period any such products shall be proved to Maretron's satisfaction to fail to meet the above limited warranty, such products shall be repaired or replaced at Maretron's option. Purchaser's exclusive remedy and Maretron's sole obligation hereunder, provided product is returned pursuant to the return requirements below, shall be limited to the repair or replacement, at Maretron's option, of any product not meeting the above limited warranty and which is returned to Maretron; or if Maretron is unable to deliver a replacement that is free from defects in materials or workmanship, Purchaser's payment for such product will be refunded. Maretron assumes no liability whatsoever for expenses of removing any defective product or part or for installing the repaired product or part or a replacement therefore or for any loss or damage to equipment in connection with which Maretron's products or parts shall be used. With respect to products not manufactured by Maretron, Maretron's warranty obligation shall in all respects conform to and be limited to the warranty actually extended to Maretron by its supplier. The foregoing warranties shall not apply with respect to products subjected to negligence, misuse, misapplication, accident, damages by circumstances beyond Maretron's control, to improper installation, operation, maintenance, or storage, or to other than normal use or service.

THE FOREGOING WARRANTIES ARE EXPRESSLY IN LIEU OF AND EXCLUDES ALL OTHER EXPRESS OR IMPLIED WARRANTIES, INCLUDING BUT NOT LIMITED TO THE IMPLIED WARRANTIES OF MERCHANTABILITY AND OF FITNESS FOR A PARTICULAR PURPOSE.

Statements made by any person, including representatives of Maretron, which are inconsistent or in conflict with the terms of this Limited Warranty, shall not be binding upon Maretron unless reduced to writing and approved by an officer of Maretron.

IN NO CASE WILL MARETRON BE LIABLE FOR INCIDENTAL OR CONSEQUENTIAL DAMAGES, DAMAGES FOR LOSS OF USE, LOSS OF ANTICIPATED PROFITS OR SAVINGS, OR ANY OTHER LOSS INCURRED BECAUSE OF INTERRUPTION OF SERVICE. IN NO EVENT SHALL MARETRON'S AGGREGATE LIABILITY EXCEED THE PURCHASE PRICE OF THE PRODUCT(S) INVOLVED. MARETRON SHALL NOT BE SUBJECT TO ANY OTHER OBLIGATIONS OR LIABILITIES, WHETHER ARISING OUT OF BREACH OF CONTRACT OR WARRANTY, TORT (INCLUDING NEGLIGENCE), OR OTHER THEORIES OF LAW WITH RESPECT TO PRODUCTS SOLD OR SERVICES RENDERED BY MARETRON, OR ANY UNDERTAKINGS, ACTS OR OMISSIONS RELATING THERETO.

Maretron does not warrant that the functions contained in any software programs or products will meet purchaser's requirements or that the operation of the software programs or products will be uninterrupted or error free. Purchaser assumes responsibility for the selection of the software programs or products to achieve the intended results, and for the installation, use and results obtained from said programs or products. No specifications, samples, descriptions, or illustrations provided Maretron to Purchaser, whether directly, in trade literature, brochures or other documentation shall be construed as warranties of any kind, and any failure to conform with such specifications, samples, descriptions, or illustrations shall not constitute any breach of Maretron's limited warranty.

Warranty Return Procedure:

To apply for warranty claims, contact Maretron or one of its dealers to describe the problem and determine the appropriate course of action. If a return is necessary, place the product in its original packaging together with proof of purchase and send to an Authorized Maretron Service Location. You are responsible for all shipping and insurance charges. Maretron will return the replaced or repaired product with all shipping and handling prepaid except for requests requiring expedited shipping (i.e. overnight shipments). Failure to follow this warranty return procedure could result in the product's warranty becoming null and void.

Maretron reserves the right to modify or replace, at its sole discretion, without prior notification, the warranty listed above. To obtain a copy of the then current warranty policy, please go to the following web page:

<http://www.maretron.com/company/warranty.php>

Appendix A – NMEA 2000® Interfacing

TLM150 NMEA 2000® Periodic Data Transmitted PGNs

PGN 127505 – Fluid Level

The TLM150 uses this PGN to indicate the attached tank's fluid instance, fluid type, fluid level, and tank capacity.

- Field 1: Fluid Instance – This field is used to identify the tank number and ranges between 0 and 15. There can be up to 16 tanks of a given type as defined by the Fluid Type field. This field is programmable through the NMEA command PGN. The TLM150 ships from the factory with a default value of zero.
- 2: Fluid Type – This field identifies the type of fluid contained within the tank. Currently the defined fluid types are fuel, fresh water, wastewater, live well, oil, and black water. The TLM150 ships from the factory with a fixed value of 0x0 indicating "Fuel".
- 3: Fluid Level – This field is used to indicate the current fluid level in percentage. The value transmitted in this field depends on the sender resistance value..
- 4: Tank Capacity – This field is used to indicate the tank capacity. The TLM150 ships from the factory with a default value of 0xFFFFFFFF indicating "Data Not Available".
- 5: Reserved – This field is reserved by NMEA; therefore, the TLM150 sets all bits to a logic 1.