

E-Series Networked Display Installation Manual

Document Number: 87043_1
Date: December 2004

Trademarks and registered trademarks

Autohelm, HSB, Raymarine, RayTech, RayTech Navigator, Sail Pilot, SeaTalk and Sportpilot are registered trademarks of Raymarine Limited. Apelco is a registered trademark of Raymarine Holdings Limited (Registered in all major marketing territories).

AST, Autoadapt, Auto GST, Autoseastate, Autotrim, Bidata, Marine Intelligence, Maxiview, On Board, Raychart, Raynav, Raypilot, Raystar, ST40, ST60, Seaclutter, Smart Route, Tridata and Waypoint Navigation are trademarks of Raymarine Limited.

Navionics is a registered trademark of Navionics Company, Italy. All other product names are trademarks or registered trademarks of their respective owners.

Copyright: ©Raymarine 2004

Chapter 1:	Preparation for installation	1
1.1	General information	1
	Intended use	1
	Contents of this pack	2
	Pack details	2
	Dimensions	3
	E80 Display	3
	E120 Display	3
	Accessories and spares	4
	Accessories	4
	Spares	4
1.2	Planning the installation	5
	EMC Installation Guidelines	5
	Suppression Ferrites	6
	Connections to other equipment	6
	Where should the Display unit be located?	6
	EMC Conformance	6
Chapter 2:	System Integration	7
2.1	What is System Integration?	7
	What is SeaTalk?	7
	SeaTalk	7
	SeaTalk2	7
	What is SeaTalk High Speed?	8
	What is NMEA?	8
	NMEA 0183	8
	NMEA 2000	8
2.2	Compatibility	9
	Radar Scanners	9
	Digital Sounder Module	9
	Media storage cards	10
	Navionics Chart cards	10
	CompactFlash cards	10
2.3	Functionality	10
2.4	How is an E-Series integrated?	11
	Single display system	12
	Networking E-Series Displays	13
	A typical two node system incorporating two displays	14
	An example of a three (or more) node system	15

Chapter 3:	Installation	17
3.1	How can the display unit be mounted?	17
	Mounting the Display on the trunnion bracket	17
	Flush mounting the Display	19
	How is the front cover clip-on attached to the display?	20
	How do I remove the front cover clip-on?	21
3.2	Cables	22
	Siting and securing cables	22
	What cables do I need to connect?	22
	How are the cables connected to the display?	23
	How do I use the cable splicers?	24
	Power cable	24
	Extension cable	25
	Fuse ratings	25
	SeaTalk/Alarm out cable	25
	NMEA 0183 cable	26
	SeaTalk High Speed cable	26
	Two node system	26
	3 or more node system	26
	Video In cable	26
	Composite source type	27
	S-Video source type (not supplied)	27
	VGA Out (not supplied)	27
	SeaTalk2 (not supplied)	27
	Radar cable (not supplied)	28
	Connecting to a Radome	28
	Connecting to an open array	28
	...for new installations	28
	... to replace a Raymarine Pathfinder Display	29
Chapter 4:	Commissioning the system	31
4.1	Introduction	31
4.2	What input does my E-Series require?	31
4.3	Pre-start checks	32
	Radar	32
	Fishfinder	32
	GPS	32
4.4	Initial power on procedure	33
4.5	How do I test and align the radar?	33
	Radar transmission check	34

Radar alignment checks	34
Bearing alignment	35
... with your boat moored	35
... with your boat under way	35
How do I adjust the bearing alignment?	35
4.6 How do I check the GPS?	36
4.7 How do I check the heading data?	37
4.8 How do I check the Chart application?	37
4.9 How do I test the Fishfinder application?	38
4.10 How do I test the video?	39
4.11 How do I test the SeaTalkHS Switch connection?	39
4.12 How do I test instrument data?	39
From SeaTalk or SeaTalk2	39
From third party devices on NMEA 0183	39
Chapter 5: Troubleshooting	41
5.1 How can I troubleshoot my Display?	41
5.2 How can I get Technical Support?	42
World wide web	42
Help us to help you	42
How can I contact Raymarine in the US?	43
Who do I contact for accessories and parts?	43
Who do I contact for product repair and service?	43
How can I contact Raymarine in Europe?	44

Table of Contents

Important Information

Safety notices

**WARNING:Navigation aid**

This product is intended to be used as an aid to navigation. Its accuracy can be affected by many factors, including equipment failure or defect, environmental conditions and incorrect handling or use. It is the Users responsibility to exercise common prudence and navigational judgement. This device should not be relied upon as a substitute for such prudence and judgement.

**WARNING:Product installation**

This equipment must be installed in accordance with the instructions in this handbook. Failure to do so could result in poor product performance, personal injury and/or damage to the vessel.

**WARNING:Electrical safety**

Make sure the power supply is switched off before making any electrical connections.

**WARNING:Electromagnetic energy**

The radar scanner transmits electromagnetic energy. Ensure that the scanner has been installed according to the recommendations given in the relevant scanner handbook.

**WARNING:Fishfinder sounder module**

Removing the transducer cable from the fishfinder sounder module whilst it is switched on can cause sparks and may damage the unit. Only remove the transducer cable after power has been switched off. Ensure that the sounder module is mounted where it is well ventilated and in an area free from flammable vapors.

CAUTION: Radar Scanners, Cables & Installation

Information on radar scanners, cables and their installation contained in this handbook supersedes that contained in the Pathfinder Radar Scanner Handbook, Document No. 81154_6, dated 11th March 2002.

CAUTION: Front cover clip-on installation

After installing the front cover clip-on, check that all buttons and soft keys have passed through completely and are free to operate correctly.

CAUTION: Global Positioning System Antenna

Do not connect or disconnect the GPS antenna from the display unit whilst power is switched on. Doing this may result in irreparable damage

CAUTION: Water Ingress

To prevent the ingress of water and damage to the display:

- Ensure that the chart card door is firmly closed. This can be confirmed by an audible click.
- Do not remove the SeaTalk High Speed blanking plug from the rear of the display until such time as you are ready to connect the cable.
- Ensure that the SeaTalk High Speed cable is clicked into place AND then turned to lock it.

CAUTION: Connections into display

Ensure power is switched off prior to connecting or removing any cables into the rear of the display. Failure to do so can cause irreparable damage.

CAUTION: CompactFlash Card Installation

When installing CompactFlash cards ensure that the card is being fitted the correct way round. DO NOT try and force the card into position as this may result in irreparable damage to the card.

CAUTION: CompactFlash Cards

Removing the CompactFlash card whilst information is being written to it may cause damage to the card and loss of all data. A warning on the display indicates when writing is in progress.

CAUTION: Chart and CompactFlash card damage

DO NOT use a metallic instrument such as a screwdriver or pliers to help you remove a card, as doing this can cause irreparable damage to the card and/or display unit.

EMC Conformance

All Raymarine equipment and accessories are designed to the best industry standards for use in the recreational marine environment.

The design and manufacture of Raymarine equipment and accessories conform to the appropriate Electromagnetic Compatibility (EMC) standards, but correct installation is required to ensure that performance is not compromised.

Handbook information

To the best of our knowledge, the information in this handbook was correct when it went to press. However, Raymarine cannot accept liability for inaccuracies or omissions it may contain.

In addition, our policy of continuous product improvement may change specifications without notice. Therefore Raymarine cannot accept liability for any differences between the product and the handbook.

Chapter 1: Preparation for installation

1.1 General information

Intended use

This handbook provides information and instructions to assist in planning and installing your Raymarine E-Series Networked Display, together with information that will be useful when you are connecting the E-Series Display to other equipment.

In order to obtain the best results in operation and performance, please read this handbook thoroughly.

Contents of this pack

The E- Series (E80 or E120) Networked Display pack contains the following items:

Pack details

Part name	Part no.	
	E80	E120
Networked display	E02011	E02013
Front cover clip-on	R58183	R58194
Sun cover	R58184	R58195
Cables (all 1.5m): <ul style="list-style-type: none"> • Power • NMEA • SeaTalk/Alarm out • SeaTalk High Speed Network • Video-in cable 	R89005 E55053 E55054 E55049 E55057	
Cable splice (x3)	07453	
For trunnion mounting the display: <ul style="list-style-type: none"> • Trunnion bracket • Trunnion bracket knobs (x2) • Bolt M6 x 50 (x5) • Washer M6 penny (x5) • Nut M6 Nylok (x5) 	R58204 3034-009 23055 22030	R58205 3034-009 23055 22030
For flush mounting the display: <ul style="list-style-type: none"> • Panel seal • Bolts - M4 x 40 hexhead (x4) • Nuts - M4 (x4) • Washers - M4 (x4) • Spring washers - M4 (x4) 	R58182 15510 22024 23070 23040	R58193 155510 22024 23070 23040
Document wallet containing: <ul style="list-style-type: none"> • Reference Manual • Installation Manual • Operating Guide • Flush mount template 	84176_1	
Cleaning cloth	4472-001-f	

Note: To prevent damage, unpack the display carefully. Save the carton and packing, in case the unit has to be returned for service.

Dimensions

The dimensions for your E-Series display are:

E80 Display

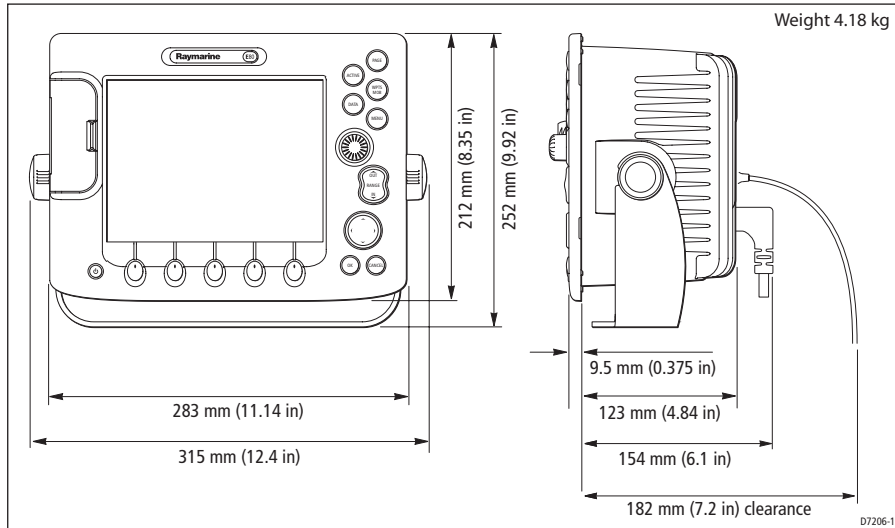

E120 Display

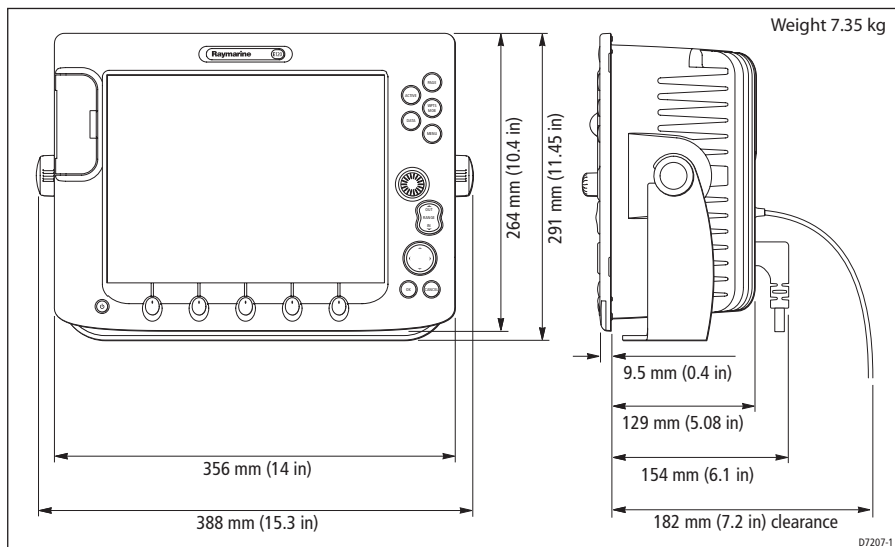

Accessories and spares

Raymarine accessories and parts can be obtained from your authorized Raymarine dealer. However, if you are in need of an item not available from the retailer or you are uncertain what item to choose for your Display, please contact Raymarine direct - See "How can I get Technical Support?" on page 42.

Accessories

The following accessories can be purchased to enhance your E-Series display:

Accessory item	Part no.
Cables:	
• SeaTalk High Speed Network (1.5m)	E55049
• SeaTalk High Speed Network (5m)	E55050
• SeaTalk High Speed Network (10m)	E55051
• SeaTalk High Speed Network (20m)	E55052
• SeaTalk ² /NMEA 2000 (1.5m)	E55053
• SeaTalk/Alarm Out (1.5m)	E55054
• VGA Out (10m)	E55055
• VGA Out (20m)	E55056
• Video In - Composite (1.5m)	E55057
• Video In - S-Video (1.5m)	E55062
SeaTalk High Speed Network Switch	E55058
NMEA 0183 Multiplexer	E55059
SeaTalk High Speed Network Crossover Coupler	E55060
M1500 Monitor	E02009

Spares

You can purchase the following spares:

Spares item	Part no.	
	E80	E120
Flush mount seal	R58182	R58193
Front cover clip-on	R58183	R58194
Sun cover	R58184	R58195

1.2 Planning the installation

This section provides information and advice for planning the installation of your Display.

EMC Installation Guidelines

All Raymarine equipment and accessories are designed to the best industry standards for use in the recreational marine environment.

Their design and manufacture conforms to the appropriate Electromagnetic Compatibility (EMC) standards, but correct installation is required to ensure that performance is not compromised. Although every effort has been taken to ensure that they will perform under all conditions, it is important to understand what factors could affect the operation of the product.

The guidelines given here describe the conditions for optimum EMC performance, but it is recognized that it may not be possible to meet all of these conditions in all situations. To ensure the best possible conditions for EMC performance within the constraints imposed by any location, always ensure the maximum separation possible between different items of electrical equipment.

For **optimum** EMC performance, it is recommended that **wherever possible**:

- Raymarine equipment and cables connected to it are:
 - At least 3 ft. (1 m) from any equipment transmitting or cables carrying radio signals e.g. VHF radios, cables and antennas. In the case of SSB radios, the distance should be increased to 7 ft. (2 m).
 - More than 7 ft. (2 m) from the path of a radar beam. A radar beam can normally be assumed to spread 20 degrees above and below the radiating element.
- The equipment is supplied from a separate battery from that used for engine start. Voltage drops below 10 V, and starter motor transients, can cause the equipment to reset. This will not damage the equipment, but may cause the loss of some information and may change the operating mode.
- Raymarine specified cables are used. Cutting and rejoining these cables can compromise EMC performance and must be avoided unless doing so is detailed in the installation manual.
- If a suppression ferrite is attached to a cable, this ferrite should not be removed. If the ferrite needs to be removed during installation it must be reassembled in the same position.

Suppression Ferrites

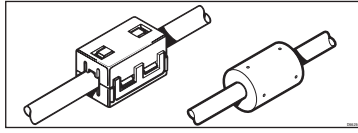

The illustration shows typical cable suppression ferrites used with Raymarine equipment. Always use the ferrites supplied by Raymarine.

Connections to other equipment

If your Raymarine equipment is to be connected to other equipment using a cable not supplied by Raymarine, a suppression ferrite **MUST** always be attached to the cable near to the Raymarine unit.

Where should the Display unit be located?

Your E-Series display can either be flush-mounted or mounted using the trunion bracket supplied.

Before you install the display, plan its installation, considering:

- **Convenience:** The contrast and colors seen on all Liquid Crystal Displays (LCD) vary slightly with viewing angle and are best viewed perpendicular to the display. The mounting location should be easily accessible to allow operation of the front panel controls. Avoid installing where excessive reflection will occur in normal use.
- **Access:** There must be sufficient space behind the display to allow cable connections to the rear panel connectors, avoiding tight bends in the cables.
- **Interference:** The selected location should be far enough away from devices that may cause interference, such as motors, generators and radio transmitters/receivers (see EMC Guidelines).
- **Magnetic compass:** Mount the display at least 3ft (1m) away from a magnetic compass.
- **Cable runs:** The display should be mounted as near as possible to a Direct Current (DC) power source. All cables should be adequately secured, protected from physical damage and excessive vibration. Avoid running cables through bilges or doorways, or close to moving or hot objects.
- **Environmental:** The display should be protected from physical damage and excessive vibration. Although the display unit is waterproof, it is good practice to mount it in a protected area away from prolonged and direct exposure to rain and salt spray. The rear of the display should be in a well ventilated space to ensure air circulation to the rear of the unit.

EMC Conformance

Always check the installation before going to sea to make sure that it is not affected by radio transmissions, engine starting etc.

Chapter 2: System Integration

Introduction

This chapter provides an overview of system integration, you may find that your system does not use all the protocols or contain all the instrumentation that is described in it. However it is hoped that the information supplied will help in your understanding of how systems can be integrated and used successfully.

2.1 What is System Integration?

System integration enables various instruments and displays to communicate with each other and use the collected data to increase the functionality of the system.

This data exchange is only possible if the data gathering is accurate, and transfer between instruments is fast and accurate.

Fast and accurate data transfer is achieved by using a combination of the following data protocols:

- SeaTalk.
- SeaTalk².
- National Marine Electronics Association (NMEA)0183.
- NMEA 2000.
- SeaTalk High Speed.

When two or more E-Series Displays are networked, all shared data can be viewed on any display.

What is SeaTalk?

SeaTalk

The SeaTalk protocol enables compatible instruments to be connected to a simple network by way of a single cable carrying power (12 volts, 150 mA) and data in/out, without a central processor.

Additional instruments and functions can be added to a SeaTalk system, simply by plugging them into the network. SeaTalk equipment can also communicate with other non-SeaTalk equipment via the NMEA 0183 standard, provided a suitable interface is used.

SeaTalk²

SeaTalk² is an enhanced replacement for SeaTalk and is a proprietary extension to NMEA 2000 and the proven CAN bus technology. It enables other Raymarine SeaTalk²

devices to talk to each other, whilst maintaining near transparent NMEA 2000 compatibility.

What is SeaTalk High Speed?

SeaTalk High Speed is designed to provide a 'plug and play', ethernet based marine network. It supports up to 8 nodes e.g. 7 displays and a DSM300, which can be connected to a compatible device, display, DSM etc. to give you access to all radar, fishfinder, chart cartridge and instrument data, waypoints, routes, tracks and navigation information held on the system.

What is NMEA?

NMEA 0183

The NMEA 0183 Data Interface Standard was developed by the National Marine Electronics Association of America. It is an international standard to enable equipment from many different manufacturers to be connected together and share information.

The NMEA 0183 standard carries similar information to SeaTalk. However it has the important difference in that one cable will only carry information in one direction. For this reason NMEA 0183 is generally used to connect a data receiver and a transmitter together, e.g. a compass sensor transmitting heading to a radar display.

This information is passed in 'sentences', each of which has a three-letter sentence identifier. It is therefore important when checking compatibility between items that the same sentence identifiers are used:

- VTG - carries Course and Speed Over Ground data.
- GLL - carries latitude and longitude.
- DBT - carries water depth.
- MWV - carries relative wind angle and wind speed data.

NMEA 2000

NMEA 2000 offers significant improvements over NMEA 0183, most notably in speed and connectivity. Up to 50 units can simultaneously transmit and receive on a single-physical bus at any one time, with each node being physically addressable.

The standard was specifically intended to allow for a whole network of marine electronics from any manufacturer to communicate on a common bus via standardized message types and formats.

2.2 Compatibility

Radar Scanners

CAUTION: Radar Scanners, Cables & Installation

Information on radar scanners, cables and their installation contained in this handbook supersedes that contained in the Pathfinder Radar Scanner Handbook, Document No. 81154_6, dated 11th March 2002.

To achieve full radar compatibility with your E-Series Display, your Raymarine radar scanner may require upgrading. Please check the list below to see if this upgrade is required.

The scanner serial number can be found on a label attached to the scanner casing:

Scanner type	Serial Number	Compatibility
2Kw Radome	1220000 and below	Not compatible
	1220001 - 0530157	Upgrade required
	0530158 and above	Fully compatible
4Kw Radome	1220000 and below	Not compatible
	1222001 - 0530246	Upgrade required
	0530247 and above	Fully compatible
4Kw Open Array	1030000 and below	Not compatible
	1030001 - 1230143	Upgrade required
	1230144 and above	Fully compatible
10Kw Open Array	0430000 and below	Not compatible
	0430001 and above	Fully compatible

The Open Array system will also require a split pedestal cable.

If your radar scanner requires upgrading, please contact your local Raymarine dealer for full information.

Digital Sounder Module

Important:

In order for your Digital Sounder Module (DSM) to be compatible with your E-Series display, you will need a DSM300 (Part no. E63049).

Media storage cards

Navionics Chart cards

To use your E-Series Display as a navigation aid, charts with detailed information for the area you wish to navigate are required. The charts are available on Navionics® Chart cards.

A chart card provides an appropriate level of detail and scale for a given geographic area.

To obtain suitable Navionics Chart Cards, contact your local dealer or visit the Navionics web sites: **www.navionics.com** or **www.navionics.it**.

Alternatively, in North America call Navionics toll-free on **1-800-848-5896**.

Outside of North America, contact your local dealer or call Navionics SpA on tel: **(+39) 0584 961696** or fax: **(+39) 0584 961309**.

CompactFlash cards

It is possible to archive or transfer information to and from your E-Series display and other compatible instruments using CompactFlash cards. To achieve the best results it is recommended that SAN DISK® CompactFlash cards are used.

2.3 Functionality

For full functionality of the displays the following position and heading data is required:

- **Orientation** - requires heading data derived from a suitable compass, for the radar to operate in North Up or Course Up mode and the chart to operate in Course Up and Head Up modes.
- **Man Overboard (MOB)** - requires heading and speed data. Alternatively, use speed over ground (SOG) and course over ground (COG) derived from the same source as position data (GPS).
- **Mini Automatic Radar Plotting Aid (MARPA) and radar/chart overlay functions** - requires accurate heading data. MARPA functionality is provided if SOG and COG are also available. Increased accuracy will be obtained by using fast heading data from a suitable compass, Smart heading sensor or compatible Raymarine autopilot.
- **Chart display** - requires position data (GPS).

2.4 How is an E-Series integrated?

You can integrate:

- A single E-Series display.
OR:
- Connect two E-Series displays or an E-Series display and a DSM 300 via a crossover coupler.
OR:
- Connect two or more E-Series displays and a DSM300 if required via a SeaTalk High Speed switch to form a network.

The diagrams that follow show three suggested set ups. These are not however the only possible combinations:

Single display system

This simple system incorporates a single E-Series display with a DSM 300 and radar.

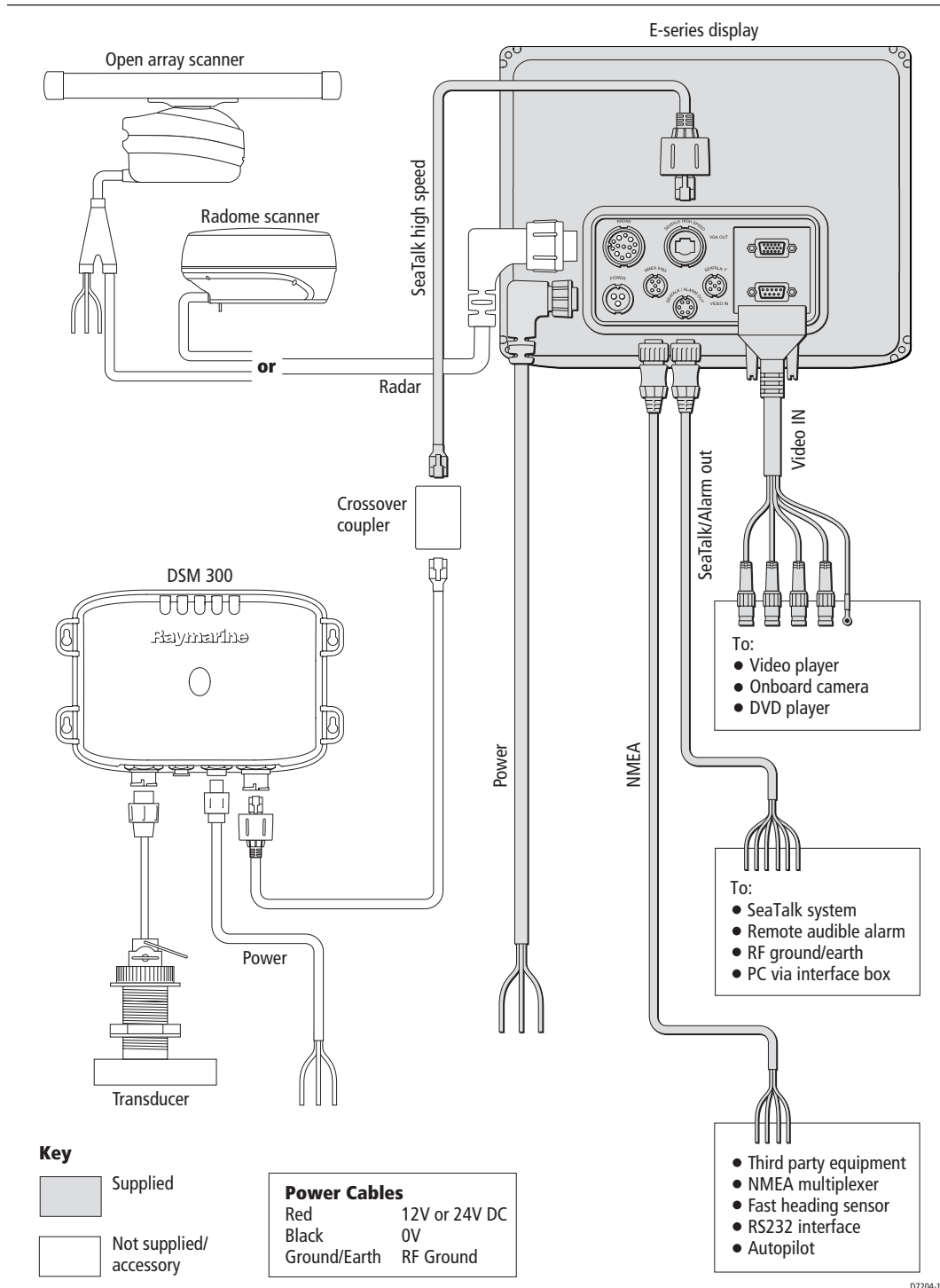

Networking E-Series Displays

You can connect two or more E-Series Displays to create a network. This will enable you to input, view and maintain data across all your Displays and enable multiple SeaTalk instruments to communicate with one another.

When you are installing a network of E-Series Displays you should note the following:

- One display will act as the master, into which all SeaTalk/SeaTalk² connections should be made.
- If you connect the master display to all other displays in the system via SeaTalk or SeaTalk², you will negate the need to unplug and reconnect cabling if the master becomes redundant.
- The bridging of data from SeaTalk/SeaTalk² only occurs at the master. You cannot therefore have additional networks connected to additional E-Series Displays. You can however connect multiple NMEA inputs.
- As it is not possible to view a video image across the network, you should connect the Video In cable to the display on which you wish to view the image.

The following two pages detail a simple E-Series Networked System with two E-Series displays and no DSM and a more advanced, multiple node system incorporating two (or more) displays and a DSM 300.

A typical two node system incorporating two displays

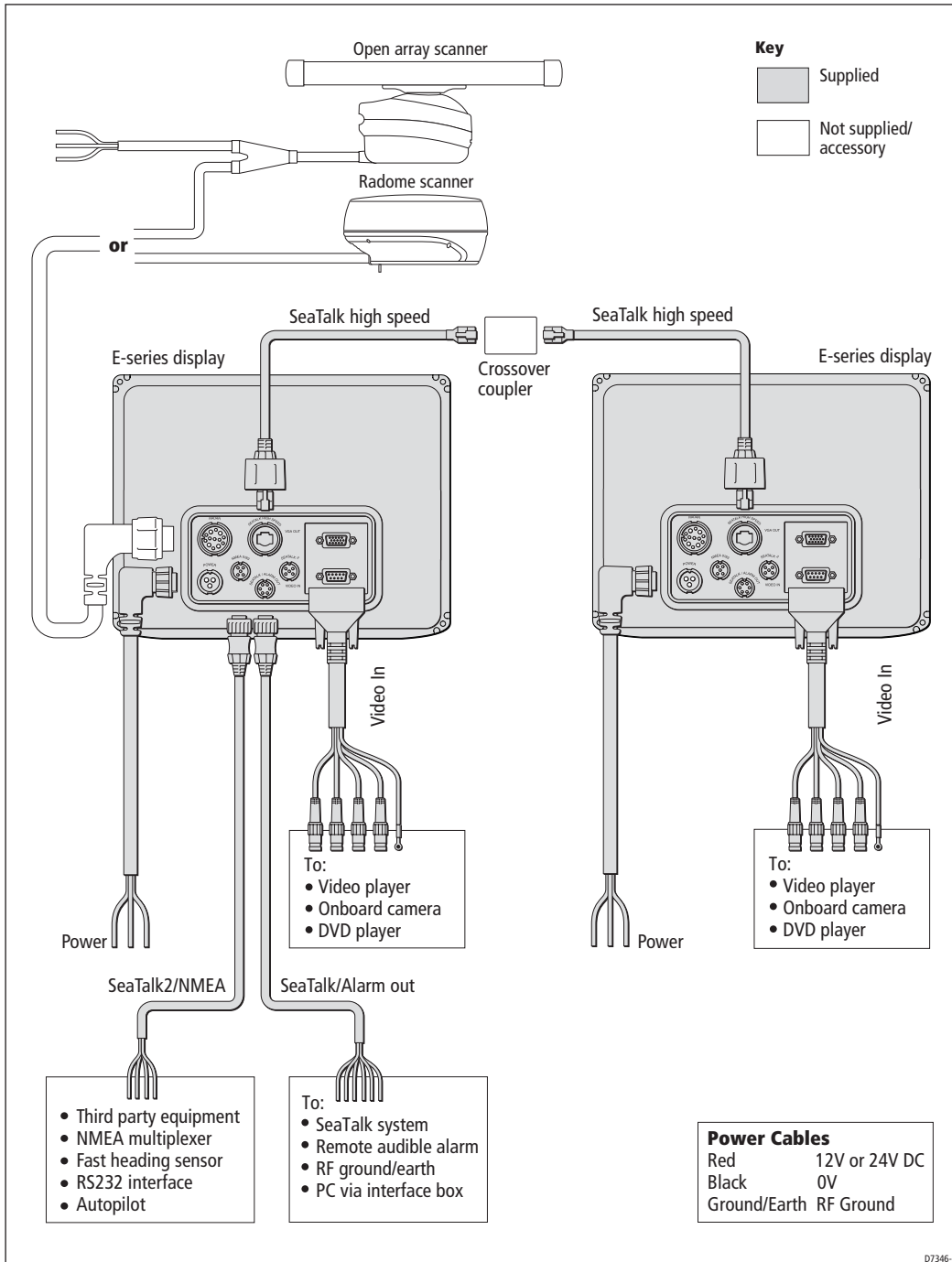

D7346-1

An example of a three (or more) node system

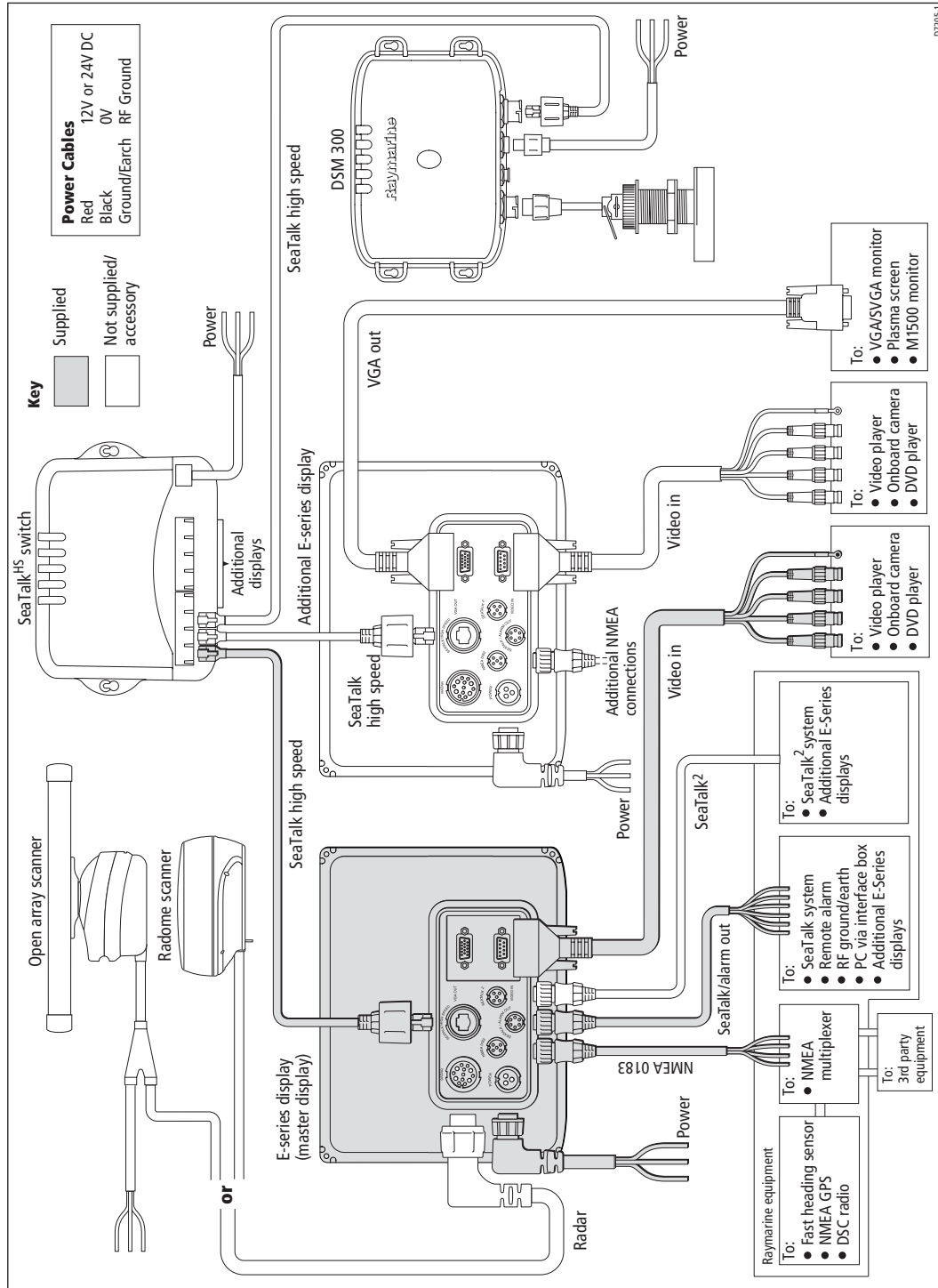

Chapter 3: Installation

CAUTION:

Please ensure that you have read Chapter 1: Preparation for installation before proceeding.

CAUTION: Radar Scanners, Cables & Installation

Information on radar scanners, cables and their installation contained in this handbook supersedes that contained in the Pathfinder Radar Scanner Handbook, Document No. 81154_6, dated 11th March 2002.

Introduction

This chapter provides instructions for installing your E-Series Display. You may find that your system does not use all the protocols or contain all of the instrumentation that is described.

3.1 How can the display unit be mounted?

**CAUTION: Installation**

Make sure there are no hidden electrical wires or other items behind the selected location before proceeding.

Make sure there is sufficient rear access for mounting AND cabling.

The display unit is waterproof to CFR 46 and can be installed either above or below deck using either the trunnion bracket or by flush mounting it in a suitable position.

Mounting the Display on the trunnion bracket

The display unit can be fitted on a dash, chart table, bulkhead or deckhead, using the trunnion bracket:

You should fit the trunnion bracket as follows:

1. Mark the location of the trunnion bracket screw holes on the chosen mounting surface.
2. Drill pilot holes for the screws using a suitable drill, taking care that there are no cables or anything that may be damaged behind the surface.
3. Use the 5 bolts supplied (together with the washers and nuts) to securely attach the bracket.
4. **Before** attaching the display unit to the bracket:

- i. Locate the front cover clip-on over the front of the display - see *page 20*.
 - ii. Check that the buttons have passed through the cover and are free to operate. It is suggested that you use your thumb or forefinger in a circular motion to do this.
5. Attach the display unit into the trunnion bracket, adjusting the unit to the required angle for clear vision.
 6. Tighten the trunnion knobs.

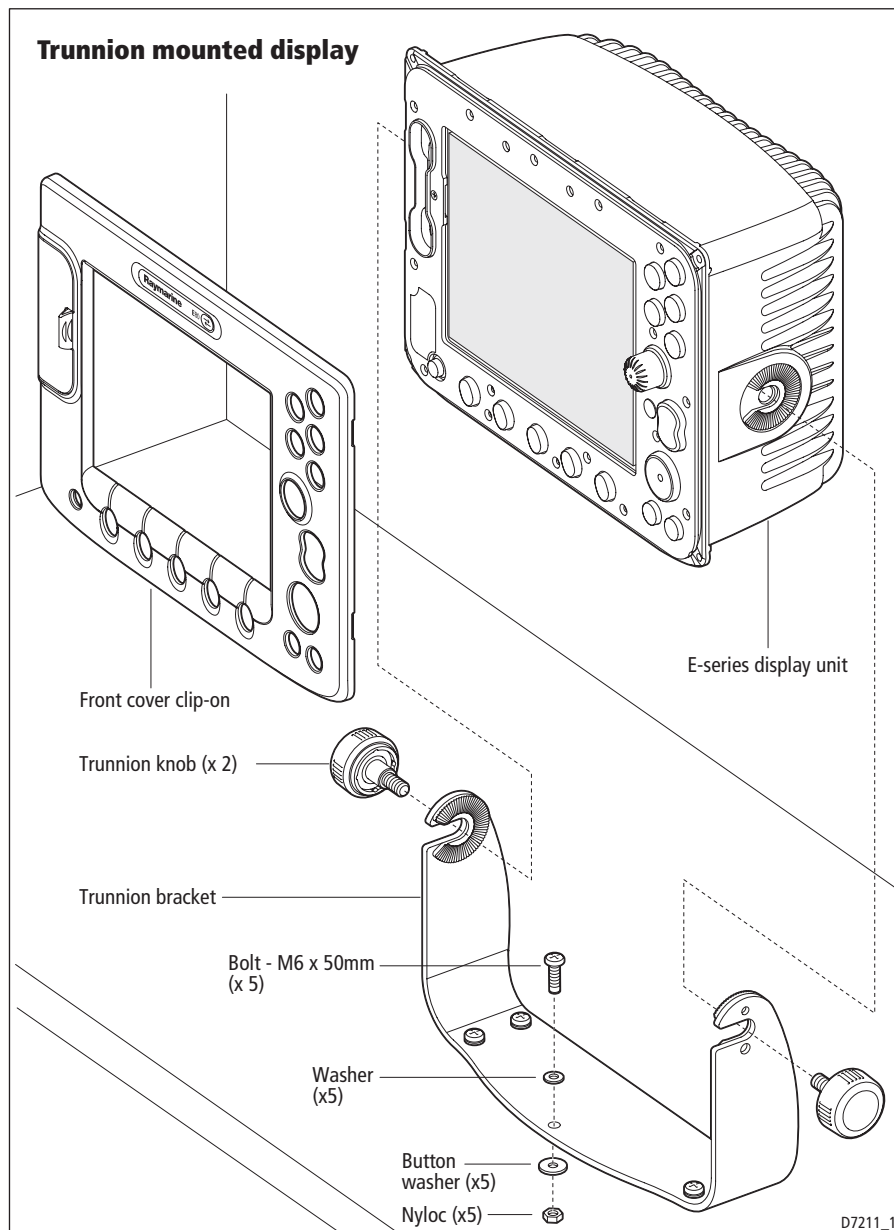

Flush mounting the Display

You should flush mount your display as follows:

1. Check the selected location for the unit. A clear, flat area with suitable clearance behind the unit, is required.
2. Fix the appropriate template - E80 or E120, supplied in the document wallet, to the selected location, using self-adhesive tape.
3. Using a suitable hole saw, the size is indicated on the template, make a pilot hole in each corner of the cut-out area.
4. Using a suitable saw, cut along the inside edge of the cut-out line.
5. Ensure that the unit fits into the area that has been cut out and then file around the cut edge until smooth.
6. Drill four 4.5 mm holes as indicated on the template, to accept the securing bolts.
7. Remove the backing tape from the panel seal and place the seal onto the display unit and press firmly onto the flange.
8. Connect all the cables that are in use to the rear of the display, avoiding tight bends.
9. Slide the unit into the console and secure using the bolts supplied.
10. Fit the front cover clip-on onto the display - see *page 20*.

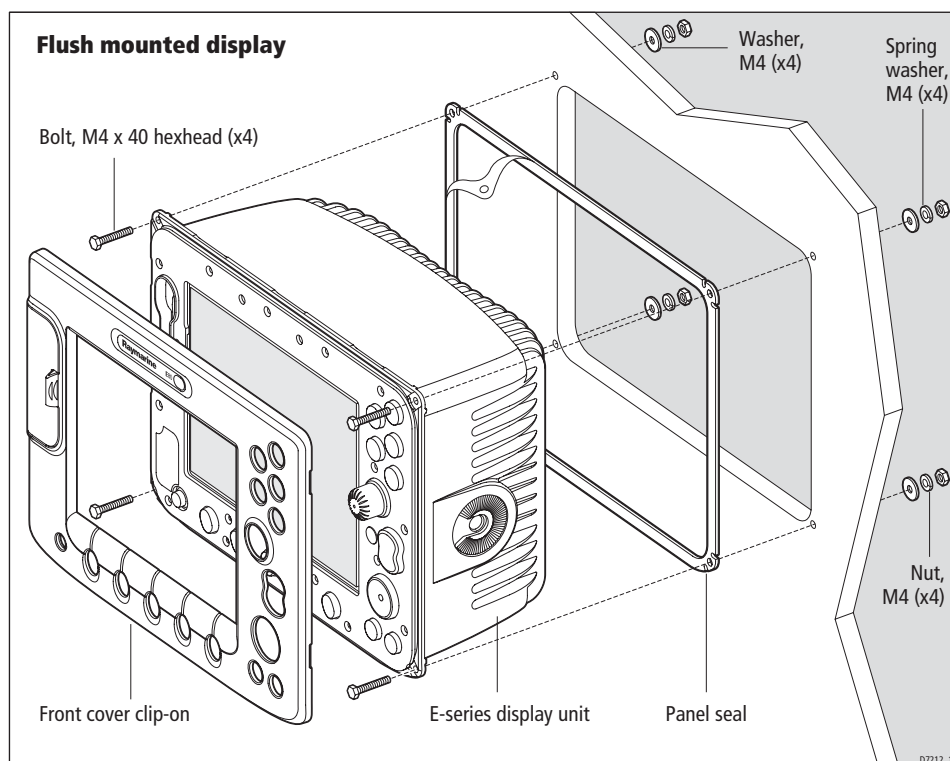

How is the front cover clip-on attached to the display?

The front cover clip-on is attached as follows:

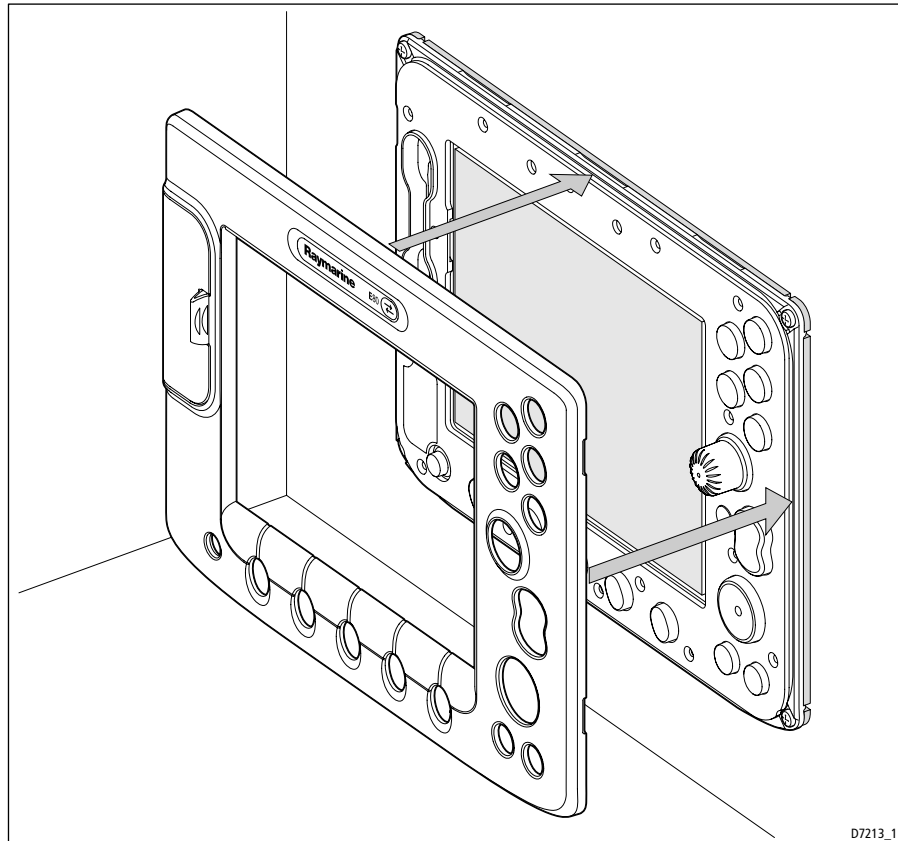

D7213_1

1. Carefully lift one edge of the screen protection film, so that it is accessible for removing when unit installation is complete.
2. Place the front cover clip-on onto the E-Series Display, ensuring that the locking lugs (located at the bottom edge of the covers) are latched into position.
3. Ensure that the control buttons pass through their respective openings.
4. Apply firm but even pressure to the cover along the:
 - i. outer edges - work from the sides upwards and then along the top edge, to ensure that it clips securely into position.
 - ii. inner edges - particularly along the chart card door edge, to ensure that the clip-on sits flat.
5. Check that all control buttons are free to operate.

How do I remove the front cover clip-on?

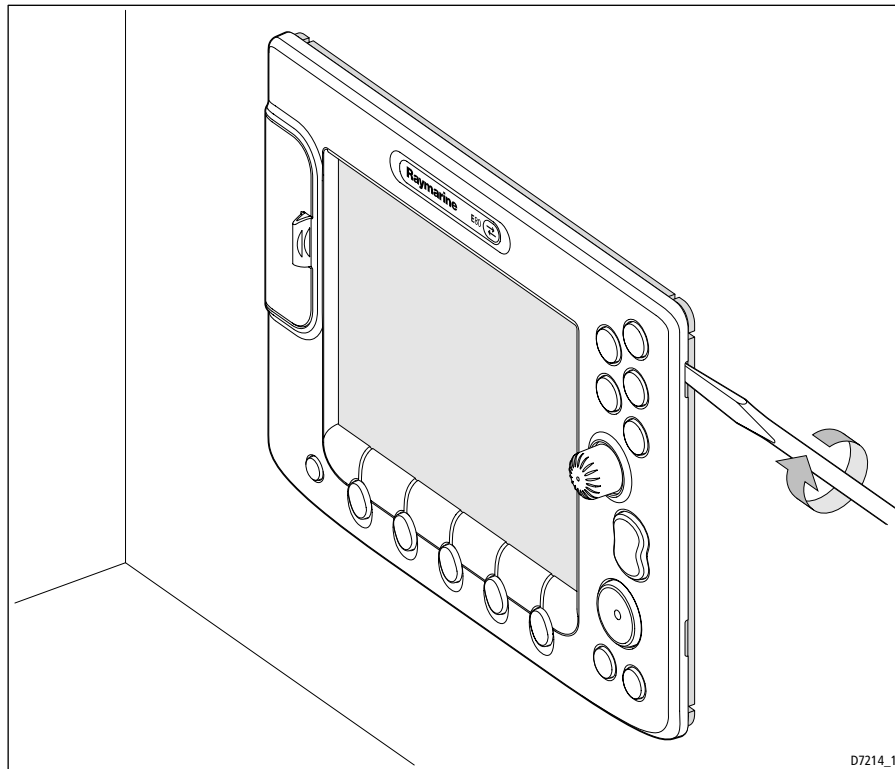

To remove the clip- on front cover:

1. To prevent damaging your dash or placing undue strain on the trunnion bracket, remove the unit from its mounting before proceeding. If you have flush mounted your Display and cannot readily gain access to the rear of the unit, protect the dash and proceed with caution.
2. Using a flat-bladed screwdriver placed in the aperture at the top right of the front cover clip-on, gently twist it to release the top clips.
3. Working from this corner, free the clips along the top edge of the display **by hand**, then work towards the bottom edge. Taking care to ensure that the control buttons pass through the clip-on. **DO NOT** lever along the top edge.
4. Carefully free the locating clips at the bottom of the clip-on by lowering it away from the unit - **DO NOT USE A SCREWDRIVER FOR THIS AS IT WILL DAMAGE THE CLIPS.**
5. Remove the clip-on front cover from the display.

3.2 Cables

This section details how to instal and connect all the relevant cables to your E-Series Display.

Siting and securing cables

When installing system cables, please note the following:

- All cables should be adequately secured, protected from physical damage and exposure to heat. Avoid running cables through bilges or doorways, or close to moving or hot objects.
- Acute bends must be avoided.
- Where a cable passes through an exposed bulkhead or deckhead, a watertight feed-through should be used.
- Secure cables in place using tie-wraps or lacing twine. Coil any extra cable and tie it out of the way.
- **Do not pull cables through a bulkhead or deckhead using a cord attached to the connector as this could damage the connections.**
- **Do not remove the SeaTalk High Speed blanking plug** from the rear of the display **until** such time as you are ready to connect the cable. Failure to adhere to this, may result in the ingress of water and permanent damage to the display.

What cables do I need to connect?

To ensure that your E-Series Display functions correctly, you will need to connect the following cables:

- Power cable.
- SeaTalk/Alarm Out cable (if SeaTalk system connected).
- NMEA cable (if third party equipment, NMEA multiplexer, fast heading sensor, RS232 interface or course computer fitted).
- SeaTalk² cable (if Sea Talk² system connected).
- SeaTalk High Speed cable (if a DSM or second display is fitted).
- Video In cable (if a video player, on-board camera or DVD player fitted).
- Radar cable (not supplied).
- VGA Out cable (if an M1500 monitor or additional screen is fitted).

How are the cables connected to the display?

The cable connections are located on the back of the display unit. All cables can be connected **prior** to mounting the unit on the trunnion bracket.

CAUTION: Do not remove the SeaTalk High Speed blanking plug from the rear of the display until such time as you are ready to connect the cable. Failure to adhere to this may result in the ingress of water and permanent damage to the display.

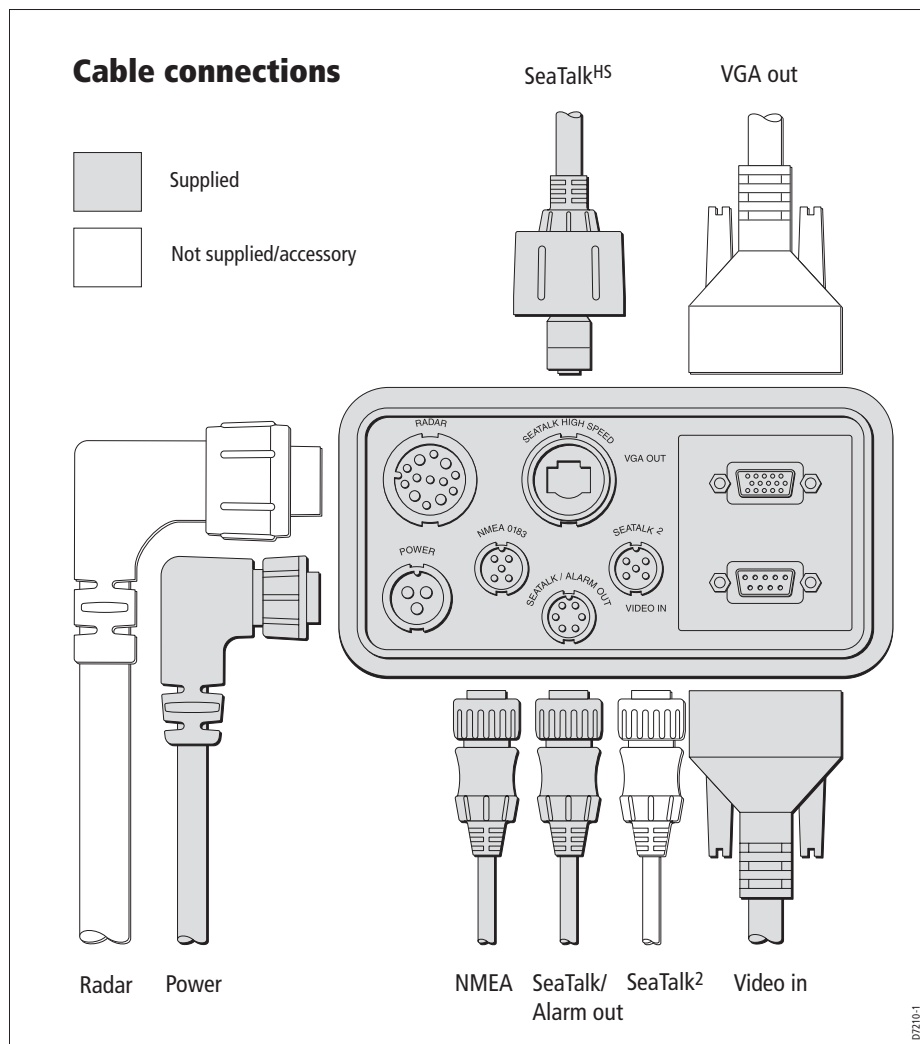

Note: For details of what is connected to each of these cables please refer to the diagrams on page 12, page 14 and page 15.

How do I use the cable splicers?

The cable splicers are used to make the connections between the cables easy and secure, without removing insulation from cable tails.

To use these connectors:

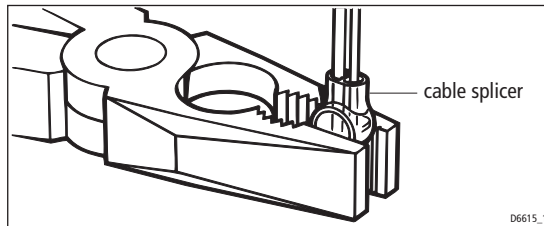

1. Place the wires to be joined into the connectors, ensuring correct polarity and that the wires are pushed fully home.
2. Using a pair of pliers, crimp the connector bulb together.
3. Check that a secure connection has been made.
4. Ensure that the cables are secured in a suitable position to prevent the join being placed under strain.

Power cable

The E-Series Display is intended for use on boats' DC power systems rated at 12v or 24v.

The power connection should be made at either the output of the battery isolating switch, or at a DC power distribution panel. Raymarine recommends that power is fed directly to the display and scanner via its own dedicated cable system and MUST be protected by a thermal circuit breaker or fuse, installed close to the power connection.

This cable is supplied ready for connecting to your boats DC power supply, with a length of screen exposed before the positive and negative wire tails. This screen should be clamped to your boat's earth/ground with a saddle clamp, as shown below:

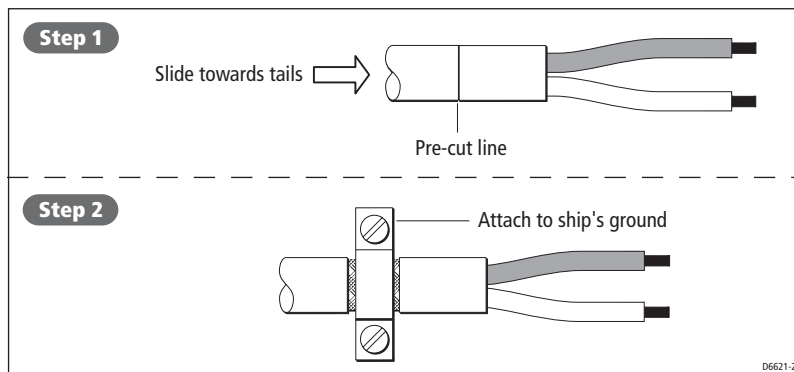

Extension cable

If an extension power cable is required, please note the following:

- The wire gauge used may be affected by the scanner type.
- To minimize voltage drops, use large gauge cable.
- Use the supplied power cable to connect to the display unit. Then use a suitable connector block to connect the free end to the extension cable, taking particular care to ensure the correct polarity. The supplied power cable has a cross section of 10 mm.

Fuse ratings

- Without a scanner - use a 6.3 amp anti-surge fuse.
- With a scanner - refer to the fuse notification in the scanner handbook.

SeaTalk/Alarm out cable

The SeaTalk cable is supplied with insulated tails. These should be connected to your existing equipment using either the cable splicers supplied or by using a standard screw terminal block.

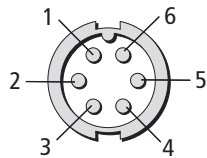
Function	Color	Pin no.	Rear unit view
SeaTalk power	Red	1	
SeaTalk return	Black	2	
SeaTalk data	Yellow	3	
Alarm out (open collector)	White	4	
Alarm return	Brown	5	
Screen (RFground/earth)	Unsheathed/Drain wire	6	

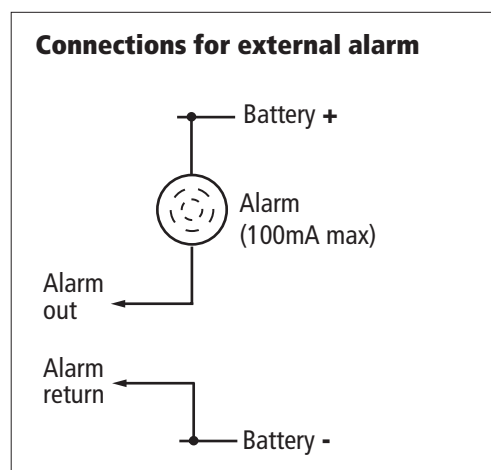

NMEA 0183 cable

The NMEA 0183 cable is supplied with exposed wire connecting tails. These should be connected to your existing NMEA instruments using suitable connector blocks:

Function	Color	Pin no.
NMEA Input (-ve) common	Green	1
NMEA Input (+ve)	White	2
NMEA Output (+ve)	Yellow	3
NMEA Output (-ve) common	Brown	4
Not connected	Screen	5

SeaTalk High Speed cable

CAUTION: Water ingress

Failure to adhere to the following may result in the ingress of water and permanent damage to the display:

- **Do not remove the SeaTalk High Speed blanking plug from the rear of the display until such time as you are ready to connect the cable.**
- **When inserting the cable, ensure that it is clicked AND then turned, in order to lock it into place and create a watertight connection.**

How the SeaTalk High Speed cable connects depends on whether you are integrating your E-Series Display into a two node, or 3-or-more node system.

Two node system

Connect the cable by way of the crossover coupler to either:

- The display unit and a DSM300.
- OR
- Two displays units.

3 or more node system

Connect the display unit(s) to the SeaTalk High Speed Network switch (E55058).

Note: *Please refer to page 11 for diagrams of these two systems.*

Video In cable

Your E-Series display will support on-board cameras, DVD or video players etc. using composite or S-Video source type. If you have an E-Series network, you will need to connect the input source to the individual display on which it is to be viewed as video images cannot be seen across the SeaTalk High Speed network. Your display is supplied with a composite cable. If you require an S-Video cable, please order part no. E55062.

Composite source type

Use the supplied cable to connect up to 4 composite source inputs to your E-Series Display. The color of each connector defines the video number to which it configures within the Video Setup Menu:

- Black - Video 1
- White - Video 2
- Red - Video 3
- Green - Video 4

S-Video source type (not supplied)

If you wish to use S-Video source type, you will need to purchase an S-Video cable (Part no. E55062). You can connect 2 inputs using S-video to each E-Series Display. The color of each connector defines the video number to which it configures within the Video Setup Menu:

- Black/White - Video 1/2
- Red/Green - Video 3/4

For further information on setting up your video application, please refer to the Video chapter of the Reference Manual.

VGA Out (not supplied)

Use this cable to connect to VGA/SVGA monitor, plasma screen television or M1500 monitor. Please ensure that any equipment that you connect conforms to the following:

Display	Resolution	Refresh rate
E120	800 x 600	56 Hz
E80	640 x 480	60 Hz

Note: Please refer to page 4 for details of this accessory.

SeaTalk² (not supplied)

Use this cable to connect to third party equipment or SeaTalk² instruments.

If your system networks two or more E-Series displays, you should ensure that the SeaTalk 2 connection is made to the display that you have defined as your master unit.

Note: Please refer to page 4 for details of this accessory.

Radar cable (not supplied)

Having ensured that the radar scanner you are using is compatible with the E-Series Display (see "Compatibility" on page 9), the cable should be connected as follows:

Connecting to a Radome

If you are using a radome this can be powered through the display. Just run your cable and connect it to the radome and the display.

If the existing cable is too short, please order from the following:

Part No.	Cable length	Weight	Radome power output
E55065	15m	Heavy	2Kw or 4 Kw
E55066	25m	Heavy	2Kw or 4 Kw
E55067	10m	Light	2kw
E55068	15m	Light	2kw

Connecting to an open array

If you are using an open array, this cannot be powered through the display. You will need to purchase a split pedestal cable:

...for new installations

Part No	Description
E55063	15m Split pedestal cable
E55064	25m Split pedestal cable

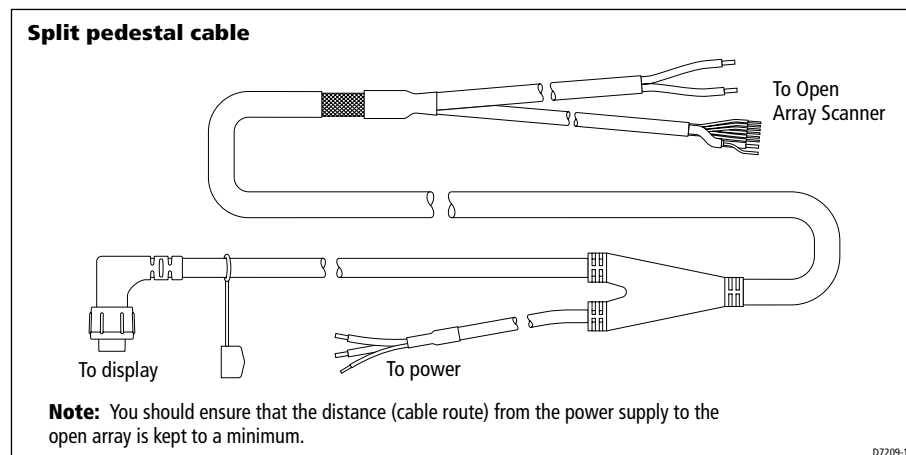

The array and the display should be connected using the split pedestal cable as shown:

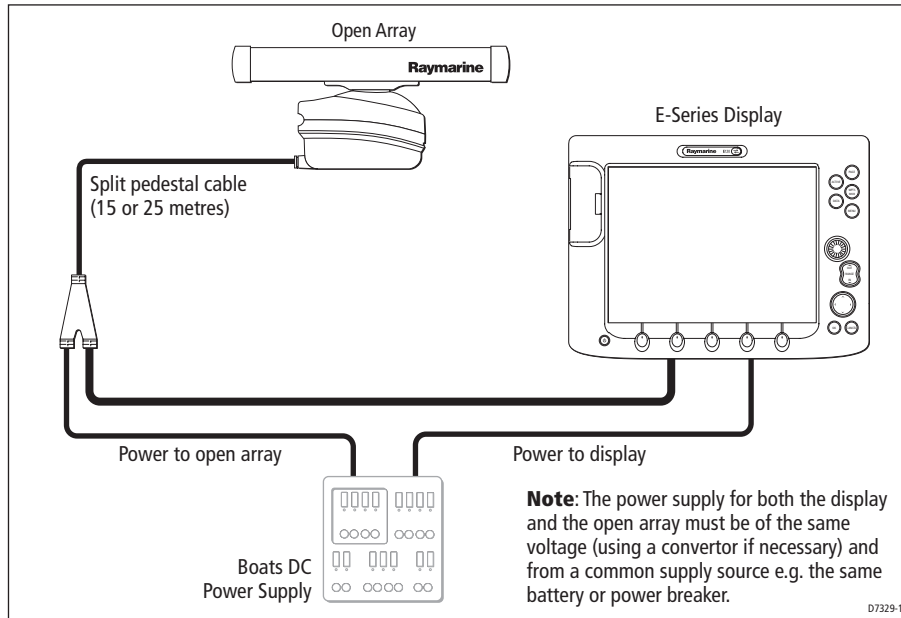

... to replace a Raymarine Pathfinder Display

Part No	Description
E55069	2.5m Pedestal adaptor cable

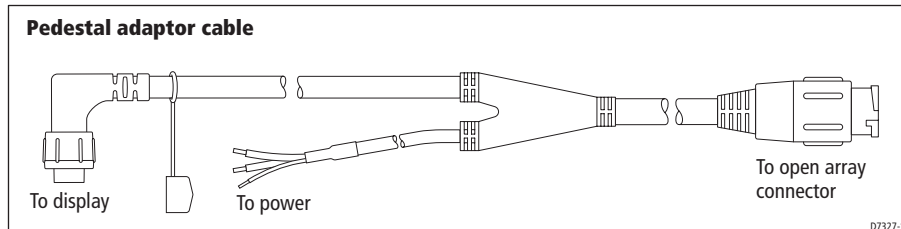

The array and the display should be connected using the pedestal adaptor cable as shown:

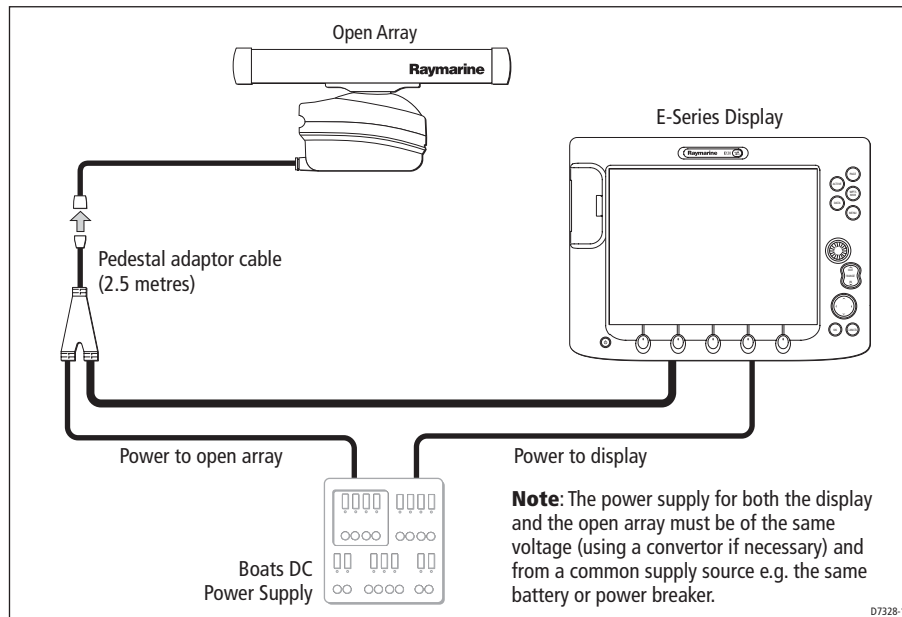

Chapter 4: Commissioning the system

4.1 Introduction

This chapter details the commissioning of your E-Series Display and includes the following:

- Required input.
- Pre-start checks.
- Initial power on procedure
- Radar checks and alignment.
- Chart application checks.
- Fishfinder checks.
- SeaTalk High Speed checks.
- Video in/out.

4.2 What input does my E-Series require?

The table below details the data required by each application of your E-Series:

		Application						
		Radar	Chart	Fishfinder	CDI	Digital Instruments	Engine monitor	Video
Data	Multi-media card		*					
	GPS		*	*	*	*		
	Datum		*					
	Compass, autopilot or smart heading sensor	*	*			*		
	Scanner	*						
	DSM 300 only			*		*		
	Instruments					*		
	Video input							*

- Notes:** (1) For full details of scanner compatibility see page 9. If you are still unsure as to your scanner's suitability, please refer to an authorized Raymarine dealer.
- (2) Engine output from a compatible engine manufacturer is also required. See Raymarine.com for latest compatibility information.

4.3 Pre-start checks

Before you perform any functional tests, please carry out the following pre-start checks:

Radar

- Check that the scanner has been installed in accordance with the instructions contained in the relevant handbook. All securing bolts should be fully tightened and any mechanical locking arrangements, as specified, are in place.
- Ensure scanner and power connections have been made.
- If an open array is fitted, ensure that power is connected through a split cable to a suitable circuit breaker and that the power switch located on the pedestal is set to **ON**.
- All connecting wires are secured and protected as necessary.

Note: *If you are the boat's owner and have installed the radar system, ask an authorized Raymarine dealer to check the installation before going to sea.*



WARNING: Electromagnetic energy

The radar scanner transmits electromagnetic energy. Ensure that the scanner has been installed according to the recommendations in the relevant scanner handbook. Ensure all personnel are clear of the scanner, before switching to transmit mode.

Fishfinder

Ensure that the transducer cable is inserted and the bayonet connector locked onto the DSM 300.

GPS

Check that the GPS has a clear view of the sky and is not obstructed e.g. by buildings, bridges or other equipment fitted on-board.

4.4 Initial power on procedure

Once you have conducted the pre-start checks you are ready to start the display:



1. Press the **POWER** button until the introductory logo is displayed:
 - The keys light up and after a few seconds a navigation warning is displayed.
 - If you have networked two or more E-Series displays, you will also hear an alarm and be asked to select the repeater displays. Press SET AS REPEATER on the appropriate Display(s).
 - At this time the radar scanner (if fitted and powered) is checked for compatibility with the display. An error message is displayed if the scanner is incompatible.
2. Read the warning and then press **OK** to remove it. The Select Page Set screen is displayed:

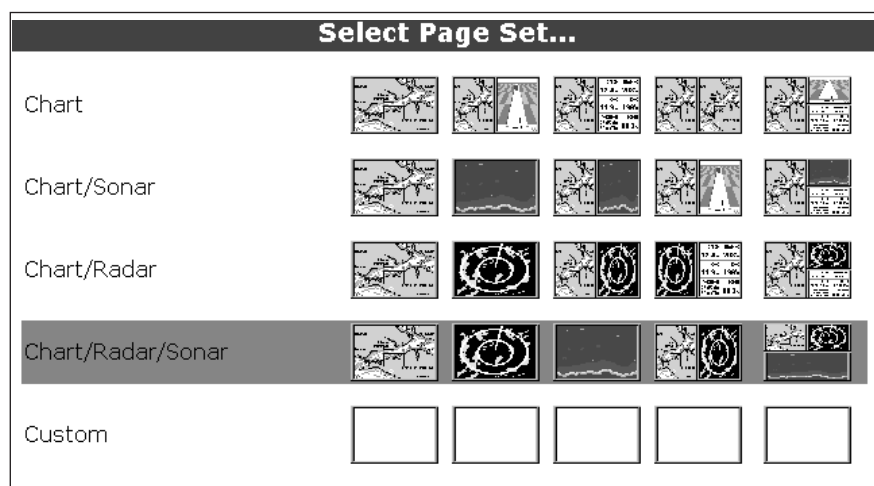

3. Use the trackpad to select the required page set and then press **OK**.

You are now ready to test that your system is receiving the necessary data to run all the required applications.

4.5 How do I test and align the radar?

Your E-Series display is part of an integrated system. Raymarine strongly advise that you test and align the radar **before** connecting to other systems.

To test and align the radar you must first select a radar application. With the Select Page Set screen displayed (see previous section):

1. Press **OK** to select the highlighted page set.
2. Press **PAGE**. The currently selected page set is represented on the soft keys.
3. Press the corresponding soft key to display a full window radar application.
4. The scanner warm-up countdown commences. This will take approximately 70 seconds.

Note: *If your scanner is incompatible, a message is displayed. If this is the case, you will be unable to proceed further with testing and aligning the radar. Refer to Important Information - Radar Scanners at the front of this handbook.*

Radar transmission check

With a radar application active, check the transmission to the scanner as follows:

1. Press the **RANGE** button and ensure that the radar range adjusts accordingly.
2. Check that all the following information is displayed:
 - In the status bar - the range, orientation, motion mode and range ring spacing
 - In the data bar - a turning radar status icon and vessel position data.

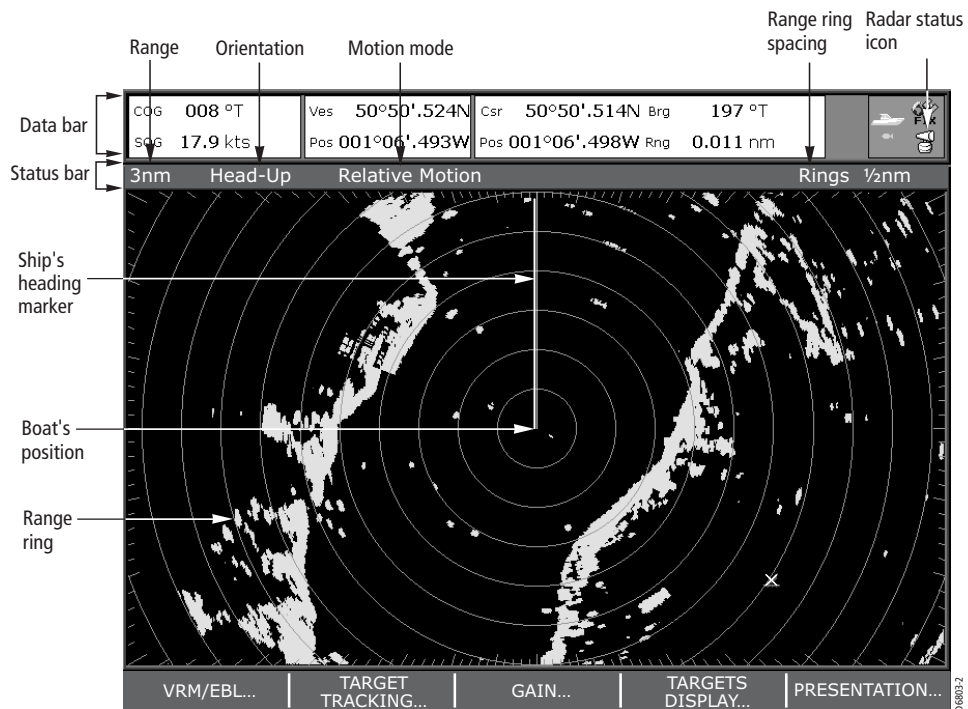

Radar alignment checks

You should check the bearing and display timing alignment to ensure that an accurate picture is shown.

Bearing alignment

Adjusting the bearing alignment ensures that targets appear at the correct bearing relative to your boat's bow. You need to select a visible target of known bearing that is displayed on the radar, and then adjust the radar set up as necessary until the correct bearing reading is obtained.

You can carry out a bearing alignment in two ways:

... with your boat moored

To use this method you will need a hand bearing compass:

1. Visually identify a suitable target, such as a buoy that can be seen towards the edge of the radar screen. Typically, this will be on the 1.5nm range.
2. Determine the accurate bearing of the target relative to your boat's bow using the hand bearing compass. To do this subtract your boat head bearing from the target visual bearing, these examples may help:

Example 1

Visual bearing (a) = 065° M

Ships head bearing (b) = 021° M

Relative bearing:

= (a) - (b)

= 065 - 021 = 044° R

Example 2

Visual bearing (a) = 030° M

Ships head bearing (b) = 042° M

Relative bearing:

= (a) - (b)

= 030 - 042 = -012

If answer is negative, add 360° =

012 + 360 = 348° R

3. From the primary radar soft keys, press VRM/EBL.
4. Toggle the VRM/EBL soft key to ON. Adjust the EBL to your chosen target. If there is a difference between your calculated bearing and that shown for the EBL, there is an alignment error and you will need to carry out bearing alignment adjustment, See *"How do I adjust the bearing alignment?"* on page 35.

... with your boat under way

1. Align your boat's bow with the selected target.
2. Note the position of the target relative to the Ships Heading Marker (SHM) on the radar picture. If the target is not under the SHM, there is an alignment error and you will need to carry out bearing alignment adjustment. For details see below.

How do I adjust the bearing alignment?

1. If moored, move the EBL to calculate bearing.
2. With a radar application in the active window, press MENU. The Set Up menu is displayed.

3. With RADAR SET UP highlighted, use the trackpad (right) to display the RADAR SET UP menu.
4. Use the trackpad (up/down) to highlight and then the trackpad (right) to select BEARING ALIGNMENT. The menu is removed from the screen and the Bearing Alignment soft key is displayed.
5. Press the BEARING ALIGNMENT softkey.
6. Proceed as follows:
 - **If the boat is moored** - use the rotary control to place the selected target under the EBL.
 - **If the boat is under way** - use the rotary control to place the selected target under the SHM.
7. Press **OK**. The picture updates as the bearing alignment is adjusted.
8. To exit the menu, press **OK** or **CANCEL**.

4.6 How do I check the GPS?

The GPS is used to position your boat on the chart. You can set up your Global Positioning System (GPS) and check its status using the GPS status icons and the GPS Status page of the Setup menu.

To access the GPS Status page:

1. Press **MENU**. The Setup menu is displayed.
2. Highlight and then select GPS Status. The GPS Status dialog box is displayed e.g.

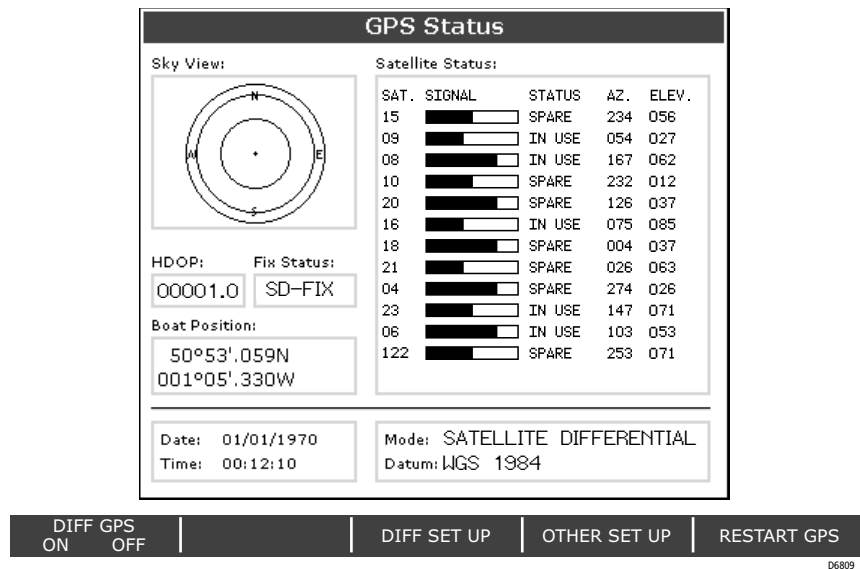

This screen provides, for each tracked satellite, the satellite number, a graphical signal strength bar, status, azimuth angle and its elevation angle from your vessel. The sky view graphic shows the position of these satellites.

Positional accuracy is dependent upon these parameters; in particular, the azimuth and elevation angles are used in a triangulation process to calculate your position. Horizontal Dilution of Position (HDOP) is a measure of this accuracy; a higher figure signifies a greater positional error. In ideal circumstances, the figure should be in the region of 1.0.



When a connection has been successfully made, the GPS status icon in the top right-hand corner of the screen reads FIX.



If NO FIX is displayed, please refer to the Troubleshooting section on *page 41*.

The option to select differential or satellite differential fix is dependent upon the capabilities of the attached GPS. If your boat is equipped with a Raymarine GPS, the Differential GPS can be switched on or off using the appropriate soft key.

4.7 How do I check the heading data?

If your display is connected to a compass, autopilot or fast heading sensor, your boat's heading will be displayed in the data bar. If heading data is not available your display can use COG data. This will however affect the operation of the following functions:

- overlay a radar image over your chart.
- orientate a radar image north-up.
- MARPA.

To linearize ('swing') your compass proceed as follows:

1. Press **MENU**.
2. Select the Compass Setup sub-menu.
3. Press LINEARIZE COMPASS and follow the instructions displayed on screen. When instructed to align heading, press the ALIGN HEADING soft key and then turn the rotary control **one click at a time** to fine tune the heading.

4.8 How do I check the Chart application?

For full functionality of chart applications, you need to ensure that position data is available at the display via SeaTalk, NMEA, SeaTalk² or SeaTalk High Speed. To use your chart as a navigation aid you will need a CompactFlash card (see *page 10*) with the appropriate level of detail for the geographic area that you wish to navigate.



Proceed as follows:

1. Without a chart card installed, press **PAGE**.
2. Select a full window chart application by pressing the associated key.
3. Zoom out with the **RANGE** button until the world map is visible.
4. To ensure that the display is responding to position data:
 - i. Press FIND SHIP.
 - ii. Check that the cursor is positioned over the boat symbol in the centre of the display.
5. Insert a chart card containing a suitable chart for the area in which you are located. Once inserted, the chart should redraw with the cartridge chart boundaries displayed.

Note: For details of how to insert a chart card, please refer to Section 2.7, *How do I use CompactFlash cards?* in the Reference Manual.
6. Zoom in with the **RANGE** button to check that chart data is being displayed.

4.9 How do I test the Fishfinder application?

For the fishfinder application to function it must be connected to a DSM 300. The status of your DSM is indicated by the boat/fish icon in the data bar (top right-hand corner of the screen):

DSM status icon	DSM status description
 (animated icon)	Successful connection to a DSM and transmitting.
 (static icon)	DSM connected but not transmitting.
 (greyed-out icon)	No DSM connected/recognized.

1. Press **PAGE** and select a full window fishfinder application.
2. Using the soft keys, check that individual settings change as they are selected.

Note: If your DSM is not being recognized by your display, please refer to the Troubleshooting section on page 41. Information about the status LED on the DSM300 is available in the DSM300 User Manual.

4.10 How do I test the video?

To ensure that the video application is operating you should open a video application on each display that is connected to a video input/output and check the following:

- **Video in** - check that an image is being displayed for each input.
Note: *If you are using S-Video rather than composite input, you will need to change the settings in the Video Setup Menu. Please refer to the Reference Manual for more details.*
- **Video out** - once you have attached the M1 500 or other monitor, check that the image from the E-Series unit is being displayed.

If 'No Signal' is displayed, check the video in and video out cable connections. If the problem persists, please contact Raymarine Technical Services (see *page 42*).

4.11 How do I test the SeaTalk^{HS} Switch connection?

To ensure that your SeaTalk^{HS} Switch is connected, you should check the following:

- The Switch should display a static green light (right) and a flashing green light (left) for each connecting port. If your switch is only displaying a left flashing light, data will be transferred but the connection will be at low speed.
- Open a radar, chart and fishfinder application window on all display units and check that the appropriate data is displayed throughout the network.

If you are not receiving any data, check the cable connections to the rear of the display and the SeaTalk^{HS} Switch. If the problem persists, please contact Raymarine Technical Services (see *page 42*).

4.12 How do I test instrument data?

To ensure that your system is receiving instrument data, you should check the following:

From SeaTalk or SeaTalk²

Open the digital instrument application and ensure all relevant data is displayed. If you are not receiving data, check cable connections.

From third party devices on NMEA 0183

Check that appropriate NMEA sentences are being sent from the third party device and on the E-Series Display. Open the digital instrument application and ensure all relevant data is displayed.

Chapter 5: Troubleshooting

Introduction

This chapter provides information on troubleshooting your Raymarine E-Series Display at installation, and how to get assistance from Raymarine.

5.1 How can I troubleshoot my Display?

All Raymarine products are, prior to packing and shipping, subjected to comprehensive test and quality assurance programs. However, if you cannot successfully install your Display unit, this section will help you to identify the most likely cause and show the corrective action required.

If, after referring to this section, you are still having problems with your Display, contact your local dealer, national distributor or Raymarine Technical Services Department for further advice.

Always quote the product serial numbers which are printed on the back of each unit.

Installation problem	Solution
Display does not function	<ol style="list-style-type: none"> 1. Make sure that the power supply cable is sound and that all connections are tight and free from corrosion. 2. Check relevant fuses. 3. Check power source is of correct voltage and sufficient current.
"Scanner not responding" message	<p>Check that the cable connecting the scanner to the radar display unit is securely connected and undamaged.</p> <p>If using split pedestal cable ensure power ON to scanner.</p>
"Invalid scanner software: Version xx.x, Version xx.x required"	Incorrect software version installed. Contact your local Raymarine dealer.
"Open array cannot be powered from the display"	Scanner not compatible with Display - refer to <i>Important Information</i> Section of this manual.
"Scanner hardware fault"	Scanner not functioning - <i>refer to the Maintenance & Troubleshooting</i> chapter of Reference Manual for more details.
The bearing displayed on the radar picture is not the same as the actual bearing	Perform the bearing alignment procedures described in <i>Chapter 4- System Tests and Alignment</i> of this manual.

5.2 How can I get Technical Support?

Raymarine provides a comprehensive customer support service, on the world wide web, through our worldwide dealer network and by telephone help line. If you are unable to resolve a problem, please use any of these facilities to obtain additional help.

World wide web

Please visit the Customer Support area of our website at: **www.raymarine.com/support**

For fastest support - 24 hours a day, seven days a week; go to the Frequently Asked Questions section. Most questions are answered here.

The website will also give you servicing information, e-mail access to the Raymarine Technical Support Department and details of the locations of Raymarine agents, worldwide.

If you don't have access to the world wide web, contact Technical Support where specialists are available to answer questions about installing, operating and troubleshooting all Raymarine products.

Help us to help you

When requesting service, please quote the following product information:

- Equipment type.
- Model number.
- Serial number.
- Software issue number

To access this information:

1. Press **MENU**.
2. Highlight and select System Diagnostics.
3. Highlight and select Software Services.
4. Highlight and select Unit Info. The Unit Info : Software Details screen is displayed giving full details of your particular unit together with its software.

How can I contact Raymarine in the US?

You can contact Raymarine in the US either using the Raymarine world wide web as detailed above or by calling one of the telephone numbers below.

Who do I contact for accessories and parts?

You can obtain many Raymarine accessories and parts directly from your authorized Raymarine dealer. However, if your dealer does not have the item you want, contact Raymarine Technical Services at:

1-800-539-5539 extension 2333, or
(603) - 881 - 5200

You can use these numbers Monday through Friday 0815 to 1700 Eastern Standard Time or Eastern Daylight Savings Time.

If you are not sure which item is appropriate for your unit, you should first contact the Technical Support Department at:

1-800-539-5539 extension 2444, or
(603)-881 -5200

to verify your requirements.

Who do I contact for product repair and service?

In the unlikely event that your Raymarine unit should develop a problem, contact your authorized Raymarine dealer for assistance. The dealer is best equipped to handle your service requirements and can offer timesaving help in getting your equipment back into normal operation.

If repairs cannot be obtained conveniently, obtain product service by returning the unit to:

Raymarine Product Repair Center
22 Cotton Road, Unit D,
Nashua,
NH 03603-4219

The Product Repair Center is open Monday through Friday 0815 to 1700 Eastern Standard Time or Eastern Daylight Savings Time.

All products returned to the Repair Center are registered upon receipt and a confirmation letter is sent to acknowledge the repair status and the reference number of the product.

We will make every effort to carry out the repair and return your unit as quickly as possible.

If you wish to enquire about the repair status of your unit, contact the Repair Center at:

1-800-539-5539

How can I contact Raymarine in Europe?

You can obtain Technical Support, service and accessories from your authorized Raymarine dealer, or by contacting:

Raymarine Limited
Anchorage Park
Portsmouth, Hants
England PO3 5TD
Tel +44 (0)23 9271 4713
Fax +44 (0)23 9269 4642