

# Scanstrut Scanpod Installation Instructions

## Mast Pod

Parts List		Qty.			Qty.
	M5 x 20mm Pin torx 60523	8**		Half Round Washer	4
	5mm silicone washer 60519	8**		M6x35mm Hex Head Bolt 60635	4
	Mast Pod Back + Seal	1		6mm Nylon Washer 60702	4
	Pod Front	1		Neoprene Washer 60521	4
	Grommet 101817	4		6mm Stainless Steel Washer 60065	4
	Mast Pod Arm	2		M6 Nyloc nut 60060	4
	Cross Brace	2		4.8 x 12mm Rivet 60706	8

Tools Required	
	Power drill
	Hole Saw ø16mm (5/8")
	ø5mm Drill Bit
	2 x 10mm Spanner
	Rivet Gun

Tools Included	
	M5 Pin torx Key Wrench (63516)

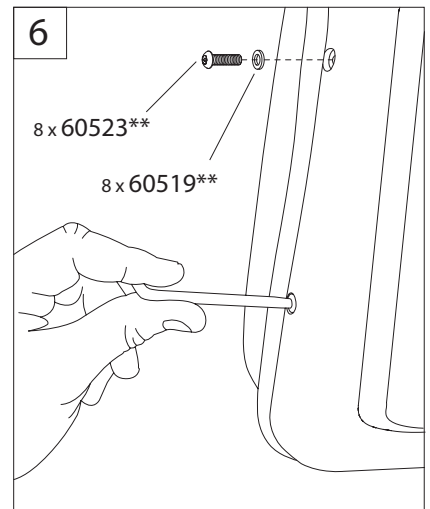
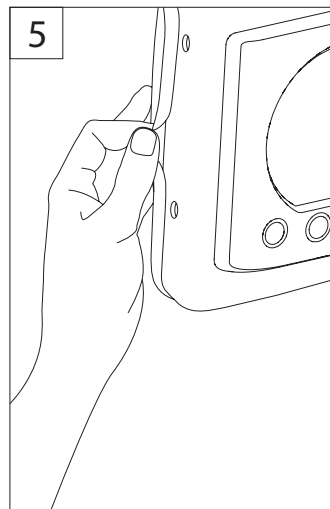
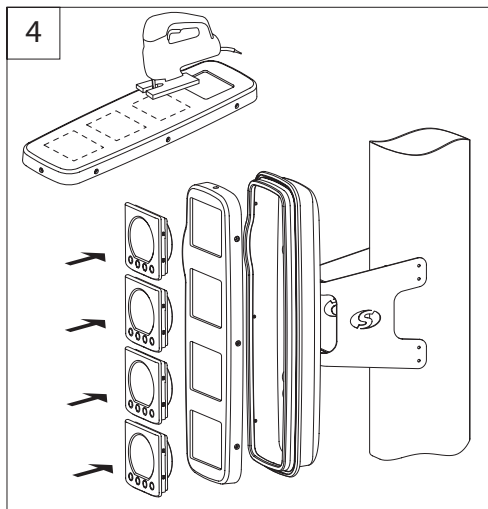
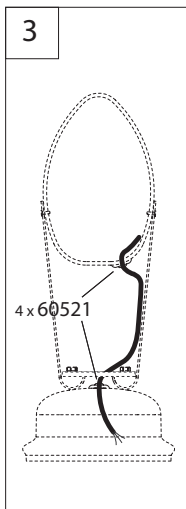
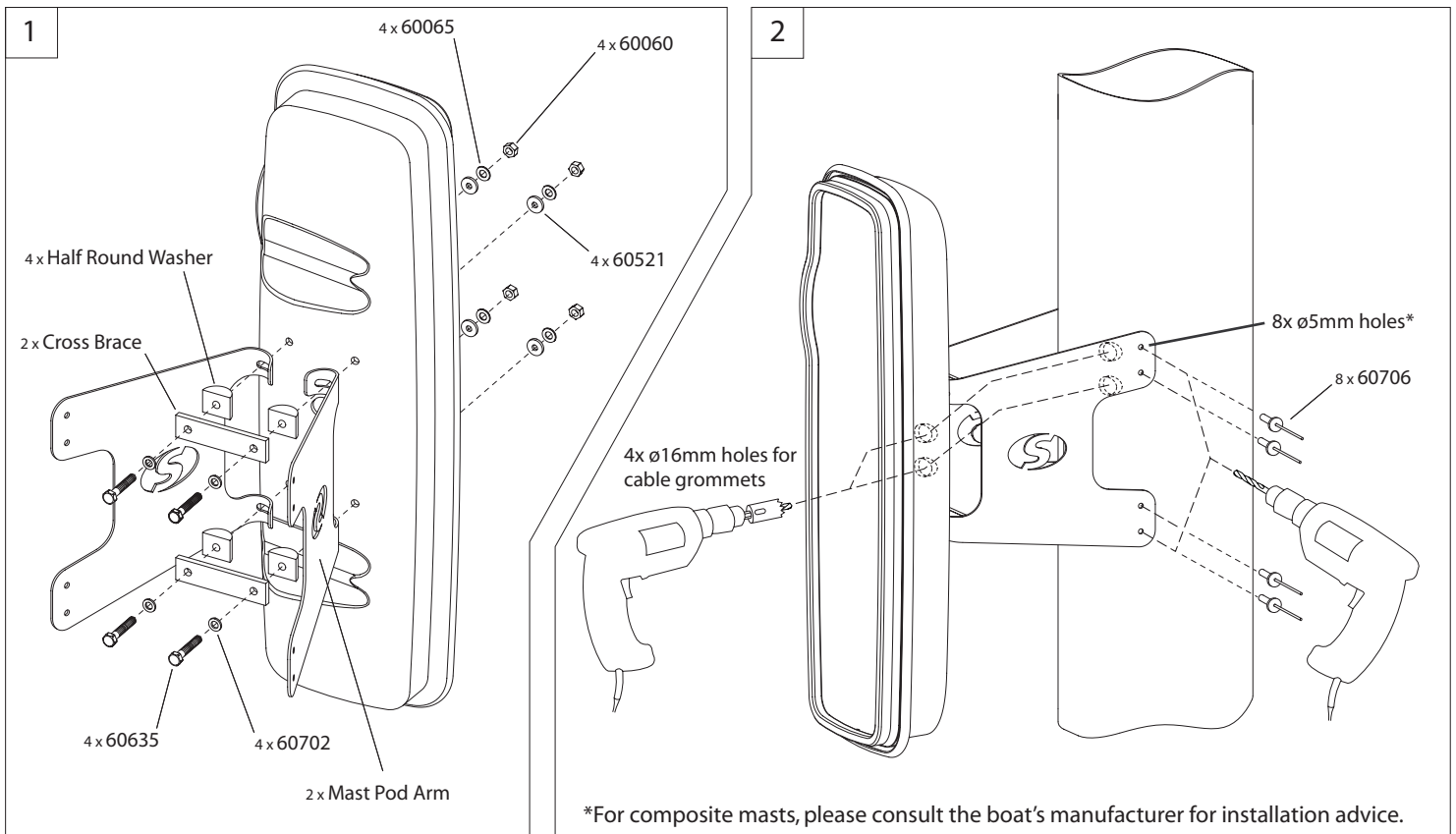

\*\* for SPM-2i, quantity is 6.