

# SILVA Direction

**LOGG • LOG • LOCH**



**Monterings & Bruksanvisning**  
**Installation & Operating description**  
**Installation & Bedienungsanweisung**  
**Description d'installation et d'utilisé**



SILVA SWEDEN AB, Kuskvägen 4, 191 62 Sollentuna

# SILVA 20 DIRECTION DIGITAL LOG

## 1. General description

SILVA 20 is a high quality precision instrument designed to meet the demands from sailors and powerboat owners. The instrument is very easy to read and operate.

**NOTE:** The instrument must be calibrated to your boat. Read the instruction in section 8 carefully and calibrate accordingly.

### LIST OF CONTENTS

1. General
2. Contents list
3. Optional accessories
4. Location of the paddlewheel transducer
5. Installing the through-hull fitting
6. Installing the instrument
7. Operation instruction
8. Calibration
9. Connections
10. Fault finding
11. Data
12. Warranty

## 2. Contents list for the SILVA 20 digital log

The SILVA 20 comes complete with all necessary fittings and attachments for most installations. Included in this box are the following items. Check now to become familiar with each part prior to installation.

- 1 instrument
- 1 gasket
- 1 cable cover plate
- 2x4 stainless screws
- 4 rubber screwcaps
- 1 ribbon plug cable 5 m.
- 1 junction box with connection circuit board
- 1 log transducer
- 1 dummy plug
- 1 silicone grease
- 4 O-rings
- 1 through-hull fitting with nut
- 1 locking device

A two-wire cable from the battery supply is also required.

## 3. Optional accessories

The following items can be supplied as optional extras:

- Option junction box including ribbon cable (part no 9612). This box is necessary for the connection of all optional extras. See further description in section 9.
- External counter for total distance log (part no 2001).
- External audible alarm (part no 8147). An audible alarm is included inside the instrument.
- Cable for connecting SILVA 200-220/2200 as repeater (part no. 9771).
- Bronze through-hull fitting (part no. 9216).
- Remote control (part. no. 9368).

## 4. Correct location of Paddlewheel transducer



The correct positioning of the paddle wheel transducer is of prime importance for the accuracy of the instrument. Generally, the paddlewheel should be located 25-35 % aft along the waterline when the boat is running, as close to the centreline as possible.



Sailboats with a fin keel must have the transducer located at least 10" but not more than 30" in front of the keel. It should be placed no more than 4" off the centreline.



On sailboats with a pronounced 'V' in the hull, such as full-keel yachts, it might be favourable to angle the transducer slightly so that it aims at the bow, rather than directly parallel to the centreline. This will help balance the passing water flow measurement from one tack to another.



Avoid placing the transducer near the edge of sharp hull chines. Transverse water flow in these areas can affect the accuracy of measurements.

If you have questions about the location of the through-hull, contact your builder, yacht dealer, or other Silva owners with similar boats for advice. Always remember to account for accessibility from the inside of the yacht when determining the final location!

### 5. Installation of the through-hull fitting

1. Use a 43mm (1 11/16") hole cutter to cut through the hull. (See section 4 for correct location).
2. Slide both rubber O-rings onto the dummy plug.
3. Generously apply the silicone grease to the exterior of the dummy plug.
4. Install the dummy plug in the through hull fitting. Use a slow twisting motion and be sure the plug is properly seated into the fitting.
5. With the dummy plug properly installed in the through-hull fitting, mount the fitting so that the handle is exactly perpendicular ( 90 degrees) to the boats centre line. (For pronounced V- hulls see section 4).
6. Apply polyurethane sealing compound on the outer flange of the through-hull fitting and tighten the nut on the inside by hand.
7. When this outer sealant has cured, remove the nut and apply sealant on the inside. Tighten the nut again by hand.

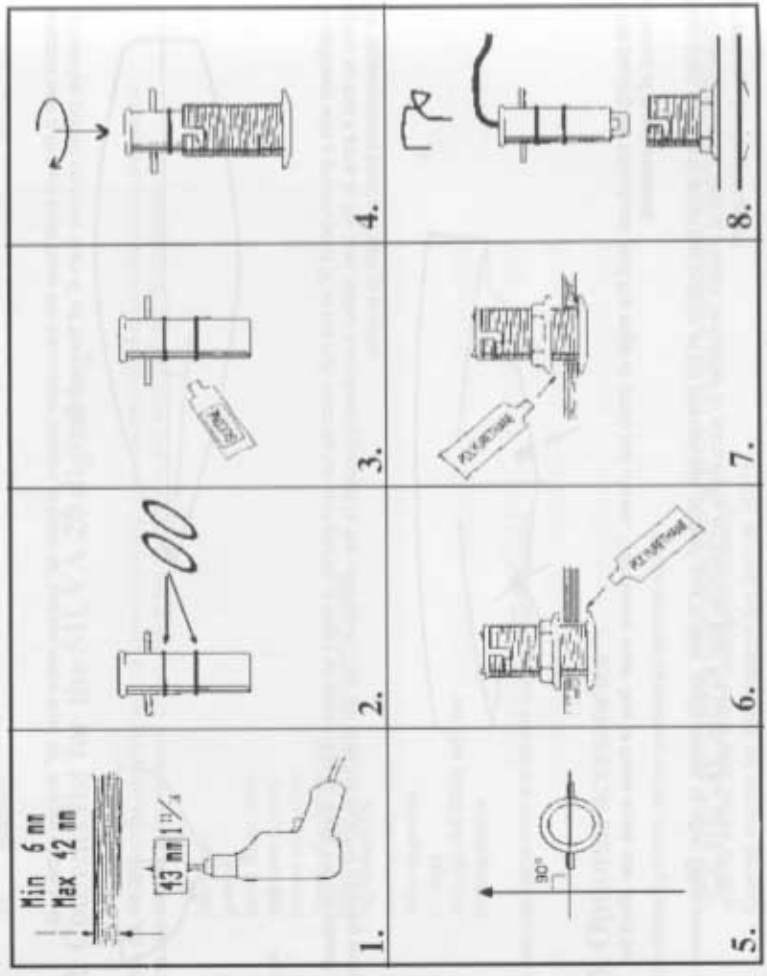

### 6. Installing the instrument

1. Locate the position of the instrument using the template supplied with this handbook. Drill the holes as indicated one in each corner and one for the instrument cable to pass through the bulkhead.
2. Pass the instrument cable through the bulkhead and gasket and connect it to the instrument as illustrated. Mount the cable cover.
3. Use the 4 larger screws supplied to attach the instrument and gasket onto the bulkhead. Alternatively machine type screws and nuts can be used if it is preferred to screw the instrument from the inside (Anti- theft reason). Cover the screws with the screwcaps.
4. Locate the junction box and fasten it with the 4 smaller screws supplied.
5. Attach the cables to the junction box. Pull the cables through the cover plate's opening, plug in the wires, insert the circuit board up-side-down in the slot and snap on the cover plate.
6. When several SILVA Direction units are installed, marking of the junctionboxes and cables is recommended. Labels are enclosed.

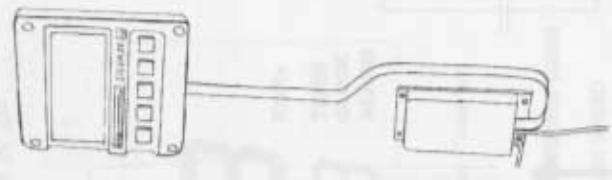

Secure the cables properly near the connection box entry.

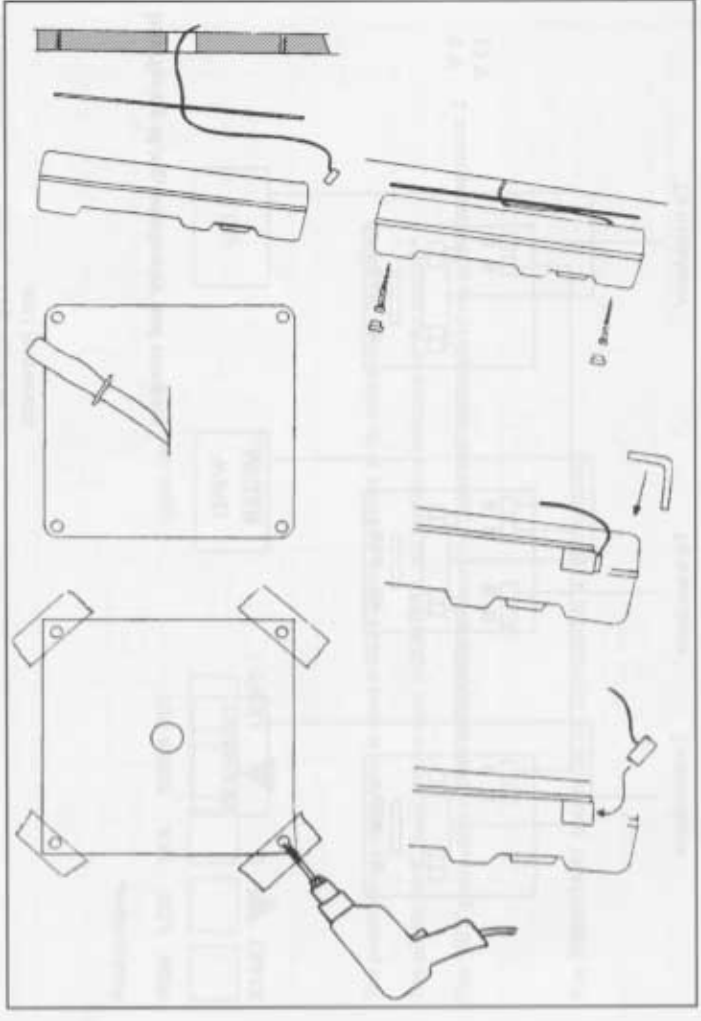

## 7. Operation instruction for the SILVA 20

### 7.1 Functional description

Display

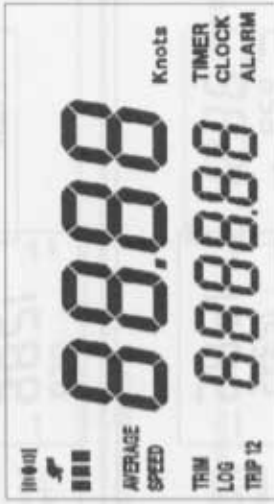

The display's upper part **always** indicates boatspeed. The lower part indicates functions as selected by the pushbuttons. These are:

TRIM	TRIPLOG 1	DAMPING	STARTER COUNTDOWN TIMER
TRIPLOG 2	TOTAL LOG	TIMER AVERAGE SPEED	CLOCK
		CLOCK ALARM	

Pushbuttons.



The pushbuttons' upper case is used to **SELECT** the functions to be indicated on the display.

The pushbuttons' lower case is used to **CONTROL** the functions indicated on the display.

The **'SET'** pushbutton is used to **CHANGE** between the upper and lower case of the pushbuttons.

The **TRIM START** button can be connected to a remote control.

Connection of circuitboard

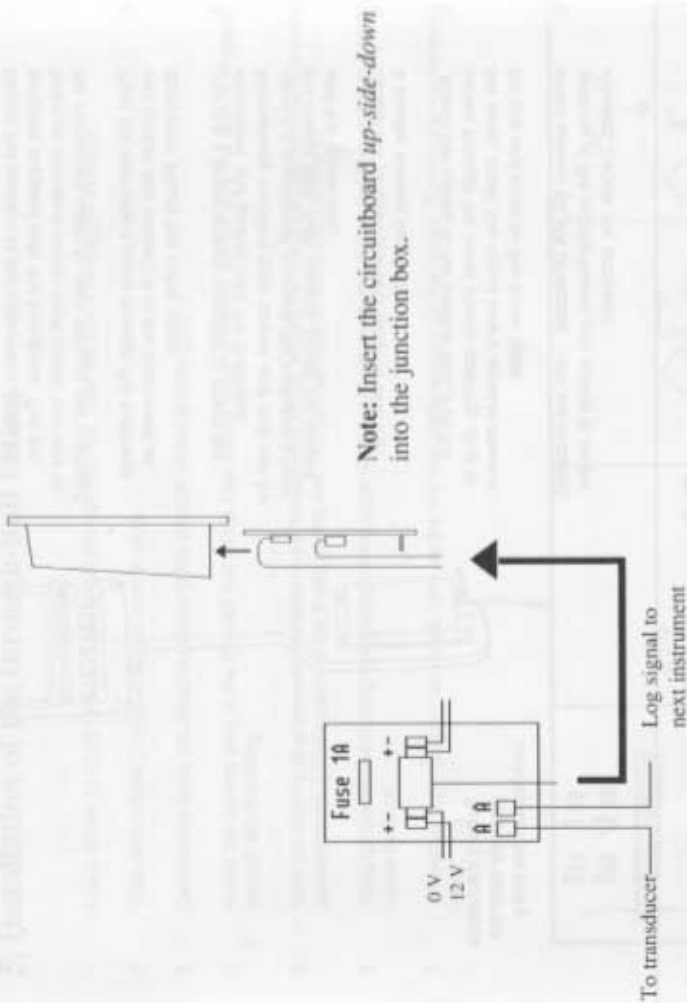

**Note:** Insert the circuitboard *up-side-down* into the junction box.

Interfacing of log, windmeter and compass

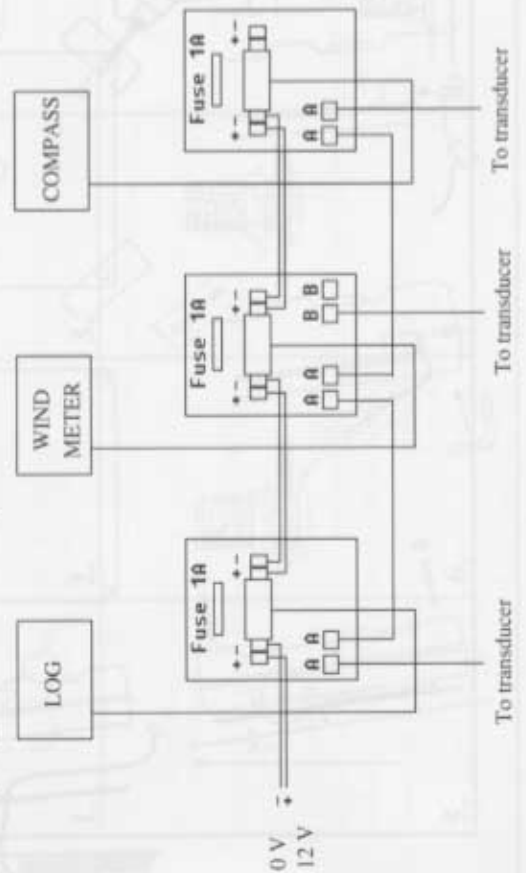

## 7.2 Operation

### TRIM

Press **TRIM**



Increase or decrease of boatspeed is indicated.

### TRIPLOG 1

Press **LOG** until TRIP1 appears

reset

Press **SET C SET**



Triplog 1 indicated in hundredths of a nautical mile.

Triplog 1 is reset. Triplog 1 is also reset when the power is shut off and when the starter timer reaches zero.

preset

Press **SET**



To get an audible alarm after a certain distance, set the triplog to a negative value.

### TRIPLOG 2

Press **LOG** until TRIP2 appears

reset

Press **SET C SET**



Triplog 2 indicates in hundredths of a nautical mile.

Triplog 2 is reset. (Triplog 2 is not reset when the power is shut off.)

preset

Press **SET**

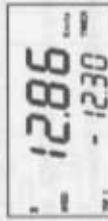

To get an audible alarm after a certain distance, set the triplog to a negative value.

### TOTAL LOG

Press **LOG** until LOG appears



Total distance is indicated in tenths of a nautical mile.

The total log is not resettable.

### SEA ( damping )

Press **SEA**



The damping is indicated by dots in front on the display

- low damping
- medium damping
- high damping

### STARTER ( countdown timer )

Press **SET**

Press **START** and release at shot

To check preset countdown value.

Press **TRIM SET**

For selection of countdown value, see section 7.3.



Countdown starts. Beeps are given 10 seconds prior to start.

During countdown the instrument can be entered into any other mode without interrupting the countdown. You may check the countdown at any time by pressing "TIMER".

If you want to change the countdown value in progress do as follows

Select **TIMER**

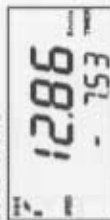

Countdown value appears.

Press **SET**



New countdown value indicated.

Press **SET** and release at shot



New countdown starts.

### TIMER

Press **TIMER** until TIMER is shown

reset

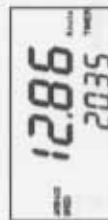

Average speed displayed for 4 sec on the upper display. Elapsed time from start indicated.

Press **SET C SET**



The timer is reset. This happens also when the starter reaches zero.

preset

Press **SET**



If preset to a negative value, the timer counts down to zero and gives audible alarm.

### 7.3 Start up procedure

Your instrument must be set up with certain values to operate with the best possible accuracy. The following routine need only be done once. Once inserted the values are stored permanently even when the power is shut off.

Do as follows:

press **TRIM** and **SET** simultaneously until the display indicates a code on the upper display. The lower display indicates the value to be altered. See below.

- **C0: calibration value** ( see section 8 )

to alter press **◀** **SET** new calibration value indicated **▶**

If the value should not be altered, only press "SET" to step to the next code.

- **C1: selection of countdown value for the starter timer.**

to alter press **◀** **SET** new start value indicated **▶**

- **C2: selection of pulse rate on the log's output**

to alter press **C** until 00 or 01 appear, **SET**  
press **SET**  
00 = 10 pulses per nautical mile  
01 = 100 pulses per nautical mile

The start up values are now stored permanently and the instrument reverts automatically to normal operation.

#### CLOCK

Press **TRIM** until **CLOCK** is shown

Actual time is indicated in hours and minutes.

12.86  
2359

set

Press **SET** **◀** **SET** **▶**

New time indicated.

12.86  
0105

#### ALARM

Press **TRIM** until **ALARM** is shown

Alarm time.

12.86  
1625

set

Press **SET** **◀** **SET** **▶**

New alarm time indicated.

12.86  
0830

#### disengage

Press **SET** **C** **SET**

Alarm disengaged.

12.86  
0830

#### AVERAGE SPEED

Press **TRIM** until **TIMER** is shown

Average speed indicated for 4 seconds on the upper display. Timer indicated continuously.

12.86  
2035

Average speed and timer are reset when power is shut off and when start timer reaches zero.

#### LIGHT

Press **LIGHT** and hold until light goes on/off

Instrument light is switched from OFF to medium to strong light and back to OFF when pushbutton is pressed.

12.86  
12345

Instrument consumes only 5mA when light is OFF.

## 8. Calibration of the SILVA 20

To ensure the accuracy of your SILVA log it is essential to calibrate its readings. The waterflow varies greatly from one design to the other and therefore this must be taken into account on your boat too!

The **SILVA 20** can be calibrated to within 1% accuracy quite easily by travelling a known distance and comparing it to the reading of your log.

### How to determine the calibration value for your boat:

Use the following formula for determining the correct calibration value:

$$\frac{\text{real distance (from a chart)}}{\text{measured distance (what your log says)}} = \text{calibration value}$$

For example: You zeroset your log and travel a known distance of 2.3 nautical miles but your log says you have travelled only 1.8 nautical miles. The calibration factor is calculated:

$$\frac{2.3}{1.8} = 1.28$$

28 is the calibration value in this example.

The calibration value should be entered as described in section 7.3

## 9. Electrical connections / circuit diagrams

When installed according to section 6 the instrument operates without any further precautions. If optional extras are required an **option junction box** is necessary ( part no. 9612 ).

The connection is shown below.

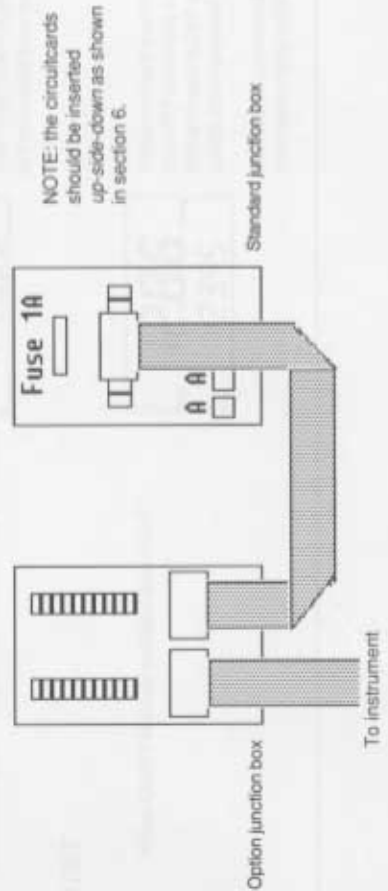

### 9.1 Connection of additional Direction logs as repeaters

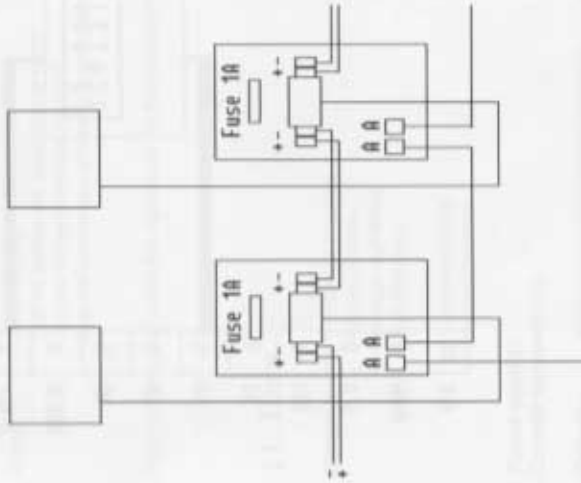

### 9.2 Remote control

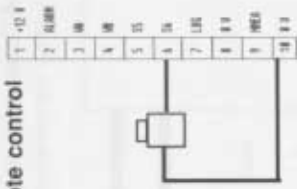

### 9.3 Connection of other Silva logs as repeaters

**A:** If an A-plug in your junctionbox is free, connect to this plug (cable no. 9771.)

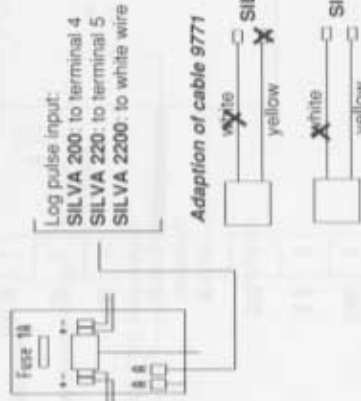

**B:** If no A-plug is available, connect to option junction box (cable no. 9771).

Log pulse input:  
SILVA 200: to terminal 4  
SILVA 220: to terminal 5  
SILVA 2200: to white wire

Adaption of cable 9771



9 NIEA  
10 0 U

## 10. Fault finding

Most faults on electronic equipment can be found in the outer wiring and this should always be checked first if a fault arises.

**Check:** power supply that no cables are squashed or worn that the screw terminals are tight that the connection is made properly as per the wiring diagram

If no fault is found check the transducer for free paddlewheel rotation and possible damage to cable.

## 11. Data

**Dimensions:** 125 x 125 x 30 mm  
140 x 68 x 42 mm  
dia 42 x 86 mm  
min 6 mm  
max 42 mm  
5m  
8m

instrument housing connection box through-hull fitting hull thickness instrument cable transducer cable

**Power supply:** 12V DC (10-18V)  
**Current consumption:** 5mA (45mA with illumination)

**Outputs:** External counter/satellite navigator  
External alarm  
Log pulse

open collector transistor  
10 or 100 pulses per nautical mile  
open collector transistor  
0-5V sink 30mA max

**Measuring ranges:** 0.2-50 knots, Tot. -99999.9 nM, Trip -9999.9 nM.  
**Accuracy:** +1% after calibration excluding errors due to transducer location.

**Calibration:** 100% in steps of 1%.

**Temperature range:** -35C to + 85C  
Operation  
-10C to + 70C

**NMEA 0183 data output:** 8 data bits (D7=0), no parity, 2 stopbits  
1/ second  
0 - 10 V DC, sink/source 25 mA.

message: \$XXVHW,....00.00.N.,  
normally: speed  
when starter timer is running: 9.59 (or lower)

## 12. Warranty

SILVA gives a two year warranty against manufacturing faults or faulty components. A purchasing receipt must be shown if a warranty claim is made.

### 9.5 Connection of external counter

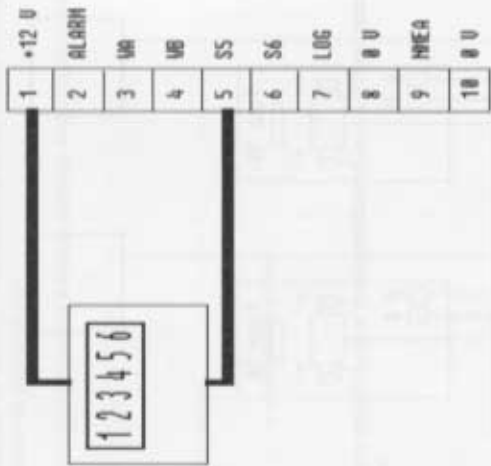

### 9.4 Connection of audible alarm

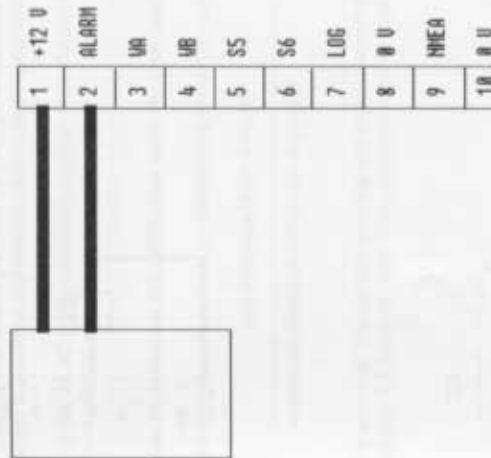

### 9.7 Connection of satellite navigator

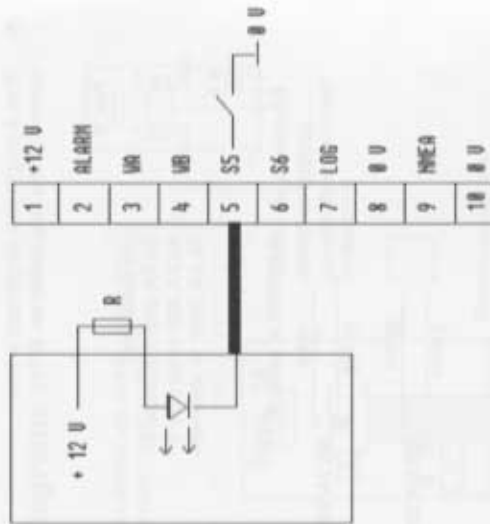

### 9.6 Connection of NMEA dataline

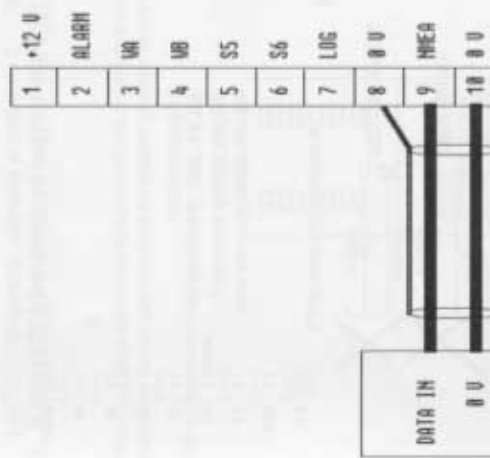



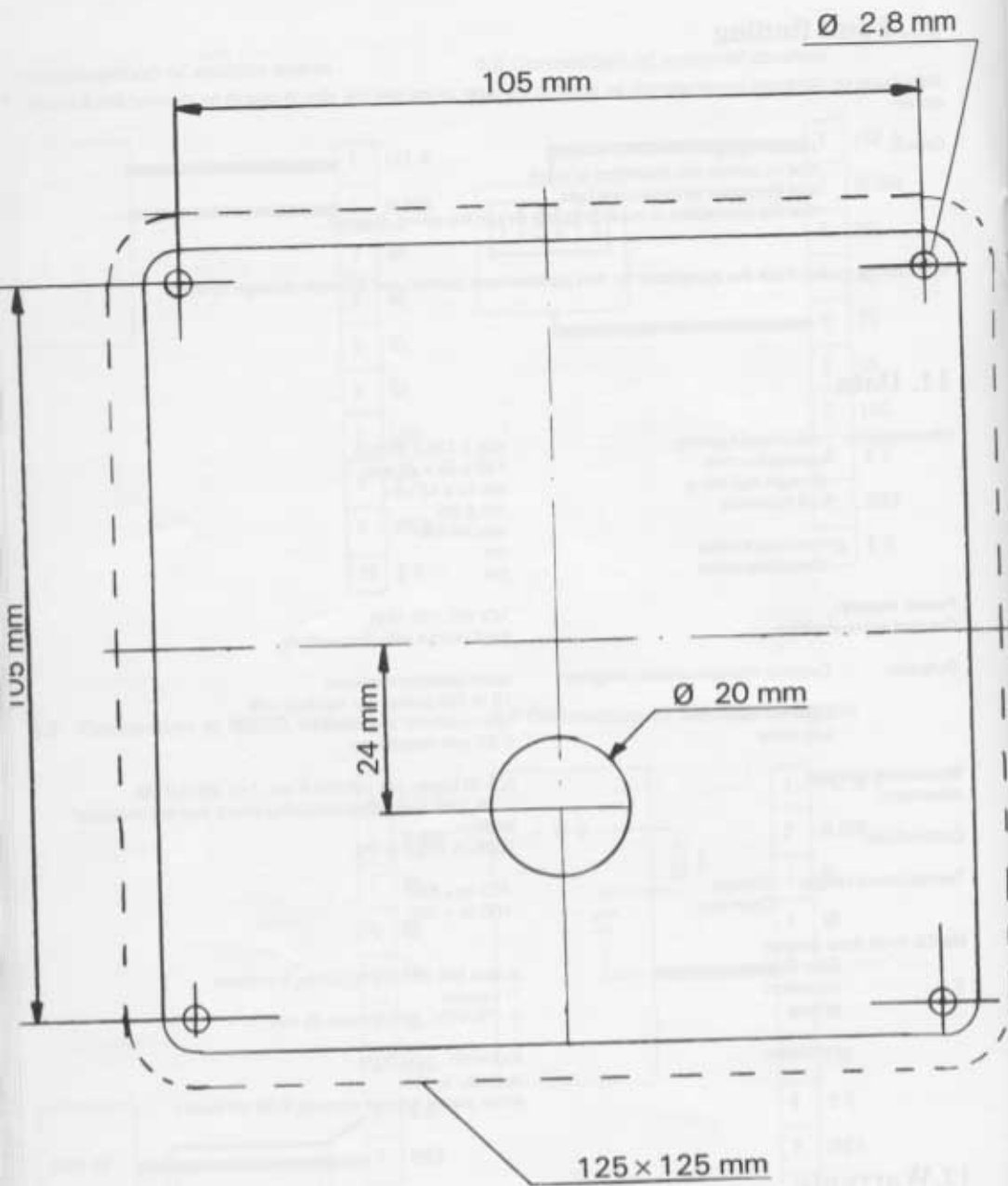

Printed in Sweden