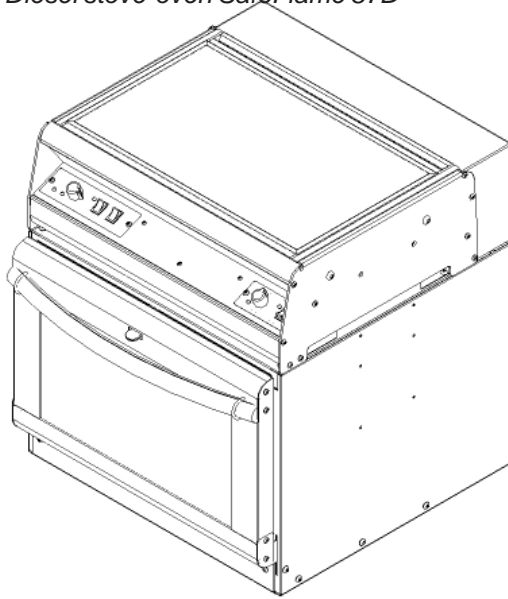

Figure 1: Diesel stove-oven SafeFlame 87D



Content of the package

- 1 pc 87D diesel stove-oven
- 1 pc Baking sheet
- 1 pc Baking tray
- 1 pc Auxiliary bag
- 2 x 4 m Power cord
- 4 m Fuel hose with a filter
- 2 pcs Mounting pieces (front and rear)
- 2 pcs Lifting handle of stove-oven

Content of the auxiliary bag:

- 4 pcs 5 x 16 standard screw
- 1 pc Hose clamp
- 1 pc Fuse box bag

Operation

SafeFlame 87D is a safe diesel stove-oven with no open flame. The stove-oven consists of the combination

of diesel oven SafeFlame 86D and diesel stove SafeFlame 85DP. The technical details, instructions and servicing

recommendations given for 85DP apply to the stove element, and instructions for 86D apply to the oven element.

Cut-out for the installation

The minimum cut-out for the oven is 500 x 530 x 540 mm (figure 2). The bottom of the cut-out shall have openings for cooling air with a minimum area of 100 cm².

The cut-out shall be made of fireproof material or lined with fireproof material. The stove-oven is attached to the cut-out in the same way as oven 86D.

The installation cut-out of the stove-oven must have a replacement air opening of at least 100 cm².

Figure 2: Cut-out for installation of 87D.

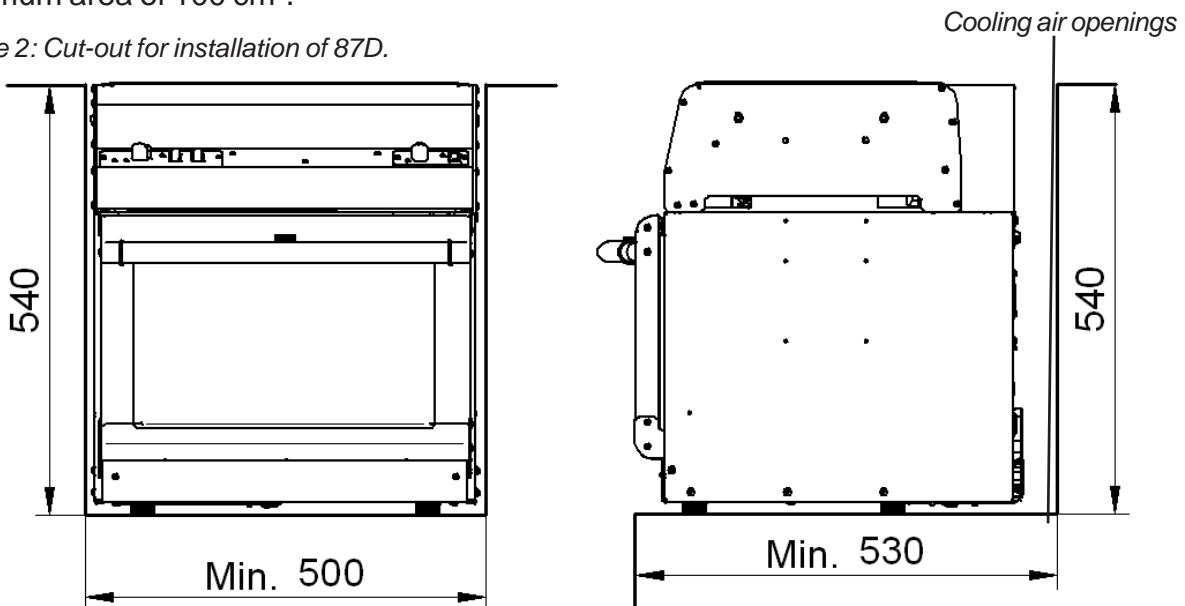

Connections

The connections of the stove-oven are similar to those of a separate oven and stove with a few exceptions. The stove-oven has a T-branch for the fuel hose. The common fuel feed of the oven and stove is connected to the branch facing down.

The exhaust pipe of the stove is at the back edge of the stove to ease installation.

Solenoid valve for the stove-oven:

If a solenoid valve is installed to the fuel system, it must open when the stove or oven is used. A relay card to whose connector C2 the wires of the solenoid valve are attached (figure 4) is available as an accessory to 87D. More detailed instructions on connecting the solenoid valve are delivered with the relay card.

Figure 3: Connections of 87D that deviate from those of a separate oven and stove.

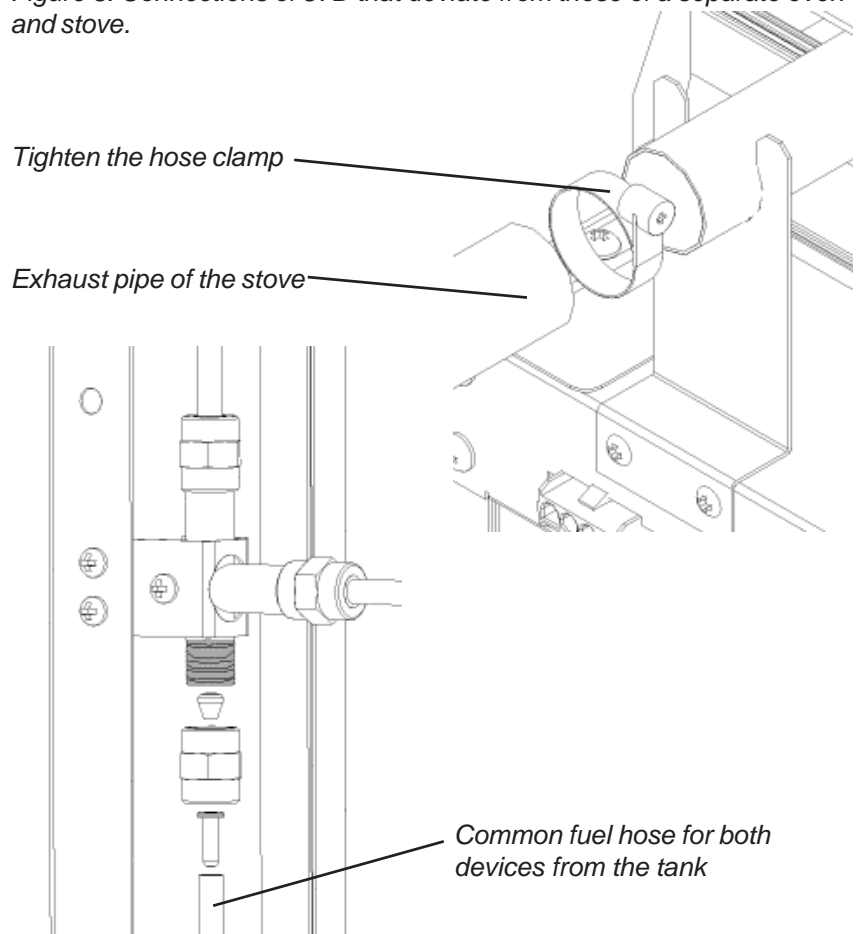
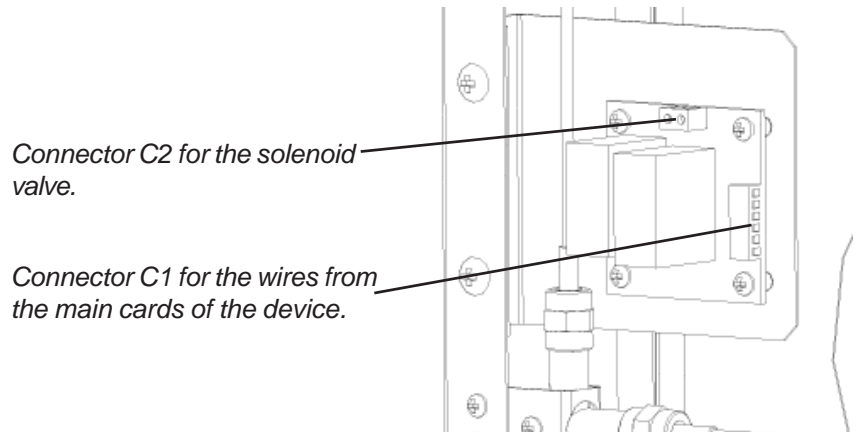

Figure 4: Fastening the relay card and solenoid valve to the stove-oven.



Use of the stove-oven

The stove and oven are used in the same way as 85DP and 86D.

Simultaneous starting of the oven and stove is not recommended; the battery voltage might drop too much, because both devices

require 8 A heater current to start. You should wait for approximately 5 minutes before re-starting.