

IP 55

IMO
BSH



12 V
24 V

BAY 15d



10 / 25 W

Navigation lights aqua signal 41

Application: All vessels < 20 m in length. Lights marked with index ⚓ may also be used on inland waterways without limitation of ship's length. Applicable on national waterways up to the border of the high seas

Approvals: International according to IMO 1972, in Germany through BSH, other countries in particular see list of approvals

Min. visibilities: 2 n.m., masthead light 3 n.m.

Protection class: IP 55

Housing: Rigid polycarbonate. Nonmagnetic, seawater resistant

Housing colour: Mat black or white

Optics: Easy to change, rigid acrylic Fresnel lens

Electric: Plug connection 2 x 6.3 mm (automotive)

Cable insert: From rear (off center, left or right) through protective silicone rubber grommet

Lamp (included): Easy to change, special vertical filament tungsten bulb with socket BAY 15d

Mounting: Direct to bulkhead by means of 2 screws Ø 4 mm. Further mounting aids see drawing

Navigationslaternen aqua signal 41

Einsatzbereich: Wasserfahrzeuge < 20 m Länge.

Alle in der Tabelle mit ⚓ gekennzeichneten Laternen dürfen auf europäischen Binnenschiffen gefahren werden. Die Längenbegrenzung ist dann aufgehoben. Zur Verwendung auf Seeschiffahrtsstraßen bis zur Grenze der Seefahrt

Zulassung: International entsprechend IMO 1972. In Deutschland durch das BSH, andere Länder siehe Zulassungstabelle

Mindesttragweite: 2 sm, Topplaterne 3 sm

Schutzklasse Navigationslaternen: IP 55

Gehäuse: Bruch- und verformungsstabiles Polycarbonat. Amagnetisch, seewasserfest

Gehäusefarbe: Mattschwarz oder weiß

Optik: Leicht auswechselbare schlag- und stoßfeste Acrylglas - Fresnellinse

Elektrik: Anschluß mit 2 Flachsteckhülsen 6,3 mm

Kabeleinführung: Durch die Rückwand von rechts



oder links

Leuchtmittel (gehört zum Lieferumfang): Leicht auswechselbare Spezialglühlampe mit Sockel BAY 15d

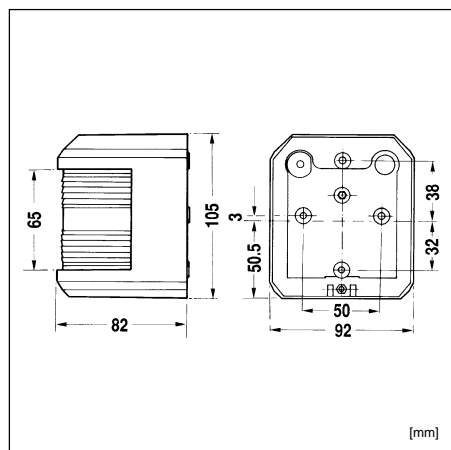
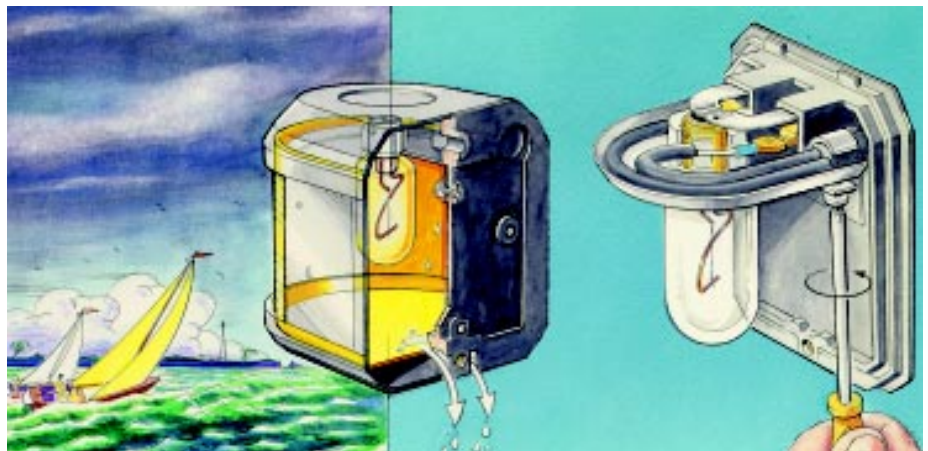
Montage: Hautnahe Montage mit 2 Schrauben Ø 4 mm. Anbaubehör siehe Zeichnung



| Type / Typ | Part No. / Bestell-Nr. | Black housing Gehäuse schwarz | | White housing Gehäuse weiß | | kg |
|---------------------------------------|-------------------------------------|----------------------------------|---------|-------------------------------|---------|------|
| | | 12 V | 24 V | 12 V | 24 V | |
| 1 x 25 W | Starboard / Steuerbord | ⚓ 3543102 | 3543103 | 3543623 | 3543626 | 0,27 |
| | Port / Backbord | ⚓ 3544202 | 3544203 | 3544623 | 3544626 | |
| | Bicolor side / doppelfarbige Seiten | ⚓ 3542302 | 3542303 | 3542623 | 3542626 | |
| | Masthead / Topp | ⚓ 3540002 | 3540003 | 3540623 | 3540627 | |
| 1 x 10 W | Stern / Heck | ⚓ 3541002 | 3541003 | 3541623 | 3541626 | |
| | Stern yellow / Heck gelb | 3541402 | 3541403 | - | - | |
| Combined *Masthead - Foredeck - light | 50 W *⚓ | 3108002 | 3108003 | 3108012 | 3108013 | 0,20 |
| Komb. *Topplaterne - Deckstrahler | 35 W *⚓ | 3108004 | - | 3108014 | - | |

| | | | |
|--|------|---|--|
| IP 67 | 12 V | Halogen  12 V / 50 W | PAR 36  12 V / 35 W |
| | 24 V | | |
| PAR 36  24 V / 50 W | | | |



aqua signal 41 Combined Masthead / Foredeck - Light

Protection class: IP 67 (watertight)
Housing: Polycarbonate, supporting unit, polyamid, seawater resistant, rigid, nonmagnetic, UV - resistant
Housing colour: Mat black or white
Electric: A 3-core cable is sufficient for supply
Lamp (included): Built - in easy to change sealed beam, 12 V / 50 W halogen or 12 V / 35 W, 24 V / 50 W PAR 36
Mounting: Easy to fit to each mast profile by means of flexible flaps

Technical data masthead light: page 28

12 V / 50 W Halogen oder 12 V / 35 W, 24 V / 50 W PAR 36

Montage: Einfache Montage an jedem Mastprofil durch flexible Befestigungslaschen

Technische Daten der Topplaterne: Seite 28

aqua signal 41 Kombination Topplaterne / Deckstrahler

Schutzklasse: IP 67 (wasserdicht)
Gehäuse: Polycarbonat, Halterung, Polyamid amagnetisch, seewasserbeständig, UV - beständig, bruch- und verformungsstabil
Gehäusefarbe: Mattschwarz oder weiß
Elektrik: Zur Versorgung ist ein 3 - adriges Kabel ausreichend
Leuchtmittel (im Lieferumfang enthalten): Eingebauter leicht auswechselbarer Lichteinsatz,

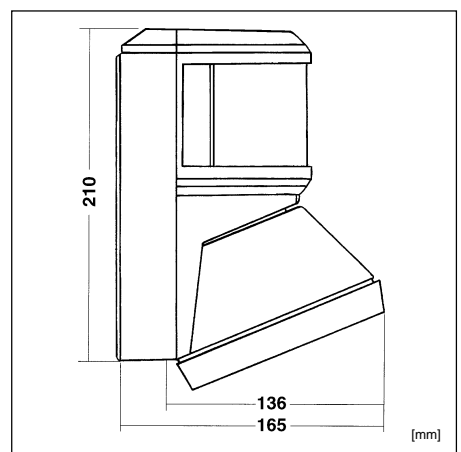

Spare Parts / *Extras – Ersatzteile / *Zubehör

Spare Parts for Foredeck - Light: page 50 / Ersatzteile Deckstrahler: Seite 50

- white/weiß 23540002
- red-green/rot-grün 23542002
- red/rot 23544002
- green/grün 23543002
- yellow/gelb 23541004
- Starboard/Steuerbord
black/schwarz 23543001
white/weiß 23543006
- Port/Backbord
black/schwarz 23544001
white/weiß 23544006
- Masthead + Bicolour/
Topp + Doppelfarbig
black/schwarz 23540001
white/weiß 23540015
- Stern/Heck
black/schwarz 23541001
white/weiß 23541008
- 23540005
- 12V/25W 90400002
- 24V/25W 90400003
- 12V/10W 90400005
- 24V/10W 90400006
- Complete/Komplett 83540001

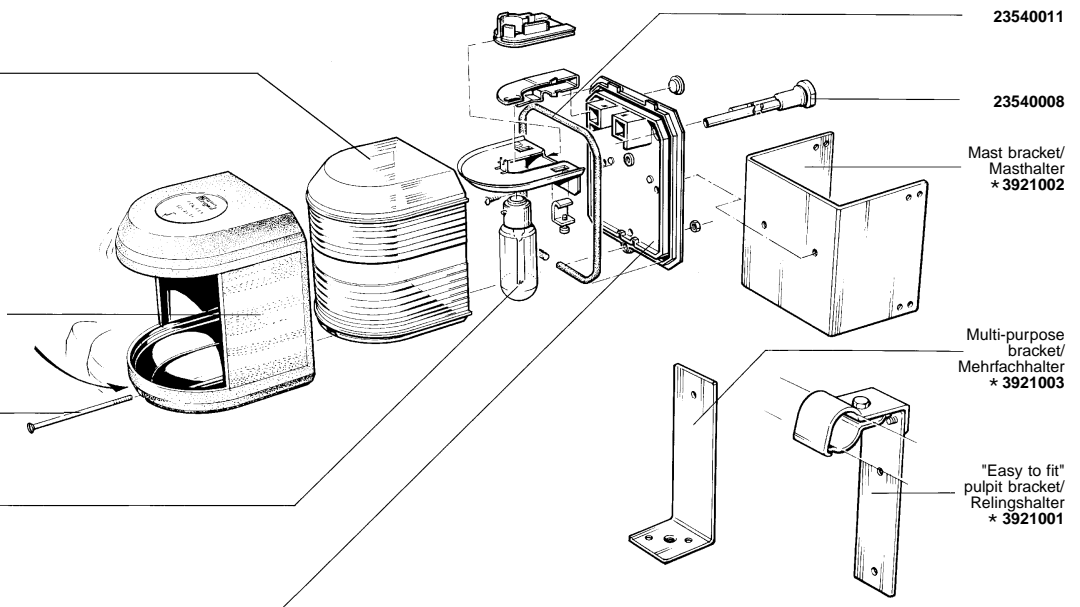

* Extras not included / *Zubehör gehört nicht zum Lieferumfang

List of approvals for aqua signal navigation lights / Zulassungsliste für aqua signal Navigationslaternen

| Country: | Länder: | GB | CDN | D | AUS | NL | F | SF | N | DK | S | IS | PL |
|--|-----------------------|---------|-----|-----|------|-------|--------|-----|-----|-----|-----|----|-----|
| Authority: | zugelassen durch: | DOT/MSA | DOT | BSH | AMSA | DGSM | MM/CCS | MKH | NMD | DMA | NMA | SR | PRS |
| aqua signal 20 | | | | | | | | | | | | | |
| Masthead | Topp | 7* | 7 | | 7* | 8 | 8 | | | | | | 7* |
| Side lights | Seiten | 7* | 7 | | 7* | 8 | 8 | | | | | | 7* |
| Side lights/top mount | Seiten/Anbau | – | 7 | | – | 8 | 8 | | | | | | 7* |
| Bicolour | doppelfb. Seiten | 7* | 7 | | 7* | 8 | 8 | | | | | | 7* |
| Stern | Heck | 7* | 7 | | 7* | 8 | 8 | | | | | | 7* |
| Allround white | Signal weiß | 7* | 7 | | 7* | 8 | 8 | | | | | | 7* |
| aqua signal 25 | | | | | | | | | | | | | |
| Masthead | Topp | 2* | 2* | | 2* | 8 | 2* | 2* | 1* | 2* | 2* | 1* | 2* |
| Side lights | Seiten | 2* | 2* | | 2* | 8 | 2* | 2* | 1* | 2* | 2* | 1* | 2* |
| Bicolour | doppelfb.Seiten | 2* | 2* | | 2* | 8 | 2* | 2* | 1* | 2* | 2* | – | 2* |
| Stern | Heck | 2* | 2* | | 2* | 8 | 2* | 2* | 1* | 2* | 2* | 1* | 2* |
| Allround white | Signal weiß | 2* | 2* | | 2* | 8 | 2* | 2* | 1* | 2* | 2* | 1* | 2* |
| Comb.Masth./Deck | Topp/Deckstrahler | 2* | 2* | | 2* | 8 | 2* | 2* | – | 2* | 2* | – | 2* |
| aqua signal 40 | | | | | | | | | | | | | |
| Masthead | Topp | 3* | 3* | 3* | 3* | 3**** | 3* | 3* | 2* | 3* | 3* | 2* | 3* |
| Side lights | Seiten | 3* | 3* | 3* | 3* | 3**** | 3* | 3* | 2* | 3* | 3* | 2* | 3* |
| Bicolour | doppelfb.Seiten | 3* | 3* | 3* | 3* | 3**** | 3* | 3* | 2* | 3* | 3* | 2* | 3* |
| Stern | Heck | 3* | 3* | 3* | 3* | 3**** | 3* | 3* | 2* | 3* | 3* | 2* | 3* |
| Stern yellow | Heck gelb | – | – | 3* | – | 3**** | – | 3* | – | – | 3* | – | – |
| Tricolour | dreifb. Segler | 3* | 3* | 3* | 3* | 3**** | 3* | 3* | 2* | 3* | 3* | – | 3* |
| Tricolour/Anchor | dreifb. Segler/Signal | 3* | 3* | 3* | 3* | 2**** | 3* | 3* | 2* | 3* | 3* | – | – |
| Allround lights | Signal | 3* | 3* | 3* | 3* | 3**** | 3* | 3* | 2* | 3* | 3* | – | 3* |
| Masth./Signal white | Topp/Signal weiß | 3* | 9 | 3* | 9 | 3**** | 9 | 3* | 9 | 3* | 3* | – | – |
| aqua signal 41 | | | | | | | | | | | | | |
| Masthead | Topp | 3* | 3* | 3* | 3* | 3**** | 3* | 3* | 2* | 3* | 3* | 3* | 3* |
| Side lights | Seiten | 3* | 3* | 3* | 3* | 3**** | 3* | 3* | 2* | 3* | 3* | 3* | 3* |
| Stern | Heck | 3* | 3* | 3* | 3* | 3**** | 3* | 3* | 2* | 3* | 3* | 3* | 3* |
| Bicolour | doppelfb. Seiten | 3* | 3* | 3* | 3* | 3**** | 3* | 3* | 2* | 3* | 3* | 3* | 3* |
| aqua signal 42 | | | | | | | | | | | | | |
| Side lights | Seiten | 3* | 9 | 3* | 9 | 3**** | 3* | 3* | 9 | 3* | 3* | – | – |
| Stern | Heck | 3* | 9 | 3* | 9 | 3**** | 3* | 3* | 9 | 3* | 3* | – | – |
| aqua signal 50 | | | | | | | | | | | | | |
| Masthead | Topp | 3* | 3* | 3* | 3* | 3**** | 3* | 3* | 3* | 3* | 3* | 3* | 3* |
| Masth. 5nm (TW 50) | Topp 5 sm (TW 50) | 4* | 4* | – | 4* | – | – | 4* | – | – | – | – | – |
| Side lights | Seiten | 3* | 3* | 3* | 3* | 3**** | 3* | 3* | 3* | 3* | 3* | 3* | 3* |
| Stern | Heck | 3* | 3* | 3* | 3* | 3**** | 3* | 3* | 3* | 3* | 3* | 3* | 3* |
| Allround | Signal | 3* | 3* | 3* | 3* | 3**** | 3* | 3* | 3* | 3* | 3* | 3* | 3* |
| aqua signal 55 | | | | | | | | | | | | | |
| Masthead | Topp | 5* | 5* | 5* | 5* | 5* | 5* | 5* | 5* | 5* | 5* | 5* | 5* |
| Side lights | Seiten | 5* | 5* | 5* | 5* | 5* | 5* | 5* | 5* | 5* | 5* | 5* | 5* |
| Stern | Heck | 5* | 5* | 5* | 5* | 5* | 5* | 5* | 5* | 5* | 5* | 5* | 5* |
| Stern yellow | Heck gelb | 5* | 5* | 5* | 5* | 5* | 5* | 5* | 5* | 5* | 5* | 5* | 5* |
| Allround | Signal | 5* | 5* | 5* | 5* | 5* | 5* | 5* | 5* | 5* | 5* | 5* | 5* |
| aqua signal 70 (single optic / einlinsig) | | | | | | | | | | | | | |
| Masthead | Topp | 6* | 6* | 6* | 6* | 6* | 6* | 6* | 6* | 6* | 6* | 6* | 6* |
| Side lights | Seiten | 6* | 6* | 6* | 6* | 6* | 6* | 6* | 6* | 6* | 6* | 6* | 6* |
| Stern | Heck | 6* | 6* | 6* | 6* | 6* | 6* | 6* | 6* | 6* | 6* | 6* | 6* |
| Stern yellow | Heck gelb | 6* | 6* | 6* | 6* | 6* | 6* | 6* | 6* | 6* | 6* | 6* | 6* |
| Allround | Signal | 6* | 6* | 6* | 6* | 6* | 6* | 6* | 6* | 6* | 6* | 6* | 6* |
| Manoeuvring light | Manöver | 6* | 9 | 6* | 9 | 6* | 9 | 9 | 6* | 6* | 6* | 9 | 6* |
| aqua signal 70 M / 70 D (double optic / doppellinsig) | | | | | | | | | | | | | |
| Masthead | Topp | 6* | 6* | 6* | 6* | 6* | 6* | 6* | 6* | 6* | 6* | 6* | 6* |
| Side lights | Seiten | 6* | 6* | 6* | 6* | 6* | 6* | 6* | 6* | 6* | 6* | 6* | 6* |
| Stern | Heck | 6* | 6* | 6* | 6* | 6* | 6* | 6* | 6* | 6* | 6* | 6* | 6* |
| Allround | Signal | 6* | 6* | 6* | 6* | 6* | 6* | 6* | 6* | 6* | 6* | 6* | 6* |
| aqua signal 55 class IV | | | | | | | | | | | | | |
| Sound signalling appliance | Schallsignalanlage | 3* | 3* | 3* | | | | 3* | 3* | 3* | 3* | | |

| I | B | ZA | RUS | USA | GR | NZ | VRC | RC | RA |
|-------|-----|-----|------|---------------|-----|-----|-----|-----|----|
| RINA | BZI | DOT | RS | USCG/BIA MOMB | MSA | CCS | CS | PNA | |
| 7* | 8 | 7* | 8 | 7* | 7* | 7* | 7 | 7 | |
| 7* | 8 | 7* | 8 | 7* | 7* | 7* | 7 | 7 | |
| – | 8 | 7* | 8 | 7* | 7* | 7* | 7 | 7 | |
| 7* | 8 | 7* | 8 | 7* | 7* | 7* | 7 | 7 | |
| 7* | 8 | 7* | 8 | 7* | 7* | 7* | 7 | 7 | |
| 7* | 8 | 7* | 8 | 7* | 7* | 7* | 7 | 7 | |
| 2* | 8 | 8 | 8 | 2* | 2* | 2* | 2 | 2 | 2* |
| 2* | 8 | 8 | 8 | 2* | 2* | 2* | 2 | 2 | 2* |
| 2* | 8 | 8 | 8 | 2* | 2* | 2* | 2 | 2 | 2* |
| 2* | 8 | 8 | 8 | 2* | 2* | 2* | 2 | 2 | 2* |
| 2* | 8 | 8 | 8 | 2* | 2* | 2* | 2 | 2 | 2* |
| 2* | 8 | 8 | 8 | 2* | 2* | 2* | 2 | 2 | 2* |
| 3* | 3* | 8 | 8 | 3* | 3* | 3* | 3 | 3 | 3* |
| 3* | 3* | 8 | 8 | 3* | 3* | 3* | 3 | 3 | 3* |
| 3* | 3* | 8 | 8 | 3* | 3* | 3* | 3 | 3 | 3* |
| 3* | 3* | 8 | 8 | 3* | 3* | 3* | 3 | 3 | 3* |
| 3* | – | 8 | 8 | 3* | – | – | 3 | 3 | 3* |
| 3* | – | 8 | 8 | 3* | 3* | 3* | 3 | 3 | 3* |
| 3* | 3* | 8 | 8 | 3* | 3* | 3* | 3 | 3 | 3* |
| 9 | 3* | 8 | 8 | | 3* | 9 | 3 | 3 | 9 |
| 3**** | 8 | 8 | 8 | 3* | 3* | 3* | 3 | 3 | 3* |
| 3**** | 8 | 8 | 8 | 3* | 3* | 3* | 3 | 3 | 3* |
| 3**** | 8 | 8 | 8 | 3* | 3* | 3* | 3 | 3 | 3* |
| 3**** | 8 | 8 | 8 | 3* | 3* | 3* | 3 | 3 | 3* |
| 9 | 3* | 8 | 8 | | 3* | 9 | 3 | 3 | – |
| 9 | 3* | 8 | 8 | | 3* | 9 | 3 | 3 | – |
| – | 8 | | 3* | | 3* | 3 | 3 | 3* | |
| 4* | 8 | – | 3* | | 4* | 4 | 4 | 4* | |
| – | 8 | – | 3* | | 3* | 3 | 3 | 3* | |
| 3* | 8 | – | 3* | | 3* | 3 | 3 | 3* | |
| 3* | 8 | – | 3* | | 3* | 3 | 3 | 3* | |
| 4** | 5* | 5* | 5*** | 5* | 5* | 5* | 5** | 5 | 5* |
| 4** | 5* | 5* | 5*** | 5* | 5* | 5* | 5** | 5 | 5* |
| 4** | 5* | 5* | 5*** | 5* | 5* | 5* | 5** | 5 | 5* |
| 4** | 5* | 5* | 5*** | 5* | 5* | 5* | 5** | 5 | 5* |
| 4** | 5* | 5* | 5*** | 5* | 5* | 5* | 5** | 5 | 5* |
| 6** | 6* | 6* | 6*** | 6* | 6* | 6* | 6** | 6 | 6* |
| 6** | 6* | 6* | 6*** | 6* | 6* | 6* | 6** | 6 | 6* |
| 6** | 6* | 6* | 6*** | 6* | 6* | 6* | 6** | 6 | 6* |
| 6** | 6* | 6* | 6*** | 6* | 6* | 6* | 6** | 6 | 6* |
| 6** | 6* | 6* | 6*** | 6* | 6* | 6* | 6** | 6 | 6* |
| 9 | 6* | 9 | 6*** | – | 6* | 9 | – | 6 | 9 |
| 6** | 6* | – | 6*** | 6* | 6* | 6* | 6** | 6 | 6* |
| 6** | 6* | – | 6*** | 6* | 6* | 6* | 6** | 6 | 6* |
| 6** | 6* | – | 6*** | 6* | 6* | 6* | 6** | 6 | 6* |
| 6** | 6* | – | 6*** | 6* | 6* | 6* | 6** | 6 | 6* |
| 3* | 3* | | | | 3* | | | 3 | |



ATTENTION
Bulbs for Navigation Lights
 The bulbs used in Navigation Lights are part of the approval/certification.
 Bulbs which are non-approved null-invoid your insurance cover as your lights will not be in line with the regulations/certification.
We recommend to use approved material only since this is in the interest of your safety.

ACHTUNG
Glühlampen für Navigationslaternen
 Die in Navigationslaternen verwendeten Glühlampen sind Teil der Zulassung.
 Reservelühlampen müssen ebenfalls zugelassen sein. Im Versicherungsfall riskieren Sie den Verlust Ihrer Versicherungsdeckung wenn sich herausstellt, daß Ihre Ausrüstung nicht den Vorschriften entspricht.
Wir empfehlen im Interesse Ihrer Sicherheit nur zugelassenes Material zu verwenden.

- 1 for all vessels of less than 7 m
- 2 for all vessels of less than 12 m
- 3 for all vessels of less than 20 m
- 4 for all vessels of less than 50 m
- 5 for power driven vessels > 20 - < 50 m
- 6 for power driven vessels of 20 m and above
- 7 for power driven vessels < 12 m
- 8 navigation lights for recreational boating need no national approval
- 9 approval pending

- * type approval, no individual certificates
- ** individual certificates (see remarks)
- *** one certificate per supply
- **** type approval for recreational, no individual certificate

Official individual certificates, issued by government authorities are available from Italy, Peoples Republic of China and Russia.
 Where required works certificates or copies of approval documents may be issued.

- 1 für alle Wasserfahrzeuge kleiner als 7 m
- 2 für alle Wasserfahrzeuge kleiner als 12 m
- 3 für alle Wasserfahrzeuge kleiner als 20 m
- 4 für alle Wasserfahrzeuge kleiner als 50 m
- 5 für motorbetriebene Wasserfahrzeuge > 20 - < 50 m
- 6 für motorbetriebene Wasserfahrzeuge von 20 m und darüber
- 7 für motorbetriebene Wasserfahrzeuge < 12 m
- 8 Navigationslaternen der Sportschifffahrt, die keine nationale Zulassung benötigen
- 9 in Bearbeitung

- * Typenzulassung, keine Einzelzertifikate
- ** Einzelzertifikate (siehe Hinweis)
- *** 1 Zertifikat pro Lieferung
- **** Typenzulassung für die Sportschifffahrt, keine Einzelzertifikate

Offizielle Einzelzertifikate, ausgestellt von den dazu autorisierten Regierungsstellen, gibt es nur für die Länder, Italien, Volksrepublik China und Russland. Die Kosten für diese Zertifikate sind Veränderungen unterworfen und wo erforderlich, können Werkszertifikate oder Kopien von Zulassungszeugnissen bestellt werden.