

# J2K100 J1939 to NMEA 2000® Gateway

## User's Manual

Revision 1.2

**Warning:** *Improper installation of the Maretron J2K100 may prevent existing engine accessories (i.e., engine gauge displays, key switches, throttle and shift controls, etc.) from working properly. You must have an understanding of J1939 data networks before attempting to install the J2K100. Maretron strongly recommends that you understand SAE documents J1939-11 and J1939-15 (see Section 3.1 of Appendix B) before attempting to install the J2K100 and that you consult the engine/genset manufacture for their recommendations before connecting anything to the J1939 network.*

**Copyright © 2009 Maretron, LLP All Rights Reserved**

**Maretron, LLP  
9014 N. 23<sup>rd</sup> Ave #10  
Phoenix, AZ 85021-7850  
<http://www.maretron.com>**

**Maretron Manual Part #: M001201**

## Revision History

Revision	Description
1.0	Original document
1.1	Changed address on cover page
	Added warning on cover page
	Miscellaneous editorial changes
	Added Appendix B
1.2	Changed cable part numbers in Appendix B to reflect new Maretron part #'s
	Inserted new figure showing J1939 connection diagram
	Added new translations to Section 5 (Technical Specifications)
	Updated Mounting Drawings and Mounting Template for new (black) enclosure

## Table of Contents

1	Introduction .....	1
1.1	Firmware Revision.....	1
1.2	J2K100 Features .....	1
1.3	Quick Install.....	1
2	Installation .....	2
2.1	Unpacking the Box .....	2
2.2	Choosing a Mounting Location .....	2
2.3	Mounting the J2K100.....	2
2.4	Connecting the J2K100 .....	3
2.4.1	Connecting the J2K100 NMEA 2000® Interface.....	3
2.4.2	Connecting the J2K100 J1939 Interface.....	4
2.4.3	Checking Connections.....	5
2.5	Configuring the J2K100 .....	5
2.5.1	J1939 Source Address Selection.....	5
2.5.2	NMEA 2000® Engine Instance Selection .....	5
2.5.3	NMEA 2000® Transmission Instance Selection .....	6
2.5.4	J1939 Diagnostic Messages Enable/Disable.....	6
2.5.5	NMEA 2000® PGN Enable/Disable.....	6
3	Maintenance.....	7
4	Troubleshooting.....	7
5	Technical Specifications.....	8
6	Technical Support .....	10
7	Installation Template .....	11
8	Maretron (2 Year) Limited Warranty .....	12

## Table of Figures

Figure 1	– Mounting the J2K100.....	2
Figure 3	– J2K100 Electrical Connections.....	3
Figure 4	– NMEA 2000® Connector Face Views .....	4
Figure 6	– Mounting Surface Template .....	11

## Table of Appendices

Appendix A	– NMEA 2000® Interfacing Translations .....	A1
Appendix B	– Application Note .....	B1

This Page Intentionally Left Blank

## 1 Introduction

Congratulations on your purchase of the Maretron J1939 to NMEA 2000® Gateway (J2K100). Maretron has designed and built your gateway to the highest standards for years of dependable and accurate service.

Maretron's J2K100 is a gateway for bridging J1939-equipped engines and gensets with an NMEA 2000® network. The gateway automatically converts incoming J1939 messages to NMEA 2000® messages so you can monitor your J1939-equipped engines, transmissions, or gensets with networked NMEA 2000® displays such as the Maretron DSM200 or DSM250.

The Maretron J2K100 is designed to operate within the harsh demands of the marine environment. However, no piece of marine electronic equipment can function properly unless installed, configured, and maintained in the correct manner. Please read carefully and follow these instructions for installation, configuration, and usage of the Maretron J2K100 in order to ensure optimal performance.

### 1.1 Firmware Revision

This manual corresponds to J2K100 firmware revision 1.0.8.

### 1.2 J2K100 Features

The Maretron J2K100 has the following features.

- NMEA 2000® and J1939 Interfaces
- Waterproof Connectors
- Sealed Waterproof Enclosure
- Translates J1939 Engine and Transmission Messages to Equivalent NMEA 2000® Messages
- Capable of Passing J1939 Diagnostic Messages
- Passes J1939 AC Generator Parameters through to the NMEA 2000® network
- J1939 Interface is Opto-Isolated from NMEA 2000® Eliminating Potential Ground Loops
- Obtains Power from NMEA 2000® Port (No power drawn from or data transmitted on J1939 interface).

### 1.3 Quick Install

Installing the Maretron J2K100 gateway involves the following five steps. Please refer to the individual sections for additional details.

1. Unpack the Box (Section 2.1)
2. Choose a Mounting Location (Section 2.2)
3. Mount the J2K100 (Section 2.3)
4. Connect the J2K100 (Section 2.4)
5. Configure the J2K100 - Optional, only required for specialized configurations (Section 2.5)

## **2 Installation**

### **2.1 Unpacking the Box**

When unpacking the box containing the Maretron J2K100, you should find the following items:

- 1 – J2K100 - J1939 to NMEA 2000® Gateway
- 4 – Mounting Screws
- 1 – Female Micro Field-Attachable Connector (For connecting J1939 interface)
- 1 – J2K100 User's Manual
- 1 – Warranty Registration Card

If any of these items are missing or damaged, please contact Maretron.

### **2.2 Choosing a Mounting Location**

The J2K100 is mounted between the J1939 network and the NMEA 2000® network. Please consider the following when choosing a mounting location.

1. The J2K100 is waterproof, so it can be mounted in a damp or dry location.
2. The orientation is not important, so the J2K100 can be mounted on a horizontal deck, vertical bulkhead, or even upside down if desired.
3. The J2K100 is temperature rated to 55°C (130°F), so it should be mounted away from engines or engine rooms where the operating temperature exceeds the specified limit.

### **2.3 Mounting the J2K100**

Attach the J2K100 securely to the vessel using the included brass mounting screws or other fasteners as shown in Figure 1 below.

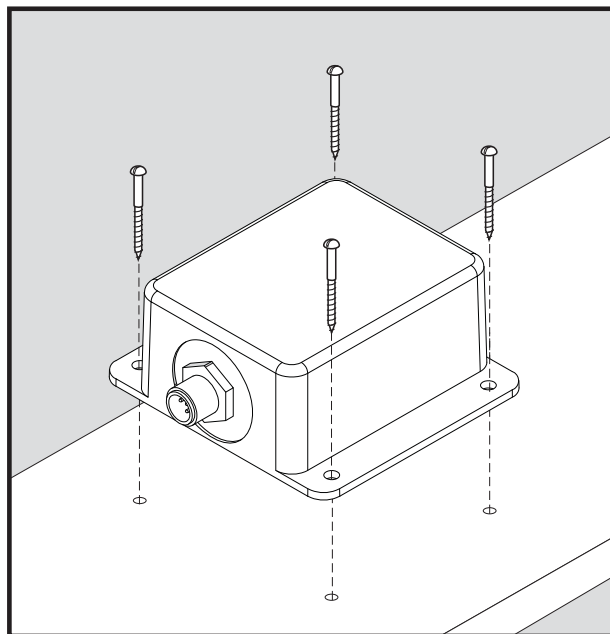

***Figure 1 – Mounting the J2K100***

## 2.4 Connecting the J2K100

The J2K100 requires two electrical connections as shown in Figure 2. Refer to Section 2.4.1 for making the NMEA 2000® connection and Section 2.4.2 for making the J1939 connection. Additional information can be found in Appendix B - Interfacing J1939 Engines and/or Gensets to an NMEA 2000® Network Using Maretron's J1939 to NMEA 2000® Gateway (J2K100).

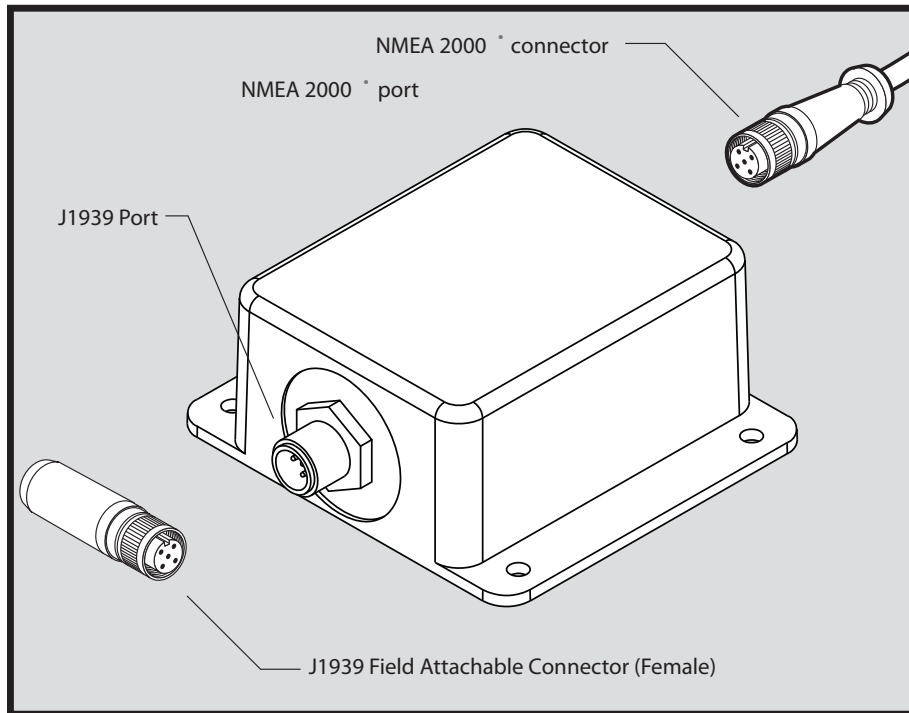

**Figure 2 – J2K100 Electrical Connections**

### 2.4.1 Connecting the J2K100 NMEA 2000® Interface

Vertical text on the J2K100 label identifies the NMEA 2000® connector. With the label right side up, the NMEA 2000® connector can be found on the right side of the enclosure. The NMEA 2000® connector is a five pin male connector (see Figure 3). You connect the J2K100 to an NMEA 2000® network using a Maretron NMEA 2000® cable (or compatible cable) by connecting the female end of the cable to the J2K100 (note the key on the male connector and keyway on the female connector). Be sure the cable is connected securely and that the collar on the cable connector is tightened firmly. Connect the other end of the cable (male) to the NMEA 2000® network in the same manner. The J2K100 is designed such that you can plug or unplug it from an NMEA 2000® network while the power to the network is connected or disconnected. Please follow recommended practices for installing NMEA 2000® network products. See Figure 3 for NMEA 2000® connector pin assignments.

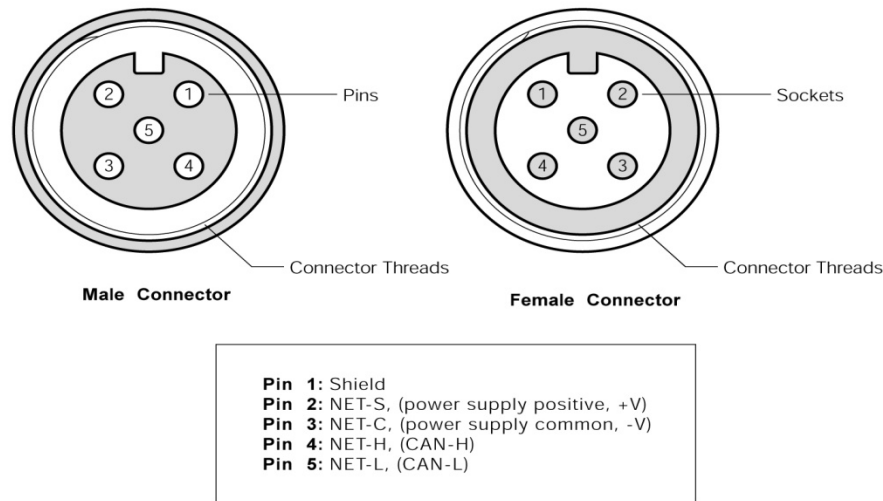
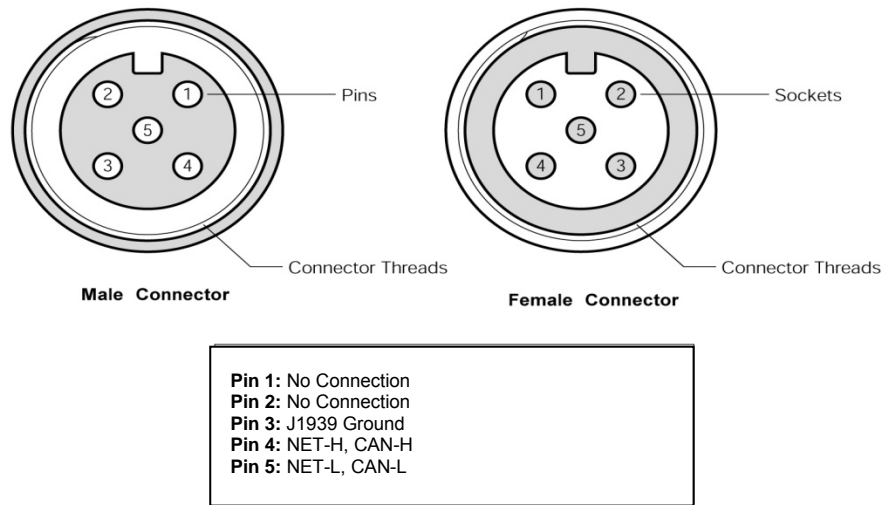

**Figure 3 – NMEA 2000® Connector Face Views**

## 2.4.2 Connecting the J2K100 J1939 Interface

Vertical text on the J2K100 label identifies the J1939 connector. With the label right side up, the J1939 connector can be found on the left side of the enclosure. In order to make the J1939 connection, you will need to locate the supplied female field attachable connector. This connector is fitted to one end of a 3-conductor cable (not supplied). Make the connections between the 3-conductor cable and the field attachable connector by following the instruction contained within the bag. Although the field attachable connector has 5 terminals, you only need to connect the CAN bus signals and ground signal (NET-H, white terminal; NET-L, blue terminal; and ground (or NET-C), black terminal). The other end of the 3-conductor cable needs to be tied into the J1939 network. You will need to identify the CAN bus signals on the J1939 network by reviewing the manufacturer's documentation. Most likely, they will identify the CAN bus signals as CAN-H and CAN-L which correspond to the field attachable terminals NET-H and NET-L respectively. You will also need to connect the NET-C or ground signal found within the field attachable connector to the J1939 ground connection. See Figure 4 for J1939 connector pin assignments





**Figure 4 – J1939 Connector Face Views**

### 2.4.3 Checking Connections

Once the NMEA 2000® and J1939 connections to the J2K100 have been completed, check to see that information is being properly transmitted by observing an appropriate NMEA 2000® display. If you don't see engine and/or generator data, refer to Section 4, "Troubleshooting".

## 2.5 Configuring the J2K100

As shipped from the factory, the J2K100 does not require any special configuration and will work for most applications. However, there are several configurable items within the J2K100, including: 1) J1939 source address selection, 2) NMEA 2000® engine instance selection, 3) NMEA 2000® transmission instance selection, 4) J1939 diagnostic messages enable/disable, and 4) NMEA 2000® PGN enable/disable.

### 2.5.1 J1939 Source Address Selection

The J2K100 connects into a J1939 network and translates messages from a single J1939 device into NMEA 2000® messages. By default, the J2K100 only translates J1939 messages from a J1939 device with a source address of zero. If the J1939 source address of the engine, transmission, or genset to be monitored is different than zero, then the J2K100 must be programmed with the appropriate J1939 source address. This can be done with the Maretron DSM200 or DSM 250 displays or other NMEA 2000® display unit that is capable of configuring the J2K100. Please refer to the Maretron *DSM200 User's Manual* or *DSM250 User's Manual*, as appropriate, for details.

### 2.5.2 NMEA 2000® Engine Instance Selection

NMEA 2000® provides a unique engine instance for each engine on a vessel. Single engine vessels use engine instance zero (0) while dual engine vessels use engine instance zero (0)

for the port engine and engine instance one (1) for the starboard engine. By default, the J2K100 uses engine instance zero (0). If you are installing the J2K100 on a single engine vessel, then you don't have to configure this parameter. However, if you install two J2K100s for dual engine vessels, then you will need to configure the starboard engine J2K100 to use engine instance one (1). You configure the J2K100 using a Maretron DSM200 or DSM250 display or other NMEA 2000<sup>®</sup> display unit that is capable of configuring the J2K100. Please refer to the Maretron *DSM200 User's Manual* or *DSM250 User's Manual*, as appropriate, for details.

### **2.5.3 NMEA 2000<sup>®</sup> Transmission Instance Selection**

NMEA 2000<sup>®</sup> provides a unique transmission instance for each transmission on a vessel. Single transmission vessels use transmission instance zero (0) while dual transmission vessels use transmission instance zero (0) for the port transmission and transmission instance one (1) for the starboard transmission. By default the J2K100 uses transmission instance zero (0). If you are installing the J2K100 on a single transmission vessel, then you don't have to configure this parameter. However, if you install two J2K100s for dual transmission vessels, then you will need to configure the starboard transmission J2K100 to use transmission instance one (1). You configure the J2K100 using a Maretron DSM200 or DSM250 display or other NMEA 2000<sup>®</sup> display unit that is capable of configuring the J2K100. Please refer to the Maretron *DSM200 User's Manual* or *DSM250 User's Manual*, as appropriate, for details.

### **2.5.4 J1939 Diagnostic Messages Enable/Disable**

The J2K100 is capable of re-broadcasting J1939 diagnostic messages output by the monitored engine, transmission, or genset onto the NMEA 2000<sup>®</sup> network. As shipped from the factory, the J2K100 does not transmit J1939 diagnostic messages over the NMEA 2000<sup>®</sup> network. If this behavior is desired, it may be enabled with the Maretron DSM200 or DSM250 display or other NMEA 2000<sup>®</sup> display unit that is capable of configuring the J2K100. Please refer to the Maretron *DSM200 User's Manual* or *DSM250 User's Manual*, as appropriate, for details.

### **2.5.5 NMEA 2000<sup>®</sup> PGN Enable/Disable**

The J2K100 is capable of transmitting several different kinds of NMEA 2000<sup>®</sup> messages (or PGNs) associated with engines, transmissions, and gensets. The J2K100 automatically detects incoming messages from the J1939 network and translates them into corresponding NMEA 2000<sup>®</sup> PGNs. For example, if the J2K100 receives engine-related messages from the J1939 network but no transmission or genset messages, then the J2K100 will generate the corresponding NMEA 2000<sup>®</sup> engine PGNs, but it will not transmit any NMEA 2000<sup>®</sup> transmission or genset messages. As another example, let's say that there is an engine and a genset connected to the J1939 network, yet we are only interested in having the engine messages translated to corresponding NMEA 2000<sup>®</sup> PGNs. In this case, the J2K100 can be configured to enable engine PGNs while disabling genset PGNs. You can configure the J2K100 using a Maretron DSM200 or DSM250 display or other NMEA 2000<sup>®</sup> display unit that is capable of configuring the J2K100. Please refer to the Maretron *DSM200 User's Manual* or *DSM250 User's Manual*, as appropriate, for details.

## 3 Maintenance

Regular maintenance is important to ensure continued proper operation of the Maretron J2K100. Perform the following tasks periodically:

- Clean the unit with a soft cloth. Do not use chemical cleaners as they may remove paint or markings or may corrode the J2K100 enclosure or seals.
- Ensure that the unit is mounted securely and cannot be moved relative to the mounting surface. If the unit is loose, tighten the mounting screws.
- Check the security of the cable connected to the NMEA 2000® and J1939 connectors and tighten if necessary.

## 4 Troubleshooting

If you notice unexpected operation of the Maretron J2K100, follow the troubleshooting procedures in this section to remedy simple problems. If these steps do not solve your problem, please contact Maretron Technical Support (refer to Section 6 for contact information).

Symptom	Troubleshooting Procedure
<p>No engine, transmission or genset data visible on NMEA 2000® network.</p>	<p>Ensure that the J1939 network is operational by observing J1939 gauges or displays. You should see information transmitted from the engine, transmission, or genset displayed on the J1939 displays. If you don't see data, try disconnecting the J1939 connection you made to the J2K100 as something may have been connected incorrectly.</p> <p>Once you are sure that the J1939 network is operational with a J2K100 connected, ensure that the NMEA 2000® network is operational by observing displays. You should see information from components besides the ones attached to the J2K100 which verifies an operational NMEA 2000® network. If you don't see data, try disconnecting the NMEA 2000 connection you made to the J2K100 as something may have been connected incorrectly.</p> <p>Once you are sure that the J1939 and NMEA 2000 networks are operational with a connected J2K100, ensure that the NMEA 2000® connector is securely connected to the NMEA 2000® network and the J1939 connector is securely connected to the J1939 network.</p> <p>Ensure that the J2K100 has the appropriate NMEA 2000® PGNs enabled as described in Section 2.5.5.</p> <p>Ensure that the J2K100 is programmed with an engine or transmission J1939 source address that corresponds to the J1939 source addressed used by the connected engine or genset as described in Section 2.5.1.</p>

*Warning: There are no user-serviceable components inside the Maretron J2K100. Opening the J2K100 will expose the sensitive electronic components to adverse environmental conditions that may render the unit inoperative. Please do not open the J2K100, as this will automatically void the warranty. If service is required, please return the unit to an authorized Maretron service location.*

## **5 Technical Specifications**

As Maretron is constantly improving its products, all specifications are subject to change without notice. Maretron products are designed to be accurate and reliable; however, they should be used only as aids to navigation and not as a replacement for traditional navigation aids and techniques.

## J1939 Data Translated to NMEA 2000® Data

J1939 SPN/PGN	Description	NMEA 2000® PGN
190 / 61444	Engine Speed	127488
102 / 65270	Engine Turbocharger Boost Pressure	127488
100 / 65263	Engine Oil Pressure	127489
175 / 65262	Engine Oil Temperature 1	127489
110 / 65262	Engine Coolant Temperature	127489
167 / 65271	Alternator Potential (Voltage)	127489
183 / 65266	Engine Fuel Rate	127489
247 / 65253	Engine Total Hours of Operation	127489
109 / 65263	Engine Coolant Pressure	127489
94 / 65263	Engine Fuel Delivery Pressure	127489
92 / 61443	Engine Percent Load at Current Speed	127489
513 / 61444	Actual Engine – Percent Torque	127489
168 / 65271	Electrical Potential (Voltage)	127489
158 / 65271	Battery Potential (Voltage), Switch	127489
189 / 65214	Engine Rated Speed	127498
237 / 65260	Vehicle Identification Number	127498
234 / 65242	Software Identification	127498
523 / 61445	Transmission Current Gear	127493
127 / 65272	Transmission Oil Pressure	127493
177 / 65272	Transmission Oil Temperature	127493

## Certifications

Parameter	Comment
NMEA 2000®	Level B+
Maritime Navigation and Radiocommunication Equipment & Systems	IEC 60945
FCC and CE Mark	Electromagnetic Compatibility

## NMEA 2000® Parameter Group Numbers (PGNs)

Description	PGN #	PGN Name	Default Rate
Periodic Data PGNs	127488	Engine Parameters, Rapid Update	10 times/second
	127489	Engine Parameters, Dynamic	1 time/second
	127498	Engine Parameters, Static	N/A
	127493	Transmission Parameters, Dynamic	10 times/second
	65030	J1939 Generator Average Basic AC Quantities	10 times/second
	65226	J1939 Diagnostic Message #1	N/A
	65227	J1939 Diagnostic Message #2	N/A
	65228	J1939 Diagnostic Message #3	N/A
	65229	J1939 Diagnostic Message #4	N/A
	65230	J1939 Diagnostic Message #5	N/A
	65231	J1939 Diagnostic Message #6	N/A
	65232	J1939 Diagnostic Message #8	N/A
	65234	J1939 Diagnostic Message #10	N/A
	65235	J1939 Diagnostic Message #11	N/A
65236	J1939 Diagnostic Message #12	N/A	
Response to Requested PGNs	126464	PGN List (Transmit and Receive)	N/A
	126996	Product Information	N/A
	126998	Configuration Information	N/A
Protocol PGNs	059392	ISO Acknowledge	N/A
	059904	ISO Request	N/A
	060928	ISO Address Claim	N/A
	065240	ISO Address Command	N/A
	126208	NMEA	N/A

# J2K100 User's Manual

Maretron Proprietary PGN's	128720	Configuration	N/A
----------------------------	--------	---------------	-----

## Electrical

Parameter	Value	Comment
Operating Voltage	9 to 16 Volts	DC Voltage
Power Consumption	<150mA	Average Current Drain
Load Equivalence Number (LEN)	3	NMEA 2000 <sup>®</sup> Spec. (1LEN = 50 mA)
Reverse Battery Protection	Yes	Indefinitely
Load Dump Protection	Yes	Energy Rated per SAE J1113

## Mechanical

Parameter	Value	Comment
Size	4.50" x 3.20" x 2.09"	Including Flanges for Mounting
Weight	8 oz.	

## Environmental

Parameter	Value
IEC 60954 Classification	Exposed
Degree of Protection	IP66
Operating Temperature	-25°C to 55°C
Storage Temperature	-40°C to 70°C
Relative Humidity	93%RH @40° per IEC60945-8.2
Vibration	2-13.2Hz @ ±1mm, 13.2-100Hz @ 7m/s <sup>2</sup> per IEC 60945-8.7
Rain and Spray	12.5mm Nozzle @ 100liters/min from 3m for 30min per IEC 60945-8.8
Solar Radiation	Ultraviolet B, A, Visible, and Infrared per IEC 60945-8.10
Corrosion (Salt Mist)	4 times 7days @ 40°C, 95%RH after 2 hour Salt Spray Per IEC 60945-8.12
Electromagnetic Emission	Conducted and Radiated Emission per IEC 60945-9
Electromagnetic Immunity	Conducted, Radiated, Supply, and ESD per IEC 60945-10
Safety Precautions	Dangerous Voltage, Electromagnetic Radio Frequency per IEC 60945-12

## 6 Technical Support

If you require technical support for Maretron products, you can reach us in any of the following ways:

Telephone: 1-866-550-9100  
Fax: 1-602-861-1777  
E-mail: [support@maretron.com](mailto:support@maretron.com)  
World Wide Web: <http://www.maretron.com>  
Mail: Maretron, LLP  
Attn: Technical Support  
9014 N. 23<sup>rd</sup> Ave Suite 10  
Phoenix, AZ 85021 USA

## 7 Installation Template

Please check the dimensions before using the following diagram as a template for drilling the mounting holes because the printing process may have distorted the dimensions.

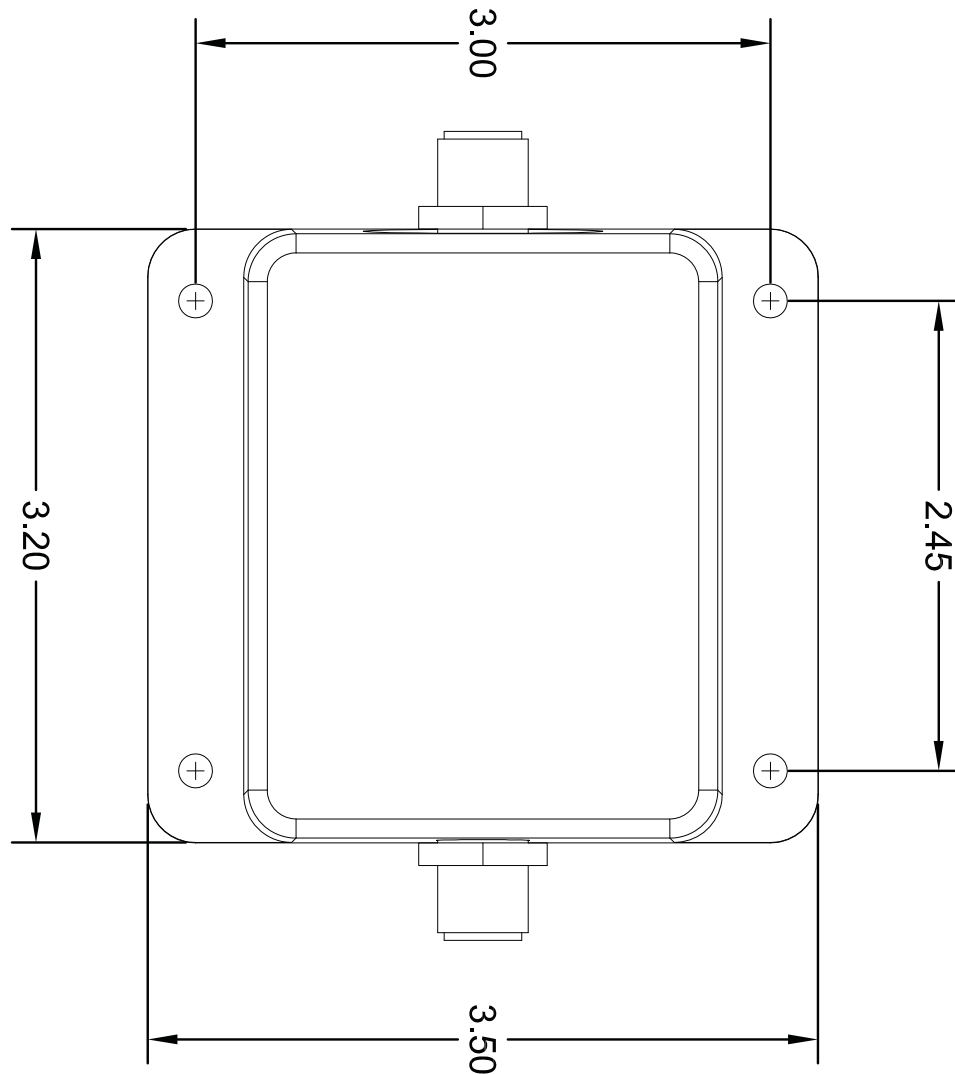

**Figure 5 – Mounting Surface Template**

### **8 Maretron (2 Year) Limited Warranty**

Maretron warrants the J2K100 to be free from defects in materials and workmanship for **two (2) years** from the date of original purchase. If within the applicable period any such products shall be proved to Maretron's satisfaction to fail to meet the above limited warranty, such products shall be repaired or replaced at Maretron's option. Purchaser's exclusive remedy and Maretron's sole obligation hereunder, provided product is returned pursuant to the return requirements below, shall be limited to the repair or replacement, at Maretron's option, of any product not meeting the above limited warranty and which is returned to Maretron; or if Maretron is unable to deliver a replacement that is free from defects in materials or workmanship, Purchaser's payment for such product will be refunded. Maretron assumes no liability whatsoever for expenses of removing any defective product or part or for installing the repaired product or part or a replacement therefore or for any loss or damage to equipment in connection with which Maretron's products or parts shall be used. With respect to products not manufactured by Maretron, Maretron's warranty obligation shall in all respects conform to and be limited to the warranty actually extended to Maretron by its supplier. The foregoing warranties shall not apply with respect to products subjected to negligence, misuse, misapplication, accident, damages by circumstances beyond Maretron's control, to improper installation, operation, maintenance, or storage, or to other than normal use or service.

THE FOREGOING WARRANTIES ARE EXPRESSLY IN LIEU OF AND EXCLUDES ALL OTHER EXPRESS OR IMPLIED WARRANTIES, INCLUDING BUT NOT LIMITED TO THE IMPLIED WARRANTIES OF MERCHANTABILITY AND OF FITNESS FOR A PARTICULAR PURPOSE.

Statements made by any person, including representatives of Maretron, which are inconsistent or in conflict with the terms of this Limited Warranty, shall not be binding upon Maretron unless reduced to writing and approved by an officer of Maretron.

IN NO CASE WILL MARETRON BE LIABLE FOR INCIDENTAL OR CONSEQUENTIAL DAMAGES, DAMAGES FOR LOSS OF USE, LOSS OF ANTICIPATED PROFITS OR SAVINGS, OR ANY OTHER LOSS INCURRED BECAUSE OF INTERRUPTION OF SERVICE. IN NO EVENT SHALL MARETRON'S AGGREGATE LIABILITY EXCEED THE PURCHASE PRICE OF THE PRODUCT(S) INVOLVED. MARETRON SHALL NOT BE SUBJECT TO ANY OTHER OBLIGATIONS OR LIABILITIES, WHETHER ARISING OUT OF BREACH OF CONTRACT OR WARRANTY, TORT (INCLUDING NEGLIGENCE), OR OTHER THEORIES OF LAW WITH RESPECT TO PRODUCTS SOLD OR SERVICES RENDERED BY MARETRON, OR ANY UNDERTAKINGS, ACTS OR OMISSIONS RELATING THERETO.

Maretron does not warrant that the functions contained in any software programs or products will meet purchaser's requirements or that the operation of the software programs or products will be uninterrupted or error free. Purchaser assumes responsibility for the selection of the software programs or products to achieve the intended results, and for the installation, use and results obtained from said programs or products. No specifications, samples, descriptions, or illustrations provided Maretron to Purchaser, whether directly, in trade literature, brochures or other documentation shall be construed as warranties of any kind, and any failure to conform with such specifications, samples, descriptions, or illustrations shall not constitute any breach of Maretron's limited warranty.

#### **Warranty Return Procedure:**

To apply for warranty claims, contact Maretron or one of its dealers to describe the problem and determine the appropriate course of action. If a return is necessary, place the product in its original packaging together with proof of purchase and send to an Authorized Maretron Service Location. You are responsible for all shipping and insurance charges. Maretron will return the replaced or repaired product with all shipping and handling prepaid except for requests requiring expedited shipping (i.e. overnight shipments). Failure to follow this warranty return procedure could result in the product's warranty becoming null and void.

Maretron reserves the right to modify or replace, at its sole discretion, without prior notification, the warranty listed above. To obtain a copy of the then current warranty policy, please go to the following web page:

<http://www.maretron.com/company/warranty.php>



## Appendix A – NMEA 2000® Interfacing

### J2K100 NMEA 2000® Periodic Data Transmitted PGNs

#### ***PGN 127488 – Engine Parameters, Rapid Update***

The J2K100 uses this PGN to transmit rapidly changing engine data.

- Field 1: Engine Instance – This field indicates the particular engine for which this data applies. A single engine will have an instance of 0. Engines in multi-engine boats will be numbered starting at 0 at the bow of the boat incrementing to  $n$  going in towards the stern of the boat. For engines at the same distance from the bow are stern, the engines are numbered starting from the port side and proceeding towards the starboard side.
- 2: Engine Speed – This field indicates the rotational speed of the engine in units of  $\frac{1}{4}$  RPM.
- 3: Engine Boost Pressure – This field indicates the turbocharger boost pressure in units of 100 Pa.
- 4: Engine tilt/trim – This field indicates the tilt or trim (positive or negative) of the engine in units of 1 percent.
- 5: Reserved – This field is reserved by NMEA; therefore, the J2K100 sets all bits to a logic 1.

#### ***PGN 127489 – Engine Parameters, Dynamic***

The J2K100 uses this PGN to transmit more slowly changing engine data.

- Field 1: Engine Instance – This field indicates the particular engine for which this data applies. A single engine will have an instance of 0. Engines in multi-engine boats will be numbered starting at 0 at the bow of the boat incrementing to  $n$  going in towards the stern of the boat. For engines at the same distance from the bow are stern, the engines are numbered starting from the port side and proceeding towards the starboard side.
- 2: Engine Oil Pressure – This field indicates the oil pressure of the engine in units of 100 Pa.
- 3: Engine Oil Temperature – This field indicates the oil temperature of the engine in units of  $0.1^{\circ}\text{K}$ .
- 4: Engine Temperature – This field indicates the temperature of the engine coolant in units of  $0.1^{\circ}\text{K}$ .
- 5: Alternator Potential – This field indicates the alternator voltage in units of  $0.01\text{V}$ .
- 6: Fuel Rate – This field indicates the fuel consumption rate of the engine in units of  $0.0001$  cubic meters / hour.
- 7: Total Engine Hours – This field indicates the cumulative runtime of the engine in units of 1 second.
- 8: Engine Coolant Pressure – This field indicates the pressure of the engine coolant in units of 100 Pa.

- 9: Fuel Pressure – This field indicates the pressure of the engine fuel in units of 1000 Pa.
- 10: Reserved – This field is reserved by NMEA; therefore, the J2K100 sets all bits to a logic 1.
- 11: Engine Discrete Status 1 – This field indicates warning conditions of the engine with the following bit assignments (value of 1 indicates warning present):
  - Bit 0: Check Engine
  - Bit 1: Over Temperature
  - Bit 2: Low Oil Pressure
  - Bit 3: Low Oil Level
  - Bit 4: Low Fuel Pressure
  - Bit 5: Low System Voltage
  - Bit 6: Low Coolant Level
  - Bit 7: Water Flow
  - Bit 8: Water in Fuel
  - Bit 9: Charge Indicator
  - Bit 10: Preheat Indicator
  - Bit 11: High Boost Pressure
  - Bit 12: Rev Limit Exceeded
  - Bit 13: EGR System
  - Bit 14: Throttle Position Sensor
  - Bit 15: Emergency Stop Mode
- 12: Engine Discrete Status 2 – This field indicates warning conditions of the engine with the following bit assignments (value of 1 indicates warning present):
  - Bit 0: Warning Level 1
  - Bit 1: Warning Level 2
  - Bit 2: Power Reduction
  - Bit 3: Maintenance Needed
  - Bit 4: Engine Comm Error
  - Bit 5: Sub or Secondary Throttle
  - Bit 6: Neutral Start Protect
  - Bit 7: Engine Shutting Down
  - Bit 8-15: These bits are reserved and should be masked when read
- 13: Percent Engine Load – This field indicates the percent load of the engine in units of 1 percent.
- 14: Percent Engine Torque – This field indicates the percent torque of the engine in units of 1 percent.

### ***PGN 127498 – Engine Parameters, Static***

The J2K100 uses this PGN to transmit unchanging engine data.

Field 1: Engine Instance – This field indicates the particular engine for which this data applies. A single engine will have an instance of 0. Engines in multi-engine boats will be numbered starting at 0 at the bow of the boat incrementing to  $n$  going in towards the stern of the boat. For engines at the same distance from the bow are stern, the

engines are numbered starting from the port side and proceeding towards the starboard side.

- 2: Rated Engine Speed – This field indicates the maximum rated rotational speed of the engine in units of  $\frac{1}{4}$  RPM.
- 3: VIN – This field indicates the Vehicle Identification Number of the engine as a textual representation.
- 4: Software ID – This field indicates the version number or other identifying information for the software in the engine as a textual representation.

## **PGN 127493 – Transmission Parameters, Dynamic**

The J2K100 uses this PGN to transmit rapidly changing transmission data.

- Field 1: Transmission Instance – This field indicates the particular transmission for which this data applies. A single transmission will have an instance of 0. Transmissions in multi-transmission boats will be numbered starting at 0 at the bow of the boat incrementing to  $n$  going in towards the stern of the boat. For transmissions at the same distance from the bow are stern, the transmissions are numbered starting from the port side and proceeding towards the starboard side.
- 2: Transmission Gear – This field indicates the current gear the transmission is operating in.
  - 3: Reserved – This field is reserved by NMEA; therefore, the J2K100 sets all bits to a logic 1.
  - 4: Transmission Oil Pressure – This field indicates the oil pressure of the transmission in units of 100 Pa.
  - 5: Transmission Oil Temperature – This field indicates the oil temperature of the transmission in units of  $0.1^{\circ}\text{K}$ .
  - 6: Transmission Discrete Status – This field indicates warning conditions of the transmission with the following bit assignments (value of 1 indicates warning present):
    - Bit 0: Check Transmission
    - Bit 1: Over Temperature
    - Bit 2: Low Oil Pressure
    - Bit 3: Low Oil Level
    - Bit 4: Sail Drive
    - Bit 5-8: These bits are reserved and should be masked when read
  - 7: Reserved – This field is reserved by NMEA; therefore, the J2K100 sets all bits to a logic 1.

## **PGN 65030 – Generator Average Basic AC Quantities**

The J2K100 uses this PGN to transmit data concerning the electrical output from a genset.

- Field 1: Generator Average Line-Line AC RMS Voltage – This field indicates the average line to line voltage measured at the generator output in units of 1 Volt.
- 2: Generator Average Line-Neutral AC RMS Voltage – This field indicates the average line to neutral voltage measured at the generator output in units of 1 Volt.

- 3: Generator Average AC RMS Frequency – This field indicates the average frequency of the generated power measured at the generator output in units of 1/128 Hz.
- 4: Generator Average RMS Current – This field indicates the average current measured at the generator output in units of 1 Ampere.

## Appendix B – Application Note

### Interfacing J1939 Engines and/or Gensets to an NMEA 2000® Network Using Maretron's J1939 to NMEA 2000® Gateway (J2K100)

**Warning:** *Improper installation of the Maretron J2K100 may prevent existing engine accessories (i.e., engine gauge displays, key switches, throttle and shift controls, etc.) from working properly. You must have an understanding of J1939 data networks before attempting to install the J2K100. Maretron strongly recommends that you understand SAE documents J1939-11 and J1939-15 (see Section 3.1 of this appendix) before attempting to install the J2K100 and that you consult the engine/genset manufacturer for their recommendations before connecting anything to the J1939 network.*



## Table of Contents

1	Introduction .....	B3
2	NMEA 2000® Network Basics .....	B3
3	J1939 Network Basics.....	B4
3.1	SAE J1939 Recommended Cabling and Connectors.....	B5
4	Determining J1939 Network Type .....	B5
4.1	Single Engine/Genset, No J1939 Network Installation .....	B5
4.2	Single Engine/Genset, Single J1939 Network Installation.....	B7
4.3	Two Engines/Gensets, No J1939 Network Installation.....	B8
4.4	Two Engines/Gensets, Single J1939 Network Installation .....	B9
4.5	Two Engines/Gensets, Dual J1939 Networks Installation .....	B10

## Table of Figures

Figure 1	– Typical NMEA 2000® Network .....	B3
Figure 2	– Typical Single Engine J1939 Network .....	B4
Figure 3	– Two Engine, Single J1939 Network.....	B4
Figure 4	– Two Engine, Dual J1939 Networks.....	B5
Figure 5	– Single Engine/Genset, No J1939 Network Installation Diagram .....	B6
Figure 6	– Single Engine/Genset, Single J1939 Network Installation Diagram.....	B7
Figure 7	– Two Engines/Gensets, No J1939 Network Installation Diagram.....	B8
Figure 8	– Two Engines/Gensets, Single J1939 Network Installation Diagram .....	B9
Figure 9	– Two Engines/Gensets, Dual J1939 Network Installation Diagram.....	B10

## 1 Introduction

The Society of Automotive Engineers (SAE) has developed an electronic communication networking standard for the automotive industry called J1939, which is used on many larger diesels and some gasoline engines. Likewise, the National Marine Electronics Association (NMEA) has developed an electronic communication networking standard for the marine industry called NMEA 2000<sup>®</sup>, which is used for navigation information as well as other vessel data such as engine information. These two networks are now beginning to coincide more and more on vessels and Maretron has developed a gateway for bridging the two networks together via its J1939/NMEA 2000<sup>®</sup> gateway (J2K100). This application note provides a basic overview of the two networks and how the J2K100 is used to bridge engine and genset information from the J1939 network to an NMEA 2000<sup>®</sup> network.

## 2 NMEA 2000 Network Basics

An NMEA 2000<sup>®</sup> network consists of two or more nodes (electronic boxes) interconnected together using NMEA 2000<sup>®</sup> approved cable and connectors. A typical NMEA 2000<sup>®</sup> network is shown in Figure 1.

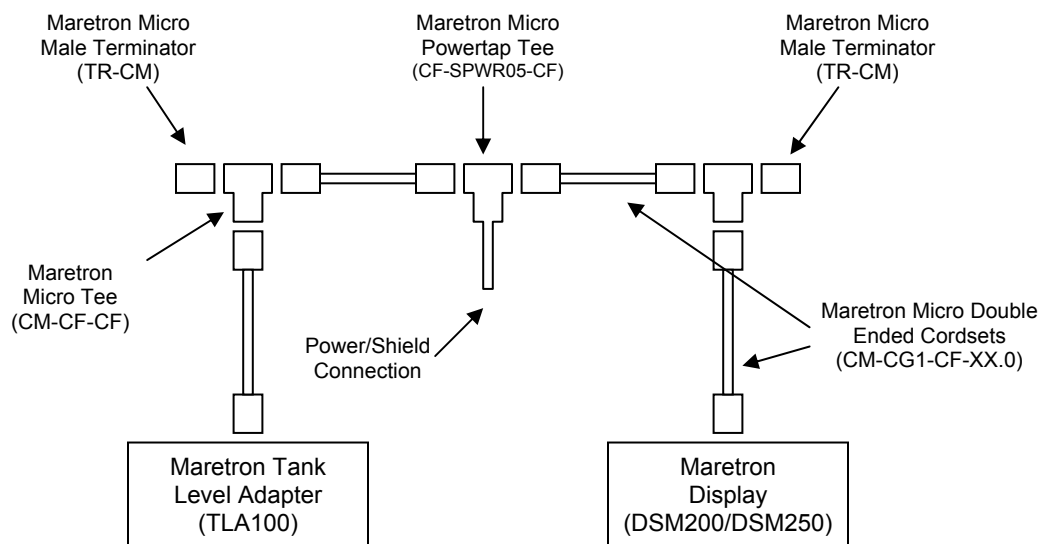

**Figure 1 – Typical NMEA 2000<sup>®</sup> Network**

The “trunk” or “backbone” (horizontal cable and connectors shown in Figure 1) usually runs stem to stern throughout the vessel with individual components connected as “drops” or “stubs” (vertical cable and connectors shown in Figure 1). NMEA 2000<sup>®</sup> networks can have as many as 50 drops throughout the vessel containing virtually any vessel information (engines, batteries, AC systems, tanks, rudder position, compass, GPS, depth, AIS data, etc.). Each end of the trunk or backbone is connected to a termination resistor (121Ω), which is used to terminate the line in its characteristic impedance to prevent reflections or ringing on the network. NMEA 2000<sup>®</sup> cables and connectors contain 5 conductors, two for power and ground (12Volts), two for data, and one for shielding.

## 3 J1939 Network Basics



Like an NMEA 2000® network, a J1939 network is based on Controller Area Network (CAN) technology. A CAN network consists of two or more nodes, and for J1939 networks, they usually include one or more engines and the corresponding engine displays. In addition to the nodes or electronic boxes, a CAN network consists of the cabling system, which is used to interconnect the nodes. At both ends of the network are terminating resistors (121Ω) that are used to terminate the line in its characteristic impedance to prevent reflections or ringing on the network. J1939 is typically wired using twisted pair for the two data lines. Figure 2 shows a typical J1939 network with a single engine and a single display.

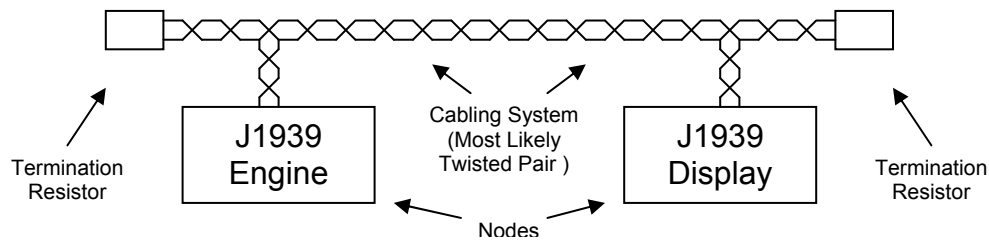

**Figure 2 - Typical Single Engine J1939 Network**

Another example showing a two engine, single J1939 network is given below in Figure 3.

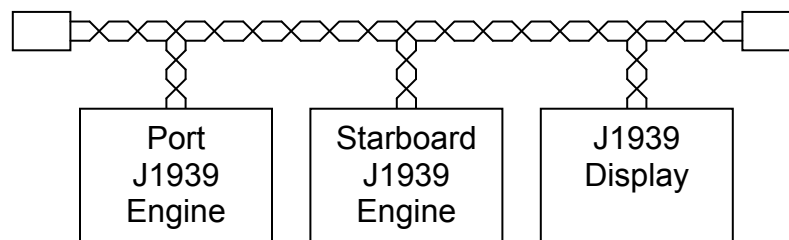

**Figure 3 – Two Engine, Single J1939 Network**

The two engine, single J1939 network shown in Figure 3 requires the individual engines to use different source addresses so that the display can distinguish which data packets or messages are associated with which engine (J1939 and NMEA 2000® refer to the messages as Parameter Group Numbers or PGNs). Usually, but not always, the port engine is assigned to address 0 while the starboard engine is assigned to address 1 by the engine manufacturer.

Another example showing two engines with, dual J1939 networks is given below in Figure 4.

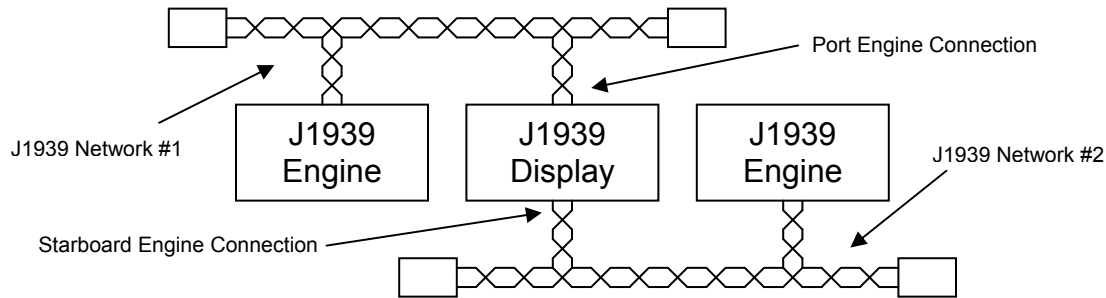

**Figure 4 – Two Engines, Dual J1939 Networks**

Unlike the single J1939 network shown in Figure 3, the dual J1939 network scheme shown in Figure 4 does not require the engines to have unique J1939 addresses. This is because the display can determine which messages or PGNs are from which engine by the physical connection on the display unit. In this scheme, each engine usually uses a source address of zero (0).

### 3.1 SAE J1939 Recommended Cabling and Connectors

Maretron highly recommends that you purchase and understand two documents published by SAE, which describe the recommended cables and connectors used for J1939 networks (approximately \$100). These documents (J1939-11 and J1939-15) provide important information for cabling and connectors used to interconnect the J2K100 with the J1939 network. You can find these documents at the following web page:

<http://www.sae.org/standardsdev/groundvehicle/j1939a.htm>

Deutsch Industrial Products Division is a supplier of J1939 connectors; their catalog can be found at the following link:

<http://www.deutschipd.com/cans.pdf>

## 4 Determining J1939 Network Type

Before installing Maretron's J2K100, it is imperative to understand the type of J1939 network you are dealing with, which may be one of the following:

1. Single Engine/Genset, No Existing J1939 Network
2. Single Engine/Genset, Single J1939 Network (Figure 2)
3. Two Engines/Gensets, No Existing J1939 Network
4. Two Engines/Gensets, Single J1939 Network (Figure 3)
5. Two Engines/Gensets, Dual J1939 Networks (Figure 4)

### 4.1 Single Engine/Genset, No Existing J1939 Network Installation

Although an engine or genset may have a J1939 interface, a particular installation may not have an existing J1939 network because no other device is connected. In this case, it will be necessary to build a J1939 network to interconnect the engine/genset with the Maretron J2K100 gateway, which can be done using NMEA 2000<sup>®</sup> cable and connectors. Figure 5 shows how to build a J1939 network using Maretron NMEA 2000<sup>®</sup> cable and connectors.

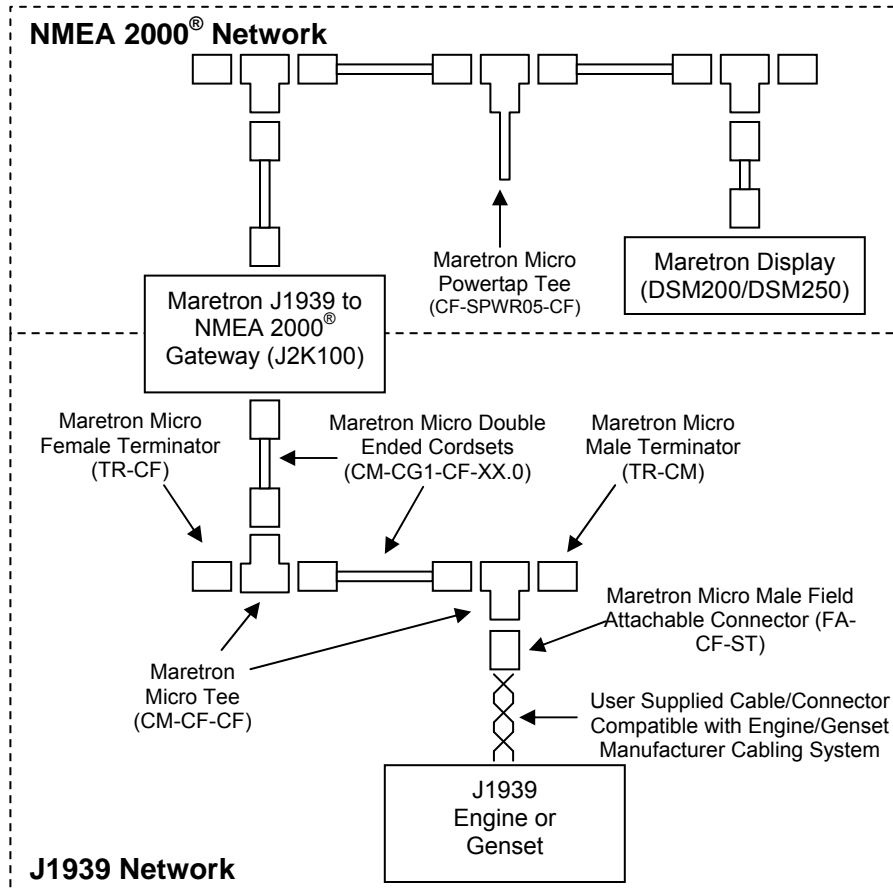

**Figure 5 – Single Engine/Genset, No J1939 Network Installation Diagram**

Although not required, this example mostly uses NMEA 2000® cable and connectors for the J1939 network. This is convenient because the network components are readily available and easily plugged together. Notice that there is no power tap in the J1939 network and this is because the J1939 engine/genset and J2K100 receive their power independent of the J1939 network. An alternative to building the J1939 network with NMEA 2000® approved cabling is to use SAE recommended cabling and connectors (see Section 3.1).

For illustration purposes, the J1939 network in Figure 5 shows the engine drop or stub (i.e., connection between engine/genset and the Maretron tee) as a two wire or twisted pair cable. The network wiring actually requires three wires: two CAN bus signals (usually designated CAN-H and CAN-L, usually yellow and green respectively), and a ground used as a reference (usually designated as CAN-SHLD). Refer to SAE J1939-11 and J1939-15 for recommended practices in connecting CAN-H, CAN-L, and CAN-SHLD.

After completing the physical connections, you will need to configure the J2K100 so it responds to the appropriate J1939 address. Most single engine installs have the J1939 address set to 0, but not always, so check with the engine manufacturer and use a Maretron NMEA 2000® display (DSM200/DSM250) to program the J2K100 with the corresponding J1939 address. On the NMEA 2000® side, most single engine displays are looking for the

NMEA 2000® instance to be set to 0. Again, you can use a Maretron display to program the appropriate NMEA 2000® instance. Refer to the *J2K100 User's Manual* (Section 2.5) for a description of configuring a J2K100.

### 4.2 Single Engine/Genset, Single J1939 Network Installation

Figure 6 shows a single engine/genset, single J1939 network installation diagram. This type of system already has a working J1939 network so there is no need to build the entire J1939 network as described in Section 4.1.

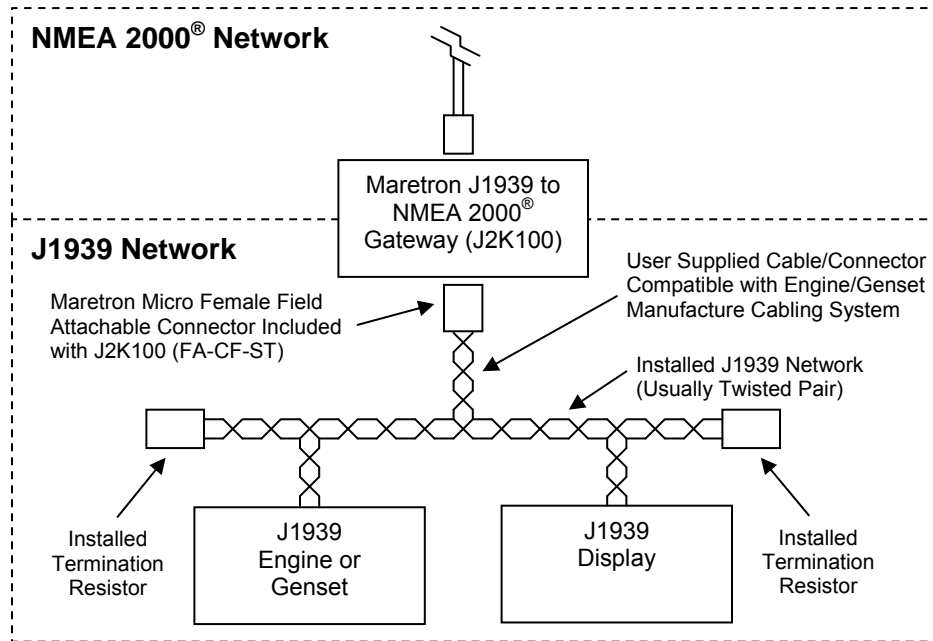

**Figure 6 – Single Engine/Genset, Single J1939 Network Installation Diagram**

This configuration requires an additional drop or stub from the J1939 trunk or backbone to the Maretron J2K100. You should follow the engine/genset manufacturer's instructions for adding the drop, which are generally specified to be 1 meter or less in length.

For illustration purposes, the J1939 network in Figure 6 shows the J2K100 drop or stub (i.e., connection between J1939 network and Maretron J2K100) as a two wire or twisted pair cable. The network wiring actually requires three wires: two CAN bus signals (usually designated CAN-H and CAN-L, usually yellow and green respectively), and a ground used as a reference (usually designated as CAN-SHLD). Refer to SAE J1939-11 and J1939-15 for recommended practices in connecting CAN-H, CAN-L, and CAN-SHLD.

After completing the physical connections, you will need to configure the J2K100 so it responds to the appropriate J1939 address. Most single engine installs have the J1939 address set to 0, but not always, so check with the engine manufacturer and use a Maretron NMEA 2000® display (DSM200/DSM250) to program the J2K100 with the corresponding J1939 address. On the NMEA 2000® side, most single engine displays are looking for the NMEA 2000® instance to be set to 0. Again, you can use a Maretron display to program the

appropriate NMEA 2000® instance. Refer to the *J2K100 User's Manual* (Section 2.5) for a detailed of configuring a J2K100.

## 4.3 Two Engines/Gensets, No Existing J1939 Network Installation

Although an engine or genset may have a J1939 interface, a particular installation may not have a J1939 network because no other device is connected. In this case, it will be necessary to build a J1939 network to interconnect the engine/genset with the Maretron J2K100 gateway, which can be done using NMEA 2000® cable and connectors. Figure 7 shows how to build a J1939 network using Maretron NMEA 2000® cable and connectors.

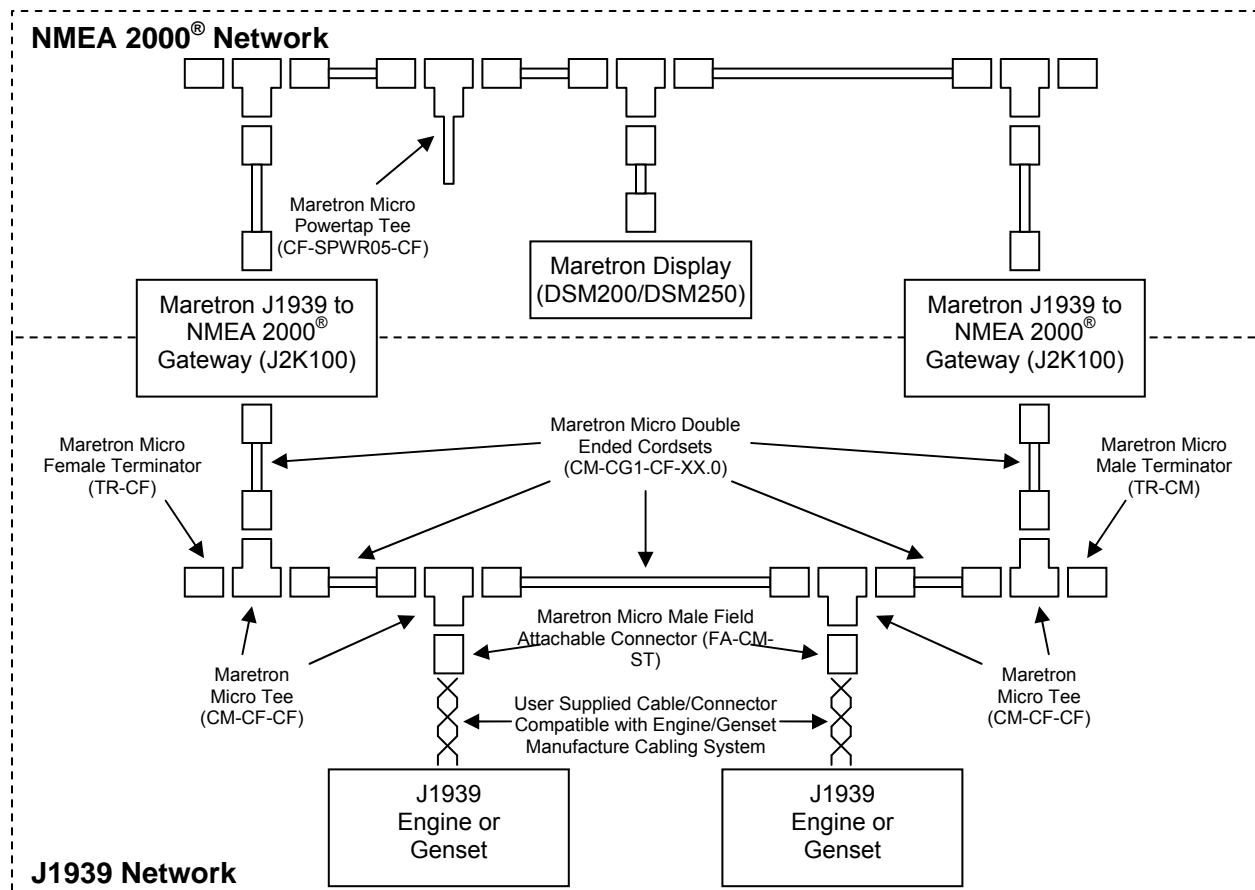

**Figure 7 – Two Engines/Gensets, No J1939 Network Installation Diagram**

Although not required, this example mostly uses NMEA 2000® cable and connectors for the J1939 network. This is convenient because the network components are readily available and easily plugged together. Notice that there is no powertap in the J1939 network and this is because the J1939 engine/genset and J2K100 receive their power independent of the J1939 network. An alternative to building the J1939 network with NMEA 2000® approved cabling is to use SAE recommended cabling and connectors (see Section 3.1).

For illustration purposes, the J1939 network in Figure 5 shows the engine drops or stubs (i.e., connections between engines/gensets and the Maretron tees) as a two wire or twisted pair

cable. The network wiring actually requires three wires, two CAN bus signals (usually designated CAN-H and CAN-L, usually yellow and green respectively) and a ground used as a reference (usually designated as CAN-SHLD). Refer to SAE J1939-11 and J1939-15 for recommended practices in connecting CAN-H, CAN-L, and CAN-SHLD.

The diagram in Figure 7 requires that the J1939 engines/gensets have unique J1939 addresses, otherwise the J2K100s won't be able to distinguish which messages or PGNs are from which engine. Check with the engine manufacturer to be sure that the J1939 interfaces on the engines/gensets have been set to different addresses. If the engines/gensets have the same address and the engine manufacturer is unable program unique addresses, you will need to build two separate J1939 networks similar to the diagram shown in Figure 9.

After completing the physical connections, you will need to configure the J2K100's so they respond to the appropriate J1939 engines/gensets. Most dual engine installs have the port engine J1939 address set to 0 and the starboard engine J1939 address set to 1, but not always, so check with the engine manufacturer and use a Maretron NMEA 2000<sup>®</sup> display (DSM200/DSM250) to program the J2K100s with the corresponding J1939 address. On the NMEA 2000<sup>®</sup> side, most dual engine displays are looking for the NMEA 2000<sup>®</sup> instance to be set to 0 for the port engine and the NMEA 2000 instance set to 1 for the starboard engine. Again, you can use a Maretron display to program the appropriate NMEA 2000<sup>®</sup> instances. Refer to the *J2K100 User's Manual* (Section 2.5) for a description of configuring a J2K100.

## 4.4 Two Engines/Gensets, Single J1939 Network Installation

Figure 8 shows a two engines/gensets, single J1939 network installation diagram.

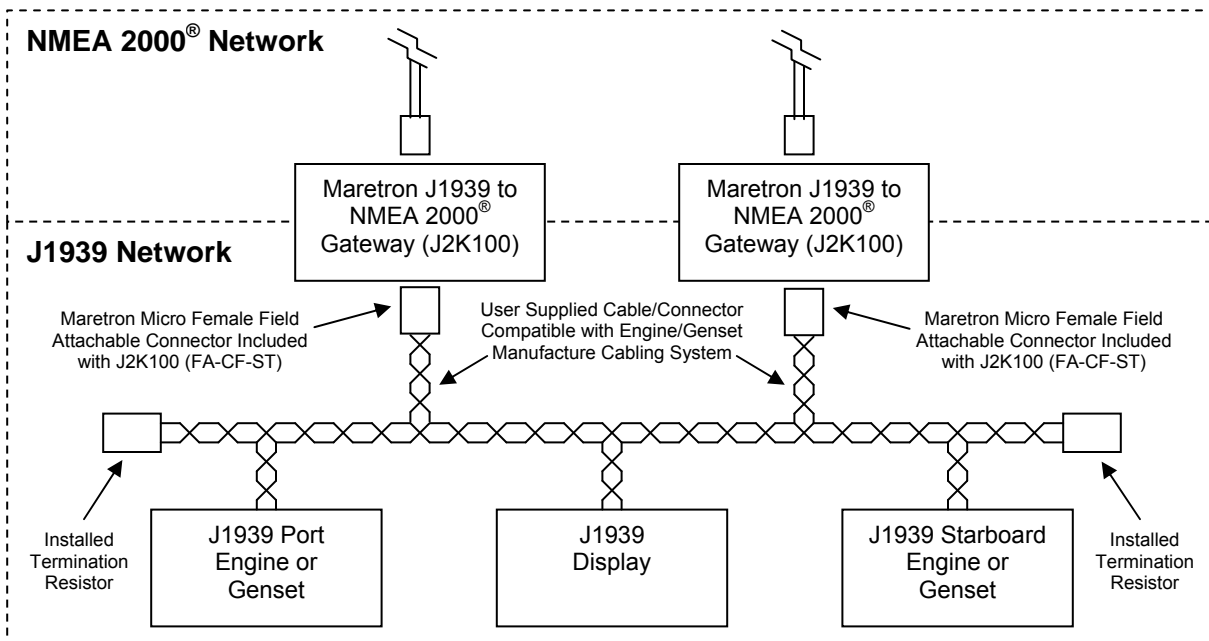

**Figure 8 – Two Engines/Gensets, Single J1939 Network Installation Diagram**

This configuration requires two additional drops or stubs from the J1939 trunk or backbone to the Maretron J2K100s. You should follow the engine/genset manufacturer's instructions for adding the drop, which are generally specified to be 1 meter or less in length.

For illustration purposes, the J1939 network in Figure 8 shows the J2K100 drops or stubs (i.e., connection between J1939 network and Maretron J2K100s) as a two wire or twisted pair cable. The network wiring actually requires three wires, two CAN bus signals (usually designated CAN-H and CAN-L, usually yellow and green respectively) and a ground used as a reference (usually designated as CAN-SHLD). Refer to SAE J1939-11 and J1939-15 for recommended practices in connecting CAN-H, CAN-L, and CAN-SHLD.

After completing the physical connections, you will need to configure the J2K100's so they respond to the appropriate J1939 engines/gensets. Most dual engine installs have the port engine J1939 address set to 0 and the starboard engine J1939 address set to 1, but not always, so check with the engine manufacturer and use a Maretron NMEA 2000® display (DSM200/DSM250) to program the J2K100s with the corresponding J1939 address. On the NMEA 2000® side, most dual engine displays are looking for the NMEA 2000® instance to be set to 0 for the port engine and the NMEA 2000 instance set to 1 for the starboard engine. Again, you can use a Maretron display to program the appropriate NMEA 2000® instances. Refer to the *J2K100 User's Manual* (Section 2.5) for a description of configuring a J2K100.

## 4.5 Two Engines/Gensets, Dual J1939 Network Installation

Figure 9 shows a two engines/gensets, dual J1939 network installation diagram.

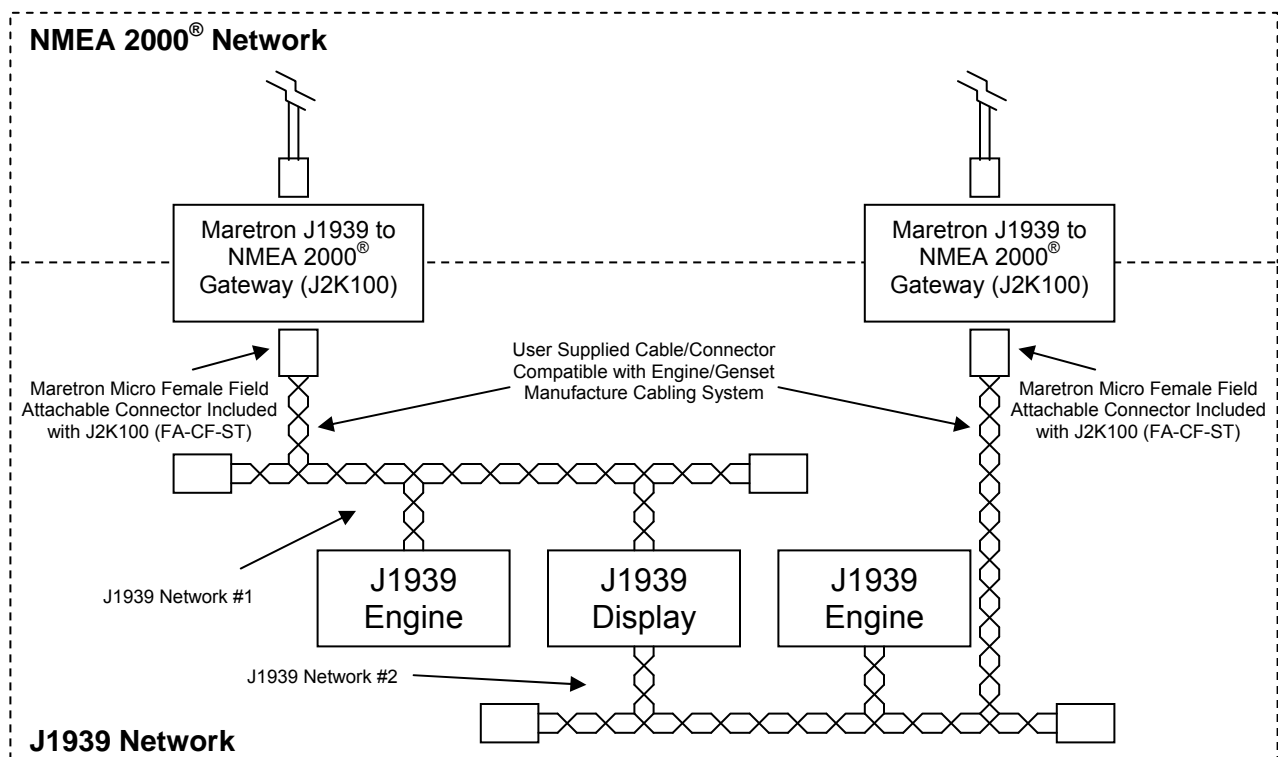

**Figure 9 – Two Engines/Gensets, Dual J1939 Network Installation Diagram**

This configuration requires two additional drops or stubs from the J1939 trunk or backbone to the Maretron J2K100s. You should follow the engine/genset manufacturer's instructions for adding the drop, which are generally specified to be 1 meter or less in length.

For illustration purposes, the J1939 network in Figure 8 shows the J2K100 drops or stubs (i.e., connection between J1939 network and Maretron J2K100s) as a two wire or twisted pair cable. The network wiring actually requires three wires: two CAN bus signals (usually designated CAN-H and CAN-L, usually yellow and green respectively), and a ground used as a reference (usually designated as CAN-SHLD). Refer to SAE J1939-11 and J1939-15 for recommended practices in connecting CAN-H, CAN-L, and CAN-SHLD.

After completing the physical connections, you will need to configure the J2K100's so they respond to the appropriate J1939 engines/gensets. Most dual engine installs have the port engine J1939 address set to 0 and the starboard engine J1939 address set to 1, but not always, so check with the engine manufacturer and use a Maretron NMEA 2000<sup>®</sup> display (DSM200/DSM250) to program the J2K100s with the corresponding J1939 address. On the NMEA 2000<sup>®</sup> side, most dual engine displays are looking for the NMEA 2000<sup>®</sup> instance to be set to 0 for the port engine and the NMEA 2000 instance set to 1 for the starboard engine. Again, you can use a Maretron display to program the appropriate NMEA 2000<sup>®</sup> instances. Refer to the *J2K100 User's Manual* (Section 2.5) for a description of configuring a J2K100.