

RAA100 Rudder Angle Adapter

User's Manual

Revision 1.0

Copyright © 2006 Maretron, LLC All Rights Reserved

**Maretron, LLC
9034 N. 23rd Ave #13
Phoenix, AZ 85021-7850
<http://www.maretron.com>**

Maretron Manual Part #: M001101

Revision History

Revision	Description
1.0	Original document

Table of Contents

1	General	1
1.1	Introduction	1
1.2	Firmware Revision	1
1.3	Features	1
1.4	Quick Install	1
2	Installation	2
2.1	Unpacking the Box.....	2
2.2	Choosing a Mounting Location	2
2.2.1	Mounting Location When Used With Analog Gauge(s).....	2
2.2.2	Mounting Location When Used Without Analog Gauge(s)	3
2.3	Connecting the RAA100	4
2.3.1	Connecting Attached Gray Cable to Analog Gauge or Rudder Sender	4
2.3.1.1	Connecting Attached Gray Cable to Analog Gauge	5
2.3.1.2	Connecting Attached Gray Cable to Rudder Angle Sender	5
2.3.2	Connecting to NMEA 2000® Interface	5
3	Configuring the RAA100	6
3.1	Configuring Rudder Instance Number	6
3.2	Configuring Operating Mode.....	7
3.2.1	Configuring Analog Gauge Resistance	7
3.2.1.1	Power Terminal to Sensor Terminal Resistance Measurement	7
3.2.1.2	Ground Terminal to Sensor Terminal Resistance Measurement.....	7
3.3	Standard Sender Selection or Custom Calibration	8
3.3.1	Standard Sender Selection	8
3.3.2	Custom Calibration.....	8
4	Maintenance.....	8
5	Troubleshooting	9
6	Technical Specifications.....	10
7	Technical Support	11
8	Maretron (2 Year) Limited Warranty	12

Table of Figures

Figure 1– Mounting Location When Used with Analog Gauge	3
Figure 2 – Mounting Location When Used Without Analog Gauge.....	4
Figure 3 – RAA100 Connections	4
Figure 4 – NMEA 2000® Connector Face Views	6
Figure 5 – Troubleshooting Guide	10

List of Tables

Table 1 – RAA100 Gauge Connections.....	5
Table 2 – RAA100 Resistive Rudder Angle Sender Connections.....	5

Table of Appendices

Appendix A – NMEA 2000® Interfacing.....	A1
--	----

1 General

1.1 Introduction

Congratulations on your purchase of the Maretron Rudder Angle Adapter (RAA100). Maretron has designed and built your adapter to the highest standards for years of reliable, dependable, and accurate service.

The RAA100 is used to adapt commercially available rudder angle senders to the NMEA 2000® network. This allows you to observe the rudder angle anywhere on the vessel where there is an NMEA 2000® compatible display such as the Maretron DSM200. The RAA100 is compatible with both the American standard (240-33 ohm) and the European standard (10-180 ohm) resistive senders and in fact, the RAA100 can be calibrated for any resistive sender with resistance values between 0 and 300 ohms. You can also use the RAA100 with analog gauges so you don't have to get rid of existing gauges to enjoy the advantages of digitally networked information.

The Maretron RAA100 is designed to operate within the harsh demands of the marine environment. However, no piece of marine electronic equipment can function properly unless installed, calibrated, and maintained in the correct manner. Please read carefully and follow these instructions for installation, calibration, and usage of the Maretron RAA100 in order to ensure optimal performance.

1.2 Firmware Revision

This manual corresponds to RAA100 firmware revision 1.2

1.3 Features

The Maretron RAA100 has the following features.

- NMEA 2000® Interface
- Adapts American standard (240-30 ohm) resistive senders to NMEA 2000® Network
- Adapts European standard (10-180 ohm) resistive senders to NMEA 2000® Network
- Can be Calibrated for any Resistive Sender Ranging from 0-300 Ohms or 300-0 Ohms
- Programmable Rudder Instance Number(s) between 0 and 251
- Works Alongside of Analog Gauges
- Can be Used Standalone Without Analog Gauges

1.4 Quick Install

Installing the Maretron RAA100 involves the following steps. Please refer to the individual sections for additional details.

1. Unpack the Box (Section 2.1)
2. Choose a Mounting Location (Section 2.2)
3. Connect the RAA100 (Section 2.3)

4. Configure or Program the Rudder Instance Number (Section 3.1)
5. Configure or Program the Operating Mode (Section 3.2)
6. Configure or Program the Resistive Sender type: American or European (Section 3.3.1)
7. Optional – Custom Calibration (Section 3.3.2)

2 Installation

2.1 Unpacking the Box

When unpacking the box containing the Maretron RAA100, you should find the following items.

- 1 - RAA100 Rudder Angle Adapter
- 1 - RAA100 User's Manual
- 1 - Warranty Registration Card

If any of these items are missing or damaged, please contact Maretron.

2.2 Choosing a Mounting Location

The primary function of the RAA100 is to adapt commercially available resistive rudder angle senders to an NMEA 2000[®] network so that rudder angle information can be viewed anywhere on the vessel where there is an NMEA 2000[®] compatible display. The RAA100 can be used together with an analog gauge(s) (referred to as *NMEA 2000[®] / Analog Gauge Mode*), or it can be used standalone to power and sense the resistive sender without an analog gauge(s) (referred to as *NMEA 2000[®] Mode*). If you are using the RAA100 with an analog gauge(s) then refer to Section 2.2.1 for determining an appropriate mounting location and skip Section 2.2.2. If you are using the RAA100 as a standalone adapter without attaching an analog gauge, then skip Section 2.2.1 and refer to Section 2.2.2 for determining an appropriate mounting location.

2.2.1 Mounting Location When Used With Analog Gauge(s)

The RAA100 has two primary connections: 1) the NMEA 2000[®] network connection, and 2) the analog gauge connection. Therefore, the RAA100 should be located between the NMEA 2000[®] trunk line and the analog gauge(s). The reason for choosing this location is because you will be connecting some of the wires within the RAA100's permanently attached gray cable to the gauge and not the actual sender located at the rudder. Maretron recommends placing the RAA100 within 15 feet of the gauge so the RAA100's permanently attached gray cable can be directly connected to the gauge without any splices (see Figure 1). You may also consider placing the RAA100 as close as possible to the NMEA 2000[®] trunk line so you can purchase the shortest or lowest cost NMEA 2000[®] drop cable. In fact, you can connect the RAA100 directly to a tee attached to the NMEA 2000[®] trunk so you don't have to purchase any drop cable. The actual mounting of the RAA100 is not critical and the unit can be mounted in any orientation. The RAA100, NMEA 2000[®] connector, and cable are all waterproof (rated IP67 – protected against temporary immersion in water) so you can mount the unit virtually anywhere. Once you have located a suitable mounting location, you can secure the RAA100 by placing wire ties with screw eyes on the attached cables next to the RAA100.

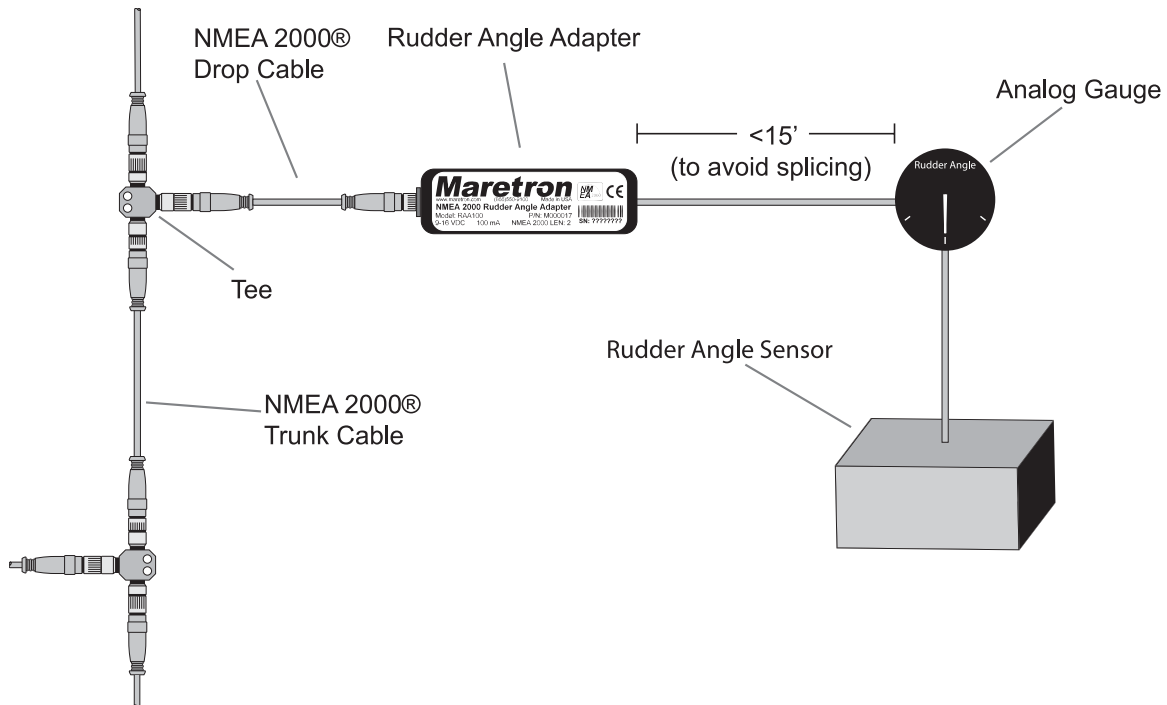

Figure 1– Mounting Location When Used with Analog Gauge

2.2.2 Mounting Location When Used Without Analog Gauge(s)

The RAA100 has two primary connections: 1) the NMEA 2000® network connection, and 2) the resistive rudder angle sender connection. Therefore, the RAA100 should be located between the NMEA 2000® trunk line and the resistive rudder angle sender. The reason for choosing this location is because you will be connecting some of the wires within the RAA100's permanently attached gray cable to the rudder angle sender. Maretron recommends placing the RAA100 within 15 feet of the rudder angle sender so the gray cable can be directly attached to the sender without any splices (see Figure 2). You may also consider placing the RAA100 as close as possible to the NMEA 2000® trunk line so you can purchase the shortest or lowest cost NMEA 2000® drop cable. In fact, you can connect the RAA100 directly to a tee attached to the NMEA 2000® trunk so you don't have to purchase any drop cable. The actual mounting of the RAA100 is not critical and the unit can be mounted in any orientation. The RAA100, NMEA 2000® connector, and cable are all waterproof (rated IP67 – protected against temporary immersion in water) so you can mount the unit virtually anywhere. Once you have located a suitable mounting location, you can secure the RAA100 by placing wire ties with screw eyes on the attached cables near the RAA100.

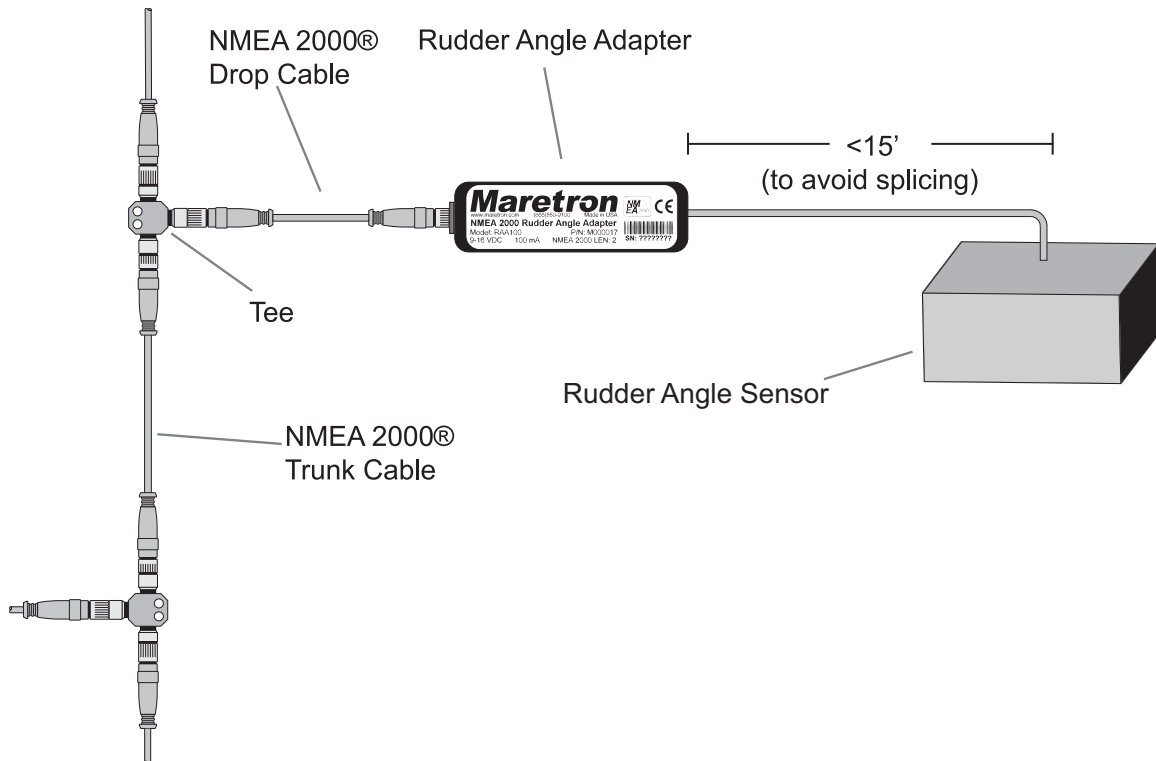

Figure 2 – Mounting Location When Used Without Analog Gauge

2.3 Connecting the RAA100

There are two connection points (see Figure 3) for the RAA100: 1) the permanently attached gray cable for connection to analog gauge or rudder angle sender, and 2) the NMEA 2000[®] connection. Refer to Section 2.3.1 for making the gauge or rudder angle sender connection and Section 2.3.2 for making NMEA 2000[®] connection.



Figure 3 – RAA100 Connections

2.3.1 Connecting Attached Gray Cable to Analog Gauge or Rudder Sender

The RAA100 can be used together with an analog gauge(s) (referred to as *NMEA 2000[®] / Analog Gauge Mode*), or it can be used stand-alone (referred to as *NMEA 2000[®] Mode*) to power and sense the resistive sender without an analog gauge(s). Connecting the RAA100's attached gray cable depends on how the RAA100 will be used. If you are using the RAA100 with an analog gauge(s) then refer to Section 2.3.1.1 and skip Section 2.3.1.2. If you are using

the RAA100 as a stand-alone adapter without attaching an analog gauge, then skip Section 2.3.1.1 and refer to Section 2.3.1.2.

2.3.1.1 Connecting Attached Gray Cable to Analog Gauge

Connecting the RAA100's permanently attached gray cable to the analog gauge does not require the removal of any wires between the gauge and the rudder angle sender. All connections normally made between the gauge and rudder angle sender stay in place and the RAA100 is simply connected to the terminals on the back of the gauge.

Not including the gauge light connections, analog gauges have three connection points or terminals: 1) power, 2) ground, and 3) sensor. The power connection may be marked with a plus sign "+", "+12V", or an "I" or "IGN", while the ground connection is usually marked with a minus sign "-", the earth ground symbol " \perp ", or a "G" for ground, and the sensor connection is generally marked with an "S" for sensor or "G" for gauge. You might have to refer to the gauge documentation or schematic to determine the exact function of the three gauge terminals but it is important to distinguish which terminals are the power, ground, and sensor. Once you have determined the terminals on the back of the gauge, connect the wires found within the RAA100's permanently attached gray cable as shown in Table 1 using recommended wiring practices (i.e., ABYC, Coast Guard, NMEA, ISO, etc.).

Gauge Terminals	Wire Color
Power (+, +12V, I, IGN)	Red
Ground (-, \perp , G)	Black
Sensor (S, G)	Green

Table 1 – RAA100 Gauge Connections

2.3.1.2 Connecting Attached Gray Cable to Rudder Angle Sender

Resistive rudder angle senders have two terminals; 1) the sensor terminal and 2) the ground terminal. The sensor terminal is usually marked with an "S" for sensor or a "G" for gauge where the ground terminal is usually marked with a minus sign "-". A good way to determine which terminal is the ground is to observe which terminal is touching the metal housing; this will be the ground terminal. The sensor terminal will be insulated from the metal housing. Once you have determined the terminals on the resistive rudder angle sender, connect the wires found within the RAA100's permanently attached gray cable as shown in Table 2 using recommended wiring practices (i.e., ABYC, Coast Guard, NMEA, ISO, etc.).

Sender Terminals	Wire Color
Sensor (S, G)	White
Ground (-)	Black

Table 2 – RAA100 Resistive Rudder Angle Sender Connections

2.3.2 Connecting to NMEA 2000® Interface

The Maretron RAA100 provides a connection to an NMEA 2000® interface through a five pin male connector (see Figure 4). You connect the RAA100 to an NMEA 2000® network using a Maretron NMEA 2000® cable (or an NMEA 2000® compatible cable) by connecting the female

end of the cable to the RAA100 (note the key on the male connector and keyway on the female connector). Be sure the cable is connected securely and that the collar on the cable connector is tightened firmly. Connect the other end of the cable (male) to the NMEA 2000[®] network in the same manner. The RAA100 is designed such that you can plug or unplug it from an NMEA 2000[®] network while the power to the network is connected or disconnected. Please follow recommended practices for installing NMEA 2000[®] network products.

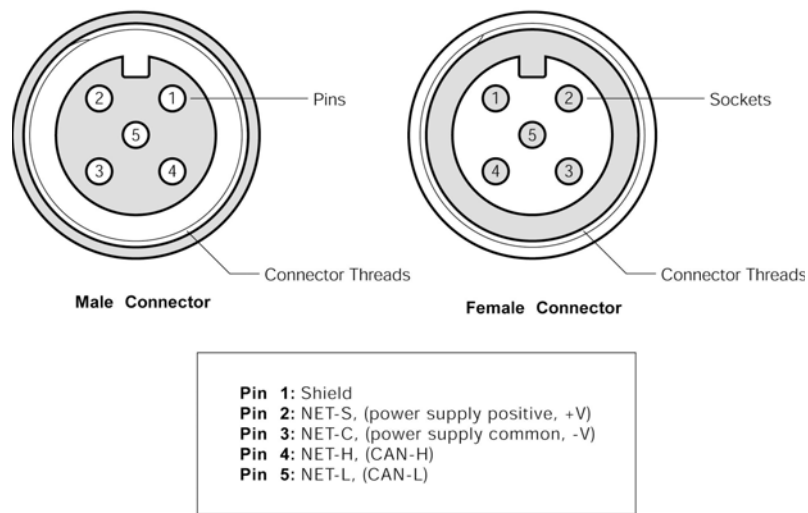

Figure 4 – NMEA 2000[®] Connector Face Views

3 Configuring the RAA100

The RAA100 has several configurable parameters, which are shown below including the default values. If you are not using the default values, then you will need to refer to the corresponding section for configuring the RAA100 appropriately.

1. Rudder Instance Number – Default is Rudder Instance #0 (Section 3.1)
2. Operating Mode – Default is *NMEA 2000[®] Mode* (Section 3.2)
3. Resistive Sender – Default is American standard (Section 3.3)

In addition to configurable parameters, the RAA100 can be calibrated for standard resistive senders (i.e., American standard 240-30 ohm, European standard 10-180 ohms) with maximum rudder angles of 45°, or the RAA100 can be custom calibrated for any sender or maximum rudder angles. Refer to Section 3.3 for choosing a standard type resistive sender or custom calibrating the RAA100.

3.1 Configuring Rudder Instance Number

As shipped from the factory, the RAA100 transmits the Rudder Instance Number as “0”. The NMEA 2000[®] network supports up to 252 rudders (0 through 251). The RAA100 is configured or programmed by choosing a RAA100 rudder instance number using a display product such as the Maretron DSM200. Refer to the user's manual for configuring the RAA100 as the manual provides detailed instruction on configuration procedures.

3.2 Configuring Operating Mode

The RAA100 operates in one of two modes: 1) *NMEA 2000® Mode*, or 2) *NMEA 2000® / Analog Gauge Mode*. You configure or place the RAA100 into *NMEA 2000® Mode* when you are connecting the RAA100 directly to the resistive rudder angle sender (see Figure 2) and you are not using an analog gauge. In *NMEA 2000® Mode*, the RAA100 supplies an electrical current to the resistive rudder angle sender and monitors the changing voltage as the rudder is placed in full port, center, and full starboard positions. Whenever the RAA100 is used together with an analog gauge, then you configure or place the RAA100 into *NMEA 2000® / Analog Gauge Mode*. In this mode, the analog gauge supplies the electrical current to the resistive rudder angle sender while the RAA100 monitors the changing voltage. Placing the RAA100 into *NMEA 2000® / Analog Gauge Mode* requires you to configure or program the RAA100 with the analog gauge's resistance, which is described in Section 3.2.1. You can configure or program a RAA100 operating mode through a display product such as the Maretron DSM200. Refer to the user's manual for configuring the RAA100 as the manual provides detailed instruction on configuration procedures.

3.2.1 Configuring Analog Gauge Resistance

If you are using the RAA100 in the *NMEA 2000® / Analog Gauge Mode*, then two different analog gauge resistances need to be measured and programmed into the RAA100. You will need an ohmmeter to make the two resistive measurements, which are 1) the power terminal to sensor terminal resistance measurement (see Section 3.2.1.1), and 2) the ground terminal to sensor terminal resistance measurement (see Section 3.2.1.2). Once you have made these measurements, you can enter the RAA100 gauge resistances through a display product such as the Maretron DSM200. Refer to the user's manual for configuring the RAA100 as the manual provides detailed instruction on configuration procedures.

3.2.1.1 Power Terminal to Sensor Terminal Resistance Measurement

The first resistance measurement is between the power terminal and the sensor terminal found on the back of the gauge. Before making the measurement, disconnect the power, ground, and sensor wires from the gauge. Then, measure and record the resistance between the power terminal and the sensor terminal (see Section 2.3.1.1 for help in determining which terminal is which). Make sure to adjust the ohmmeter scale to give you whole numbers without over ranging (sometimes indicated by blinking display or a 1 in the far left hand digit position). If you see only numbers right of the decimal point, keep adjusting the scale down (usually the highest ohm scale is indicated by a capital M for mega-ohms or 10^6 ohms while the next lower scale is indicated with a capital K for kilo-ohms or 10^3 ohms). Typical resistance values between the power terminal and the sensor terminal are between 100 and 200 ohms so you should be able to use the 200-ohm scale.

3.2.1.2 Ground Terminal to Sensor Terminal Resistance Measurement

The second resistance measurement is between the ground terminal and the sensor terminal found on the back of the gauge. Before making the measurement, disconnect the power, ground, and sensor wires from the gauge. Then, measure and record the resistance between the ground terminal and the sensor terminal (see Section 2.3.1.1 for help in determining which terminal is which). Typical resistance values between the ground terminal and the sensor

terminal are between 100 and 400 ohms, however, some gauges have very high resistance (i.e., greater than 3000 ohms). A resistance value over 3000 ohms generally indicates a low cost, low accuracy gauge (i.e., gauge reading changes with battery voltage even though the rudder angle is not changing). If the resistance measurement is above 3000 ohms, don't worry about recording the exact reading, as the maximum programmable value in the RAA100 is 3000 ohms. Maretron recommends that you custom calibrate (see Section 3.3.2) your system whenever you are using a gauge with a reading of 3000 ohms or more. Also, you must be aware that these inexpensive gauges won't necessarily agree with the digital data available on the NMEA 2000[®] network as the gauges tend to be inaccurate.

3.3 Standard Sender Selection or Custom Calibration

The RAA100 is capable of accepting standard resistive values with maximum port and starboard rudder angles of 45° (see Section 3.3.1) or it can be calibrated for any resistance range between 0 and 300 or 300 and 0 ohms or other values of maximum rudder angle using the custom calibration procedure (see Section 3.3.2).

3.3.1 Standard Sender Selection

The RAA100 can be used with standard resistive rudder angle senders such as the American Standard (240-30 ohms) or the European Standard (10-180 ohms). This can be a one-step calibration assuming that the maximum port and starboard rudder angles are 45°. You can select which type of sender is attached to the RAA100 using a display product such as the Maretron DSM200. Refer to the user's manual for configuring the RAA100 as the manual provides detailed instruction on configuration procedures.

3.3.2 Custom Calibration

The RAA100 can be custom calibrated for one of several reasons:

1. A non-standard rudder angle sender is being used,
2. The maximum rudder angle (port or starboard) is other than 45°.

Regardless of the reason for custom calibrating the RAA100, you can calibrate the RAA100 using a display product such as the Maretron DSM200. Refer to the user's manual of the particular product that will be used for configuring the RAA100 as these manuals provide detailed instruction on configuration procedures.

4 Maintenance

Regular maintenance is not required, however, an occasional inspection will ensure continued proper operation of the Maretron RAA100. Perform the following tasks periodically:

- Ensure that the unit is mounted securely and cannot be moved relative to the mounting surface. If the unit is loose, tighten the screws holding the cable ties.
- Check the security of the cables connected to the NMEA 2000[®] interface and the connections to the gauge or sender and tighten if necessary.

5 Troubleshooting

If you notice unexpected operation of the Maretron RAA100, follow the troubleshooting procedures in this section to remedy simple problems.

Symptom	Troubleshooting Procedure
No rudder angle output	<ol style="list-style-type: none"> 1. If operating in the <i>NMEA 2000® Mode</i>, check the connections to the NMEA 2000® interface (see Section 2.3.2) and/or the connection to the resistive rudder angle sender (see Section 2.3.1.2) and tighten if necessary. 2. If operating in the <i>NMEA 2000® / Analog Gauge Mode</i>, then check the connections to the NMEA 2000® interface (see Section 2.3.2) and/or the connection to the analog gauge (see Section 2.3.1.1) and tighten if necessary. 3. Ensure that power is supplied to the NMEA 2000® network. Proper network power can be checked by measuring the voltage at an open tee between NET-S and NET-C. The voltage should be between 9 and 16 volts. 4. Ensure that both trunk line terminators are in place. Proper network termination can be checked by removing network power and measuring the resistance at an open tee between NET-L and NET-H signals. The resistance should read approximately 60 ohms (two 120 ohm terminators in parallel equals 60 ohms).
Inaccurate rudder angle output	<ol style="list-style-type: none"> 1. Remember, the accuracy of most analog gauges/resistive rudder angle senders is at best plus or minus 10%. The inaccuracies are due to both the analog gauge and the resistive rudder angle senders. Although the RAA100 is a precision instrument, it is only as good as the resistive sender, which may not be as accurate as you like. Avoid low cost resistive rudder angle senders if you desire good accuracy. 2. If using a standard resistive rudder angle sender (American standard 240-30 ohm, European standard 10-180 ohms), make sure you have correctly configured the RAA100 for the appropriate standard (see Section 3.3.1). If you use the standard setting, the maximum angles for the rudder must be 45°. If the maximum rudder angle is other than 45°. You must use custom calibration. 3. If using a standard resistive rudder angle sender (i.e., American or European), you may want to consider custom calibration (see Section 3.3.2). The standard sensor values assume that you're the rudder is at 45° port and starboard at the end of its travel. Custom calibration will use actual minimum and maximum resistive values and allow you to program the maximum port and starboard angles instead of assuming that the rudder angle is at 45° at the standard resistive extremes. 4. If using custom calibration, re-calibrate the RAA100 (see Section 3.3.2). 5. If operating in the <i>NMEA 2000® / Analog Gauge Mode</i>, ensure correct analog gauge resistive values have been configured or programmed into the RAA100 (see Section 3.2.1)

Figure 5 – Troubleshooting Guide

If these steps do not solve your problem, please contact Maretron Technical Support (refer to Section 7 for contact information).

6 Technical Specifications

Specifications

Parameter	Value	Comment
Accuracy	+/-2%	Does Not Include Inaccuracies of Analog Gauge or Sender
Resolution	+/-1%	Worst Case (Resolution Better at High Resistance Values)
American Standard Senders	240-30 ohms	Standard Sender Types are User Selectable
European Standard Senders	10-180 ohms	Standard Sender Types are User Selectable
Calibration Resistance Range	0-300 ohms	Non-Standard Sender Calibration
Electronic Calibration	Yes	Eliminates need to mechanically adjust or calibrate
Analog Gauge Support	Yes	Can be Used With or Without Analog Gauges

Certifications

Parameter	Comment
NMEA 2000	Level B+
Maritime Navigation and Radiocommunication Equipment & Systems	Tested to IEC 60945
FCC and CE Mark	Electromagnetic Compatibility

NMEA 2000® Parameter Group Numbers (PGNs) - See Appendix A for Details

Description	PGN #	PGN Name	Default Rate
Periodic Data PGNs	127545	Rudder	10 Times/Second
Response to Requested PGNs	126464	PGN List (Transmit and Receive)	N/A
	126996	Product Information	N/A
	126998	Configuration Information	N/A
Protocol PGNs	059392	ISO Acknowledge	N/A
	059904	ISO Request	N/A
	060928	ISO Address Claim	N/A
	065240	ISO Address Command	N/A
	126206	NMEA	N/A

Electrical

Parameter	Value	Comment
Operating Voltage	9 to 16 Volts	DC Voltage
Power Consumption	<100mA	Average Current Drain
Load Equivalence Number (LEN)	2	NMEA 2000® Spec. (1LEN = 50mA)
Reverse Battery Protection	Yes	Indefinitely
Load Dump Protection	Yes	Energy Rated per SAE J1113

Mechanical

Parameter	Value	Comment
Size	3.9" x 1.2" x 1.0"	Excluding NMEA 2000® Connector & Cable
Weight	9 oz.	
Mounting	Any Orientation	

Environmental

Parameter	Value
IEC 60954 Classification	Exposed
Degree of Protection	IP67
Operating Temperature	-25°C to 55°C
Storage Temperature	-40°C to 70°C
Relative Humidity	93%RH @40° per IEC60945-8.2
Vibration	2-13.2Hz @ ±1mm, 13.2-100Hz @ 7m/s2 per IEC 60945-8.7
Rain and Spray	12.5mm Nozzle @ 100liters/min from 3m for 30min per IEC 60945-8.8
Solar Radiation	Ultraviolet B, A, Visible, and Infrared per IEC 60945-8.10
Corrosion (Salt Mist)	4 times 7days @ 40°C, 95%RH after 2 hour Salt Spray Per IEC 60945-8.12
Electromagnet Emission	Conducted and Radiated Emission per IEC 60945-9
Electromagnetic Immunity	Conducted, Radiated, Supply, and ESD per IEC 60945-10
Safety Precautions	Dangerous Voltage, Electromagnetic Radio Frequency per IEC 60945-12

7 Technical Support

If you require technical support for Maretron products, you can reach us in one of the following ways:

Telephone: 1-866-550-9100
Fax: 1-602-861-1777
E-mail: support@maretron.com
World Wide Web: <http://www.maretron.com>
Mail: Maretron, LLC
Attn: Technical Support
9034 N. 23rd Ave Suite 13
Phoenix, AZ 85021 USA

8 Maretron (2 Year) Limited Warranty

Maretron warrants the RAA100 to be free from defects in materials and workmanship for **two (2) years** from the date of original purchase. If within the applicable period any such products shall be proved to Maretron's satisfaction to fail to meet the above limited warranty, such products shall be repaired or replaced at Maretron's option. Purchaser's exclusive remedy and Maretron's sole obligation hereunder, provided product is returned pursuant to the return requirements below, shall be limited to the repair or replacement, at Maretron's option, of any product not meeting the above limited warranty and which is returned to Maretron; or if Maretron is unable to deliver a replacement that is free from defects in materials or workmanship, Purchaser's payment for such product will be refunded. Maretron assumes no liability whatsoever for expenses of removing any defective product or part or for installing the repaired product or part or a replacement therefore or for any loss or damage to equipment in connection with which Maretron's products or parts shall be used. With respect to products not manufactured by Maretron, Maretron's warranty obligation shall in all respects conform to and be limited to the warranty actually extended to Maretron by its supplier. The foregoing warranties shall not apply with respect to products subjected to negligence, misuse, misapplication, accident, damages by circumstances beyond Maretron's control, to improper installation, operation, maintenance, or storage, or to other than normal use or service.

THE FOREGOING WARRANTIES ARE EXPRESSLY IN LIEU OF AND EXCLUDES ALL OTHER EXPRESS OR IMPLIED WARRANTIES, INCLUDING BUT NOT LIMITED TO THE IMPLIED WARRANTIES OF MERCHANTABILITY AND OF FITNESS FOR A PARTICULAR PURPOSE.

Statements made by any person, including representatives of Maretron, which are inconsistent or in conflict with the terms of this Limited Warranty, shall not be binding upon Maretron unless reduced to writing and approved by an officer of Maretron.

IN NO CASE WILL MARETRON BE LIABLE FOR INCIDENTAL OR CONSEQUENTIAL DAMAGES, DAMAGES FOR LOSS OF USE, LOSS OF ANTICIPATED PROFITS OR SAVINGS, OR ANY OTHER LOSS INCURRED BECAUSE OF INTERRUPTION OF SERVICE. IN NO EVENT SHALL MARETRON'S AGGREGATE LIABILITY EXCEED THE PURCHASE PRICE OF THE PRODUCT(S) INVOLVED. MARETRON SHALL NOT BE SUBJECT TO ANY OTHER OBLIGATIONS OR LIABILITIES, WHETHER ARISING OUT OF BREACH OF CONTRACT OR WARRANTY, TORT (INCLUDING NEGLIGENCE), OR OTHER THEORIES OF LAW WITH RESPECT TO PRODUCTS SOLD OR SERVICES RENDERED BY MARETRON, OR ANY UNDERTAKINGS, ACTS OR OMISSIONS RELATING THERETO.

Maretron does not warrant that the functions contained in any software programs or products will meet purchaser's requirements or that the operation of the software programs or products will be uninterrupted or error free. Purchaser assumes responsibility for the selection of the software programs or products to achieve the intended results, and for the installation, use and results obtained from said programs or products. No specifications, samples, descriptions, or illustrations provided Maretron to Purchaser, whether directly, in trade literature, brochures or other documentation shall be construed as warranties of any kind, and any failure to conform with such specifications, samples, descriptions, or illustrations shall not constitute any breach of Maretron's limited warranty.

Warranty Return Procedure:

To apply for warranty claims, contact Maretron or one of its dealers to describe the problem and determine the appropriate course of action. If a return is necessary, place the product in its original packaging together with proof of purchase and send to an Authorized Maretron Service Location. You are responsible for all shipping and insurance charges. Maretron will return the replaced or repaired product with all shipping and handling prepaid except for requests requiring expedited shipping (i.e. overnight shipments). Failure to follow this warranty return procedure could result in the product's warranty becoming null and void.

Maretron reserves the right to modify or replace, at its sole discretion, without prior notification, the warranty listed above. To obtain a copy of the then current warranty policy, please go to the following web page:

<http://www.maretron.com/company/warranty.php>

Appendix A – NMEA 2000® Interfacing

RAA100 NMEA 2000® Periodic Data Transmitted PGNs

PGN 127245 – Rudder

The RAA100 uses this PGN to indicate the attached rudder instance and rudder angle.

- Field 1: Rudder Instance – This field is used to identify the rudder instance number and ranges between 0 and 251.
- 2: Direction Order – This field identifies a directional command contained in this message. The RAA100 ships from the factory with a default value of 0x0 indicating that no direction order is contained in this message.
- 3: Reserved – This field is reserved by NMEA; therefore, the RAA100 sets all bits to a logic 1.
- 4: Angle Order – This field is used to indicate an angle order directed towards a rudder actuator. The RAA100 ships from the factory with a default value of 0x7FFF indicating that no angle order is present in this message.
- 5: Position – This field is used to indicate the current angle of the rudder in units of 0.0001 radians.
- 6: Reserved – This field is reserved by NMEA; therefore, the RAA100 sets all bits to a logic 1.