

OWNER'S GUIDE & INSTALLATION INSTRUCTIONS

Thru-Hull, Retractable *with* Valve Speed & Temperature Sensor

Model ST800

Record the information found on the cable tag for future reference.

Part No. _____ Date _____

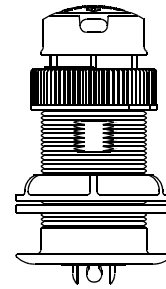

plastic
low profile
P120 housing

Follow the precautions below for optimal product performance and to reduce the risk of property damage, personal injury, and death.

WARNING: Always wear safety goggles, a dust mask, and ear plugs when installing.

WARNING: The valve is not a watertight seal! Always use the insert or blanking plug secured with the safety wire for a watertight seal.

WARNING: The O-rings must be intact and well lubricated to make a watertight seal.

WARNING: Always attach the safety wire to prevent the insert or blanking plug from backing out in the unlikely event that the cap nut fails or is screwed on incorrectly.

WARNING: Immediately check for leaks when the boat is placed in the water. Do not leave the boat unchecked for more than three hours. Even a small leak may allow considerable water to accumulate.

CAUTION: Plastic housing—Never use a fairing with a plastic housing. The protruding sensor would be vulnerable to damage from impact.

CAUTION: Bronze housing—Never install a metal housing on a vessel with a positive ground system.

CAUTION: Never pull, carry, or hold the sensor by its cable. This may sever internal connections.

CAUTION: The arrow on the top of the insert must point forward toward the bow to align the paddlewheel with the water flow.

CAUTION: Never use solvents. Cleaners, fuel, sealant, paint, and other products may contain solvents that can damage plastic parts.

IMPORTANT: Please read the instructions completely before proceeding with the installation. These instructions supersede any other instructions in your instrument manual if they differ.

Applications

- **Plastic** housing recommended for fiberglass or metal hull only. *Never install a plastic housing in a wood hull because swelling of the wood can possibly fracture the plastic.*
- **Bronze** housing recommended for fiberglass or wood hull. *Never mount a bronze housing in an aluminum hull because electrolytic corrosion will occur.*

Pretest

Connect the sensor to the instrument and spin the paddlewheel. Check for a speed reading and the approximate air temperature. If there are no readings or they are inaccurate, check all the connections and try again. If there is still a problem, return the product to the place of purchase.

Tools & Materials

Safety goggles
Dust mask
Ear plugs
Water-based anti-fouling paint (**mandatory in salt water**)
Electric drill with 10 mm (3/8") or larger chuck capacity
Drill bit: 3 mm or 1/8"
Hole saw: 51 mm or 2"
Sandpaper
Mild household detergent or weak solvent (such as alcohol)
File (installation in a metal hull)
Marine sealant (suitable for below waterline)
Additional washer [for aluminum hull less than 6 mm (1/4") thick]
Slip-joint pliers (installing a bronze housing)
Grommet(s) (some installations)
Cable ties
Installation in a cored fiberglass hull (see page 3):
Hole saw for hull interior: 60 mm or 2-3/8"
Fiberglass cloth and resin
or Cylinder, wax, tape, and casting epoxy

Mounting Location

Turbulence-free water must flow over the paddlewheel at all boat speeds. Choose an accessible spot inside the vessel. Allow a minimum of 280 mm (11") of space for the height of the housing, tightening the nuts, and removing the insert.

CAUTION: Do not mount the sensor directly ahead of a depth transducer, because turbulence generated by the paddlewheel's rotation will adversely affect the depth transducer's performance, especially at high speeds. Mount side by side.

CAUTION: Do not mount the sensor in line with or near water intake or discharge openings; behind strakes, fittings, or hull irregularities that will disturb the water flow.

- **Displacement hull powerboats**—Locate amidships near the centerline.
- **Planing hull powerboats**—Mount well aft to ensure the sensor is in contact with the water at high speeds.
- **Fin keel sailboats**—Mount on or near the centerline and forward of the fin keel 300–600mm (1–2').
- **Full keel sailboats**—Locate amidships and away from the keel at the point of minimum deadrise.

Anti-fouling Paint

Surfaces exposed to salt water must be coated with anti-fouling paint. Use water-based anti-fouling paint only. Never use ketone-based paint, because ketones can attack many plastics possibly damaging the sensor.

It is easier to apply anti-fouling paint before installation, but allow sufficient drying time. Reapply paint every 6 months or at the beginning of each boating season. Paint the following surfaces (see Figure 1):

- Outside wall of the insert below the lower O-ring
- Paddlewheel
- Paddlewheel cavity
- Bore of the housing up 30 mm (1-1/4")
- Exterior flange of the housing
- Blanking plug below the lower O-ring including the exposed end

Installation

Hole Drilling

Cored fiberglass hull—Follow separate instructions on page 3.

1. Drill a 3mm or 1/8" pilot hole from inside the hull. If there is a rib, strut, or other hull irregularity near the selected mounting location, drill from the outside.
2. Using a 51 mm or 2" hole saw, cut a hole perpendicular to the hull from outside the boat.
3. Sand and clean the area around the hole, inside and outside, to ensure that the marine sealant will adhere properly to the hull. If there is any petroleum residue inside the hull, remove it with

either mild household detergent or a weak solvent (alcohol) before sanding.

Metal hull—Remove all burrs with a file and sandpaper.

Bedding

CAUTION: Be sure the surfaces to be bedded are clean and dry.

Apply a 2mm (1/16") thick layer of marine sealant around the flange of the housing that will contact the hull and up the sidewall of the housing (see Figure 2). *The sealant must extend 6mm (1/4") higher than the combined thickness of the hull, washer(s), and hull nut.* This will ensure there is marine sealant in the threads to seal the hull and hold the hull nut securely in place.

Installing

1. From outside the hull, push the housing into the mounting hole using a twisting motion to squeeze out excess marine sealant (see Figure 2). *Align the arrow on the flange of the housing to point forward toward the bow.* If the sensor is not installed on the centerline, angle the housing slightly toward the centerline to align it with the water flow.

2. From inside the hull, slide the washer onto the housing.

Aluminum hull less than 6mm (1/4") thick—Use an additional rubbery, fiberglass, or plastic washer. Never use bronze because electrolytic corrosion will occur. Never use wood because it will swell, possibly fracturing the plastic housing.

3. Screw the hull nut in place being sure the notch on the upper rim of the housing and the corresponding arrow on the flange are still positioned forward toward the bow.

Plastic housing—Do not clamp tightly on the wrenching flats, possibly causing the housing to fracture.

Plastic hull nut—Hand tighten only. Do not over tighten.

Bronze hull nut—Tighten with slip-joint pliers.

Cored fiberglass hull—Do not over tighten, crushing the hull.

Wood hull—Allow the wood to swell before tightening the nut.

4. Remove any excess marine sealant on the outside of the hull to ensure smooth water flow under the sensor.

5. The O-rings must be intact and well lubricated to make a watertight seal. After the marine sealant cures, inspect the O-rings on the insert (replace if necessary) and lubricate them with the silicone lubricant supplied.

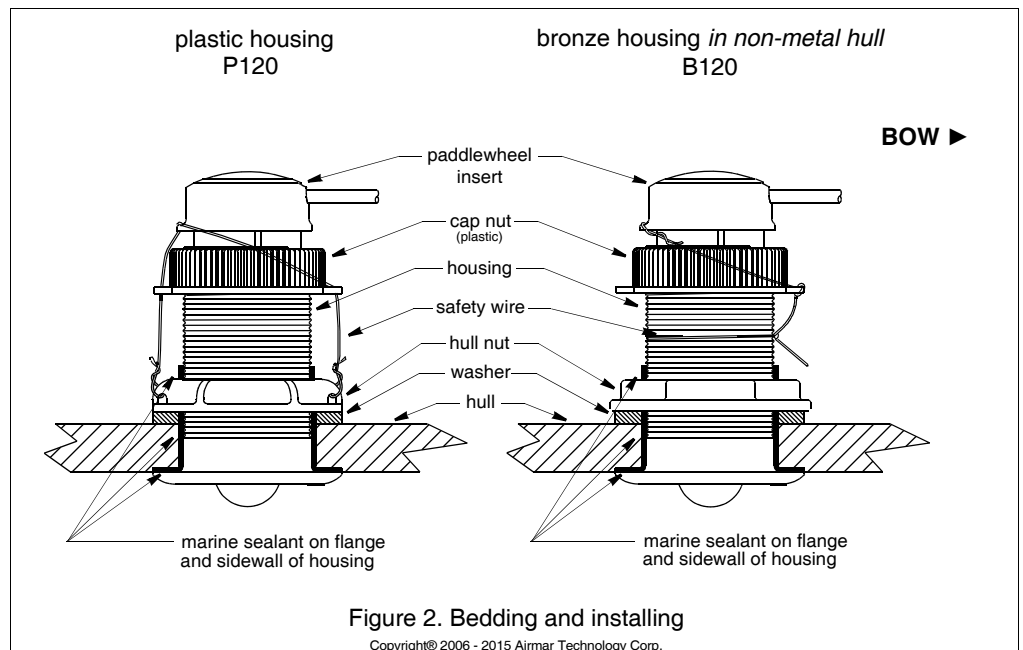
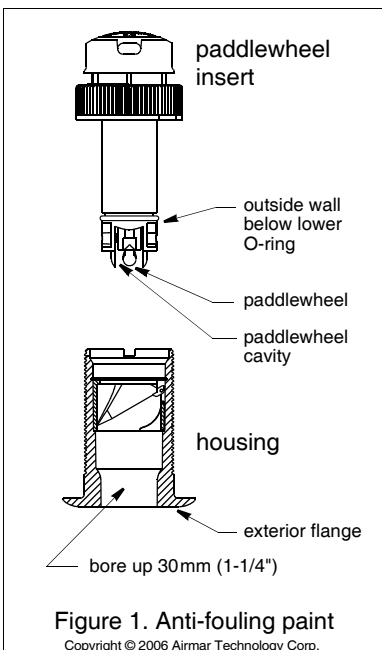

6. Slide the insert into the housing with the arrow on the top pointing forward toward the bow. Screw the cap nut several turns until the threads are engaged. *Rotate the insert until the key fits into the notch in the housing.* The arrow on the top of the insert, the cable exit, the notch in the housing, and the arrow on the flange will all be aligned. Continue to tighten the cap nut. Be careful not to rotate the housing and disturb the sealant. **Hand tighten** only. Do not over tighten.

7. Always attach the safety wire to prevent the insert from backing out in the unlikely event that the cap nut fails or is screwed on incorrectly.

Plastic housing—Attach the safety wire to one eye in the hull nut. Keeping the wire taut throughout, lead the wire in a counter-clockwise direction. Thread it through one eye in the cap nut, the eye in the insert, the second eye in the cap nut, and the second eye in the hull nut. Twist the wire securely to itself.

Bronze housing—Wrap one end of the safety wire tightly around the housing and twist it together with the long end. Keeping the wire taut throughout, lead the wire straight up and through one eye in the cap nut. Thread the wire through the eye a second time. Lead the wire counterclockwise and through the eye in the insert. Twist the wire securely to itself.

Cable Routing & Connecting

CAUTION: If your sensor came with a connector, do not remove it to ease cable routing. If the cable must be cut and spliced, use Airmar's splash-proof Junction Box No. 33-035 and follow the instructions provided. Removing the waterproof connector or cutting the cable, except when using a watertight junction box, will void the sensor's warranty.

1. Route the cable to the instrument being careful not to tear the cable jacket when passing it through the bulkhead(s) and other parts of the boat. Use grommets to prevent chafing. To reduce electrical interference, separate the sensor cable from other electrical wiring and the engine. Coil any excess cable and secure it in place with cable-ties to prevent damage.
2. Refer to the instrument owner's manual to connect the sensor to the instrument.

Checking for Leaks

When the boat is placed in the water, **immediately** check around the sensor for leaks. Note that very small leaks may not be readily observed. *Do not leave the boat in the water for more than 3 hours before checking it again.* If there is a small leak, there may be considerable bilge water accumulation after 24 hours. If a leak is observed, repeat "Bedding" **immediately** (see page 2).

Installation in a Cored Fiberglass Hull

The core (wood or foam) must be cut and sealed carefully. The core must be protected from water seepage, and the hull must be reinforced to prevent it from crushing under the hull nut allowing the housing to become loose.

CAUTION: Completely seal the hull to prevent water seepage into the core.

1. Drill a 3mm or 1/8" pilot hole from inside the hull. If there is a rib, strut, or other hull irregularity near the selected mounting location, drill from the outside. (If the hole is drilled in the wrong location, drill a second hole in a better location. Apply masking tape to the outside of the hull over the incorrect hole and fill it with epoxy.)

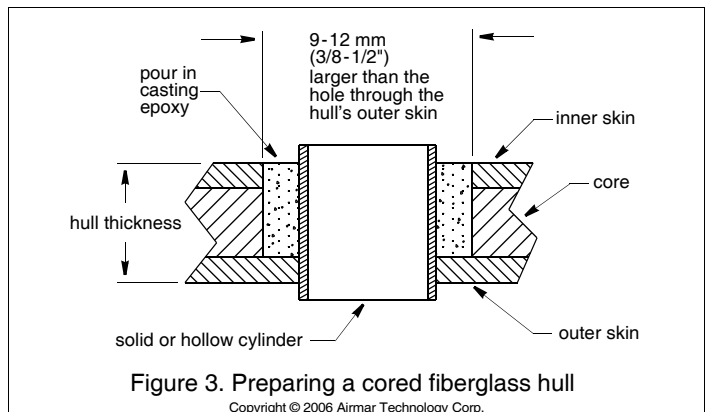

2. Using a 51 mm or 2" hole saw, cut the hole from outside the hull through the *outer skin* only (see Figure 3).
3. From inside the hull, use a 60mm or 2-3/8" hole saw to cut through the *inner skin* and most of the core. The core material can be very soft. Apply only light pressure to the hole saw after cutting through the inner skin to avoid accidentally cutting the *outer skin*.
4. Remove the plug of core material so the *inside* of the outer skin and the inner core of the hull are fully exposed. Sand and clean the inner skin, core, and the outer skin around the hole.
5. If you are skilled with fiberglass, saturate a layer of fiberglass cloth with a suitable resin and lay it inside the hole to seal and strengthen the core. Add layers until the hole is the correct diameter.

Alternatively, a hollow or solid cylinder of the correct diameter can be coated with wax and taped in place. Fill the gap between the cylinder and hull with casting epoxy. After the epoxy has set, remove the cylinder.
6. Sand and clean the area around the hole, inside and outside, to ensure that the marine sealant will adhere properly to the hull. If there is any petroleum residue inside the hull, remove it with either mild household detergent or a weak solvent (alcohol) before sanding.
7. Proceed with "Bedding" and "Installing" (see page 2).

Operation & Maintenance

How the Valve Works

The valve is not a watertight seal! The sensor incorporates a self-closing valve which minimizes the flow of water into the vessel when the insert is removed. The curved flap valve is activated by both a spring and water pressure. Water pushes the flap valve upward to block the opening, so there is no gush of water into the boat. *Always install the insert or the blanking plug secured with the cap nut and safety wire for a watertight seal.*

Using the Blanking Plug

To protect the paddlewheel insert, use the blanking plug:

- When the boat will be kept in salt water for more than a week.
- When the boat will be removed from the water.
- When aquatic growth buildup is suspected due to inaccurate readings from the instrument.

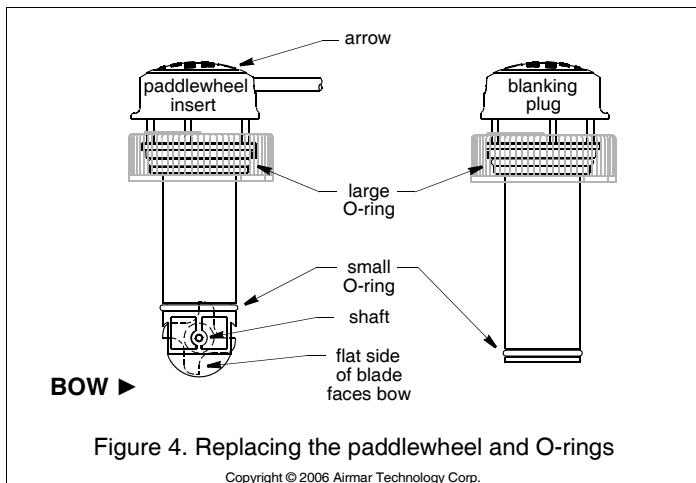

Figure 4. Replacing the paddlewheel and O-rings

1. The O-rings must be intact and well lubricated to make a watertight seal. On the blanking plug, inspect the O-rings (replace if necessary) and lubricate them with the silicone lubricant supplied or petroleum jelly (Vaseline®) (see Figure 4).
2. Remove the insert from the housing by removing the safety wire from the cap nut. Unscrew the cap nut to lift the insert (see Figure 2). Remove the insert with a slow pulling motion.
3. Slide the blanking plug into the housing. Screw the cap nut several turns until the threads are engaged. *Rotate the blanking plug until the key fits into the notch in the housing.* Continue to tighten the cap nut. **Hand tighten** only. Do not over tighten.
4. Reattach the safety wire to prevent the blanking plug from backing out in the unlikely event that the cap nut fails or is screwed on incorrectly.

Winterizing

After the boat has been hauled for winter storage, remove the blanking plug to let the water drain away before reinserting it. This will prevent any water from freezing around the blanking plug and possibly cracking it.

Servicing the Insert

Aquatic growth can impede or freeze the paddlewheel's rotation and must be removed. Clean the surface using a Scotch-Brite® scour pad and mild household detergent. If fouling is severe, push out the shaft using a spare shaft or a 4D finish nail with a flattened point. Then, lightly wet sand the surface with fine grade wet/dry paper.

The water lubricated paddlewheel bearings have a life of up to 5 years on low-speed boats [less than 10kn (11 MPH)] and 1 year on high-speed vessels. Paddlewheels can fracture and shafts can bend due to impact with water borne objects. O-rings must be free of abrasions and cuts to ensure a watertight seal. Order a replacement Paddlewheel, Shaft & O-ring Kit, 33-499-01.

1. Using the new shaft, push the old shaft out about 6mm (1/4"). With pliers, remove the old shaft (see Figure 4).
2. Place the new paddlewheel in the cavity with the flat side of the blade facing the same direction as the arrow on the insert top.
3. Tap the new shaft into place until the ends are flush with the insert.
4. Install a *large* O-ring near the top and a *small* O-ring near the paddlewheel.
5. Place the two remaining O-rings in similar positions on the blanking plug.

Servicing the Valve Assembly

Should the valve fail, remove it for servicing.

1. The O-rings must be intact and well lubricated to make a watertight seal. On the blanking plug, inspect the O-rings (replace if necessary) and lubricate them with silicone lubricant or petroleum jelly (Vaseline®).
2. Remove the insert/blanking plug from the housing.
3. Remove the snap ring from the valve assembly using a screw-driver to pry the end of the ring free (see Figure 5).
4. Slide the valve assembly upward and out of the housing slowly.

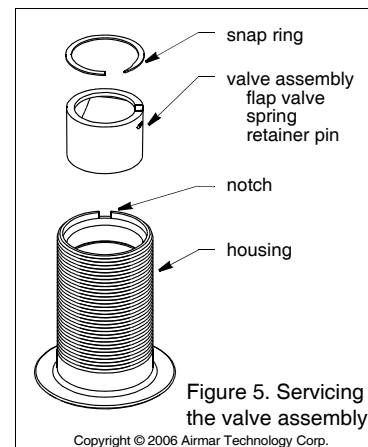

Figure 5. Servicing the valve assembly

- NOTE:** The flap valve retainer pin is a loose slip-fit and may fall out when the assembly is removed.
5. Push the blanking plug into the housing. Screw the cap nut several turns until the threads are engaged. *Rotate the blanking plug until the key fits into the notch in the housing.* Continue to tighten the cap nut. **Hand tighten** only. Do not over tighten. Reattach the safety wire (see Figure 2).
 6. Clean, repair, or replace the valve assembly so the flap valve moves freely and seats against the valve housing.
 7. To reinstall the valve assembly, first reassemble the flap valve in the valve housing with the retainer pin and spring in place (see Figure 5).
 8. Remove the blanking plug. Slide the valve assembly into the housing with the flap valve pointing downward. *Install the snap ring being certain that it LOCKS INTO THE GROOVE in the housing wall.*
 9. Slide the insert (or the blanking plug) into the housing with the arrow on the top pointing forward toward the bow. Screw the cap nut several turns until the threads are engaged. *Rotate the insert (or the blanking plug) until the key engages the notch in the housing.* Be sure the arrow on the top is facing forward toward the bow. Continue to tighten the cap nut. **Hand tighten** only. Do not over tighten.
 10. Reattach the safety wire to prevent the insert/blanking plug from backing out in the unlikely event that the cap nut fails or is screwed on incorrectly (see Figure 2).

Replacement Sensor & Parts

The information needed to order a replacement sensor is printed on the cable tag. Do not remove this tag. When ordering, specify the part number and date. For convenient reference, record this information on the top of page one.

Lost, broken, and worn parts should be replaced immediately. If you have purchased a plastic housing and have a wood hull or desire greater strength, purchase a bronze housing.

Blanking Plug	Hull Nut	Housing, Hull Nut & Washer	Paddlewheel & Valve Kit
33-481-01	04-004 (plastic) 02-030 (bronze)	33-340-02 (plastic, P120) 33-340-01 (bronze, B120)	33-493-01

Paddlewheel, Shaft & O-ring Kit 33-499-01

Obtain parts from your instrument manufacturer or marine dealer.

Gemeco (USA)

Tel: 803.693.0777

Fax: 803.693.0477

email: sales@gemeco.com

Airmar EMEA

Tel: +33.(0)2.23.52.06.48

(Europe, Middle East, Africa)

Fax: +33.(0)2.23.52.06.49

email: sales@airmar-emea.com



35 Meadowbrook Drive, Milford, New Hampshire 03055-4613, USA

• www.airmar.com

Copyright © 2004 - 2015 Airmar Technology Corp. All rights reserved.